

# SECTION 9: PARTS

## Headstock

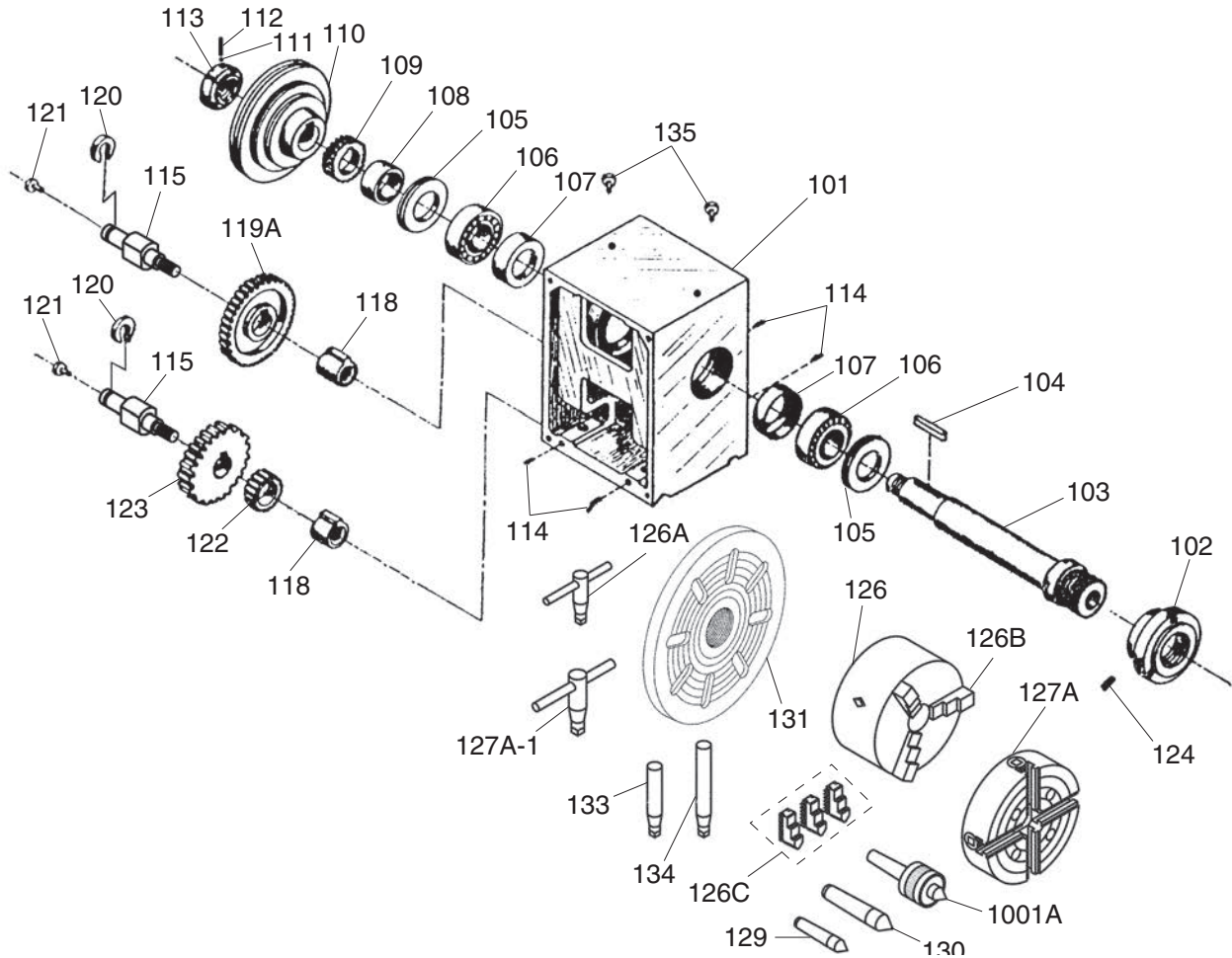

REF	PART #	DESCRIPTION
101	P4000101	HEADSTOCK CASTING
102	P4000102	3-JAW CHUCK BACK PLATE
103	P4000103	SPINDLE
104	P4000104	SPINDLE SHAFT KEY
105	P4000105	GASKET
106	P4000106	TAPERED BEARING 32007
107	P4000107	BEARING CAP
108	P4000108	SPACER
109	P4000109	GEAR 40T X 30MM
110	P4000110	SPINDLE PULLEY
111	P4000111	STEEL BALL
112	P4000112	SET SCREW M4-.7 X 5
113	P4000113	THREADED LOCK COLLAR
114	P4000114	SET SCREW M4-.7 X 10
115	P4000115	SHAFT
118	P4000118	KEYED BUSHING
119A	P4000119A	GEAR 80T METAL
120	P4000120	RETAINING CLIP

REF	PART #	DESCRIPTION
121	P4000121	OIL PORT 6MM
122	P4000122	GEAR 40T X 14MM
123	P4000123	GEAR 28T
124	P4000124	SET SCREW M6-1 X 10
126	P4000126	3-JAW CHUCK 4"
126A	P4000126A	3-JAW CHUCK KEY
126B	P4000126B	3-JAW REVERSE JAWS 3PC SET
126C	P4000126C	3-JAW INTERNAL 3-PC JAWS V2.03.07
127A	P4000127A	4-JAW CHUCK 7-1/4"
127A-1	P4000127A-1	4-JAW CHUCK KEY
129	P4000129	DEAD CENTER MT#2
130	P4000130	DEAD CENTER MT#3
131	P4000131	FACEPLATE 7-1/2"
133	P4000133	CHUCK BAR SHORT
134	P4000134	CHUCK BAR LONG
135	P4000135	BALL OILER 8MM PRESS-IN
1001A	P40001001A	LIVE CENTER MT#2



# Drive Belt

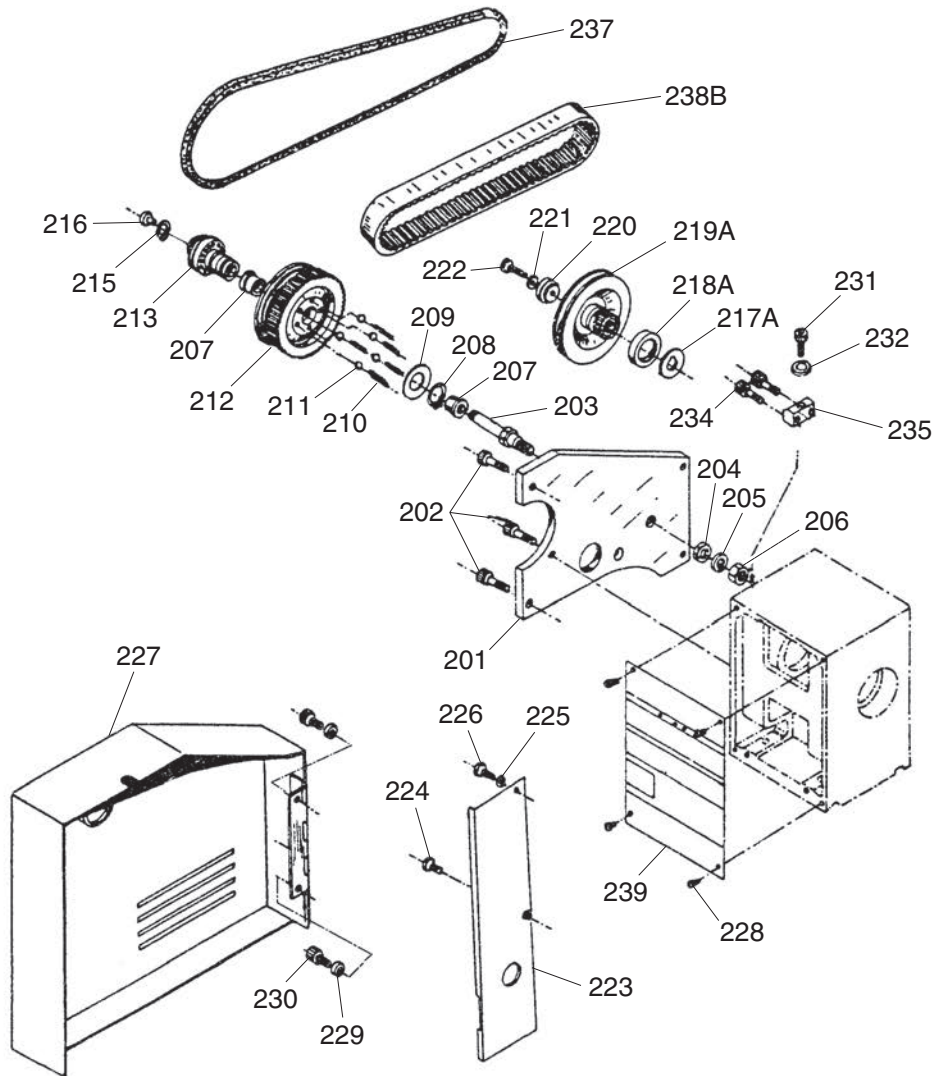

REF	PART #	DESCRIPTION
201	P4000201	BRACKET PLATE
202	P4000202	CAP SCREW M5-.8 X 20
203	P4000203	IDLER PULLEY SHAFT
204	P4000204	FLAT WASHER 10MM
205	P4000205	LOCK WASHER 10MM
206	P4000206	HEX NUT M10-1.5
207	P4000207	BUSHING
208	P4000208	EXT RETAINING RING 25MM
209	P4000209	IDLER PULLEY WASHER
210	P4000210	COMPRESSION SPRING
211	P4000211	STEEL BALL
212	P4000212	IDLER PULLEY
213	P4000213	CLUTCH HUB
215	P4000215	EXT RETAINING RING 12MM
216	P4000216	OIL PORT
217A	P4000217A	SPACER - CHINA MOTOR
218A	P4000218A	COLLAR - CHINA MOTOR
219A	P4000219A	MOTOR PULLEY - CHINA MOTOR

REF	PART #	DESCRIPTION
220	P4000220	MOTOR PULLEY WASHER
221	P4000221	LOCK WASHER 6MM
222	P4000222	CAP SCREW M6-1 X 25
223	P4000223	COVER PLATE
224	P4000224	CAP SCREW M5-.8 X 12
225	P4000225	FLAT WASHER 5MM
226	P4000226	CAP SCREW M5-.8 X 8
227	P4000227	CHANGE GEAR COVER W/HINGE
228	P4000228	CAP SCREW M4-.7 X 10
229	P4000229	FLAT WASHER 6MM
230	P4000230	CAP SCREW M6-1 X 10
231	P4000231	CAP SCREW M6-1 X 25
232	P4000232	FLAT WASHER 6MM
234	P4000234	CAP SCREW M6-1 X 20
235	P4000235	CLAMP BLOCK
237	P4000237	V-BELT 5 X 710MM
238B	P4000238B	TOOTH BELT 170 X L050 CHINA
239	P4000239	CONFIGURATION PLATE



# Belt Tension Lever

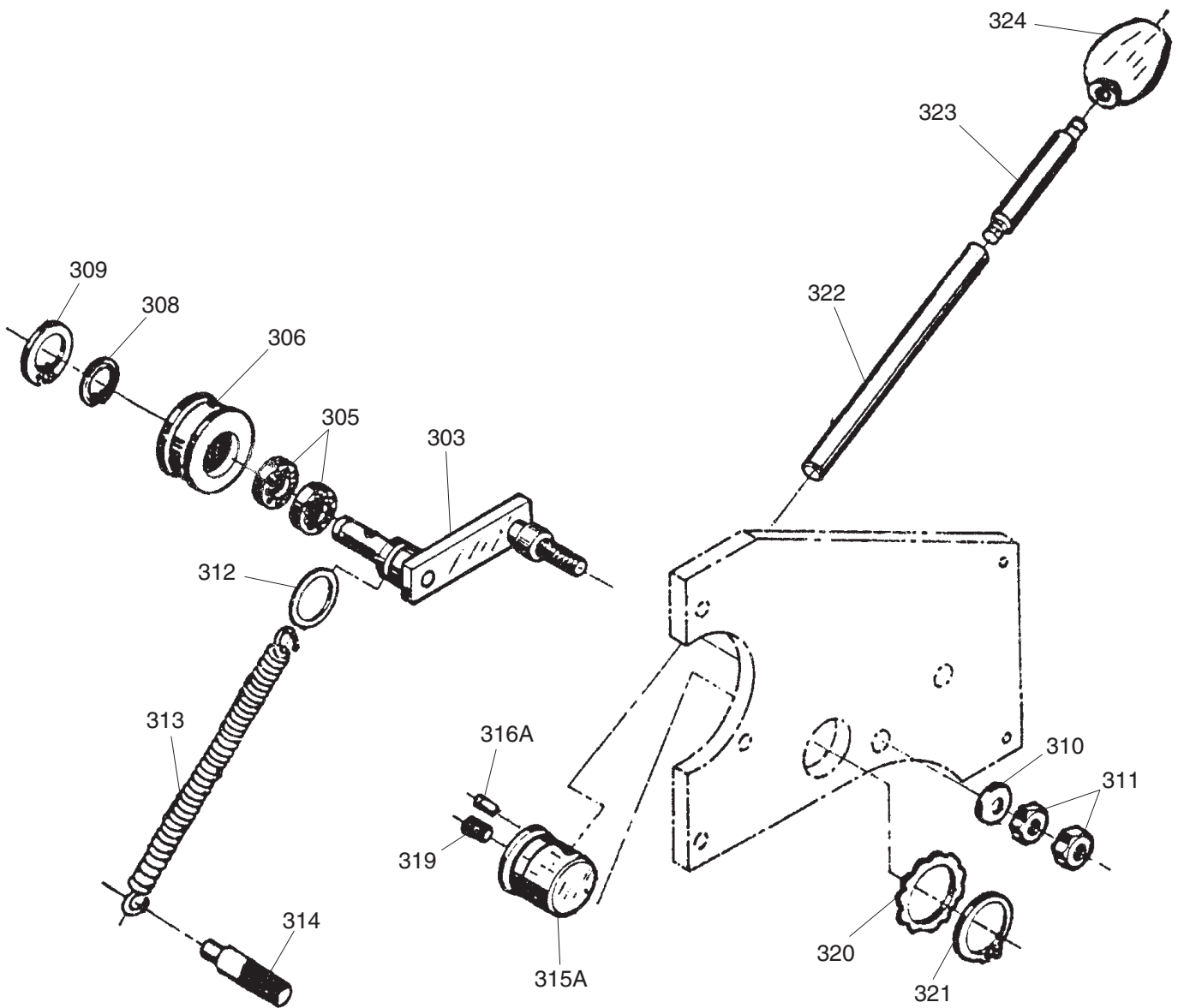

REF	PART #	DESCRIPTION
303	P4000303	LEVER BRACKET ASSEMBLY
305	P4000305	BALL BEARING 6001ZZ
306	P4000306	ROLLER
308	P4000308	EXT RETAINING RING 12MM
309	P4000309	INT RETAINING RING 28MM
310	P4000310	FLAT WASHER 10MM
311	P4000311	HEX NUT M10-1.5
312	P4000312	SPRING RING
313	P4000313	TENSION SPRING

REF	PART #	DESCRIPTION
314	P4000314	STUD BOLT
315A	P4000315A	TENSIONING CAM V2.08.07
316A	P4000316A	CAP SCREW M6-1 X 25
319	P4000319	SET SCREW M8-1.25 X 8
320	P4000320	WAVY WASHER
321	P4000321	EXT RETAINING RING 34MM
322	P4000322	BELT TENSION LEVER
323	P4000323	EXTENSION ROD
324	P4000324	KNOB



# Change Gears

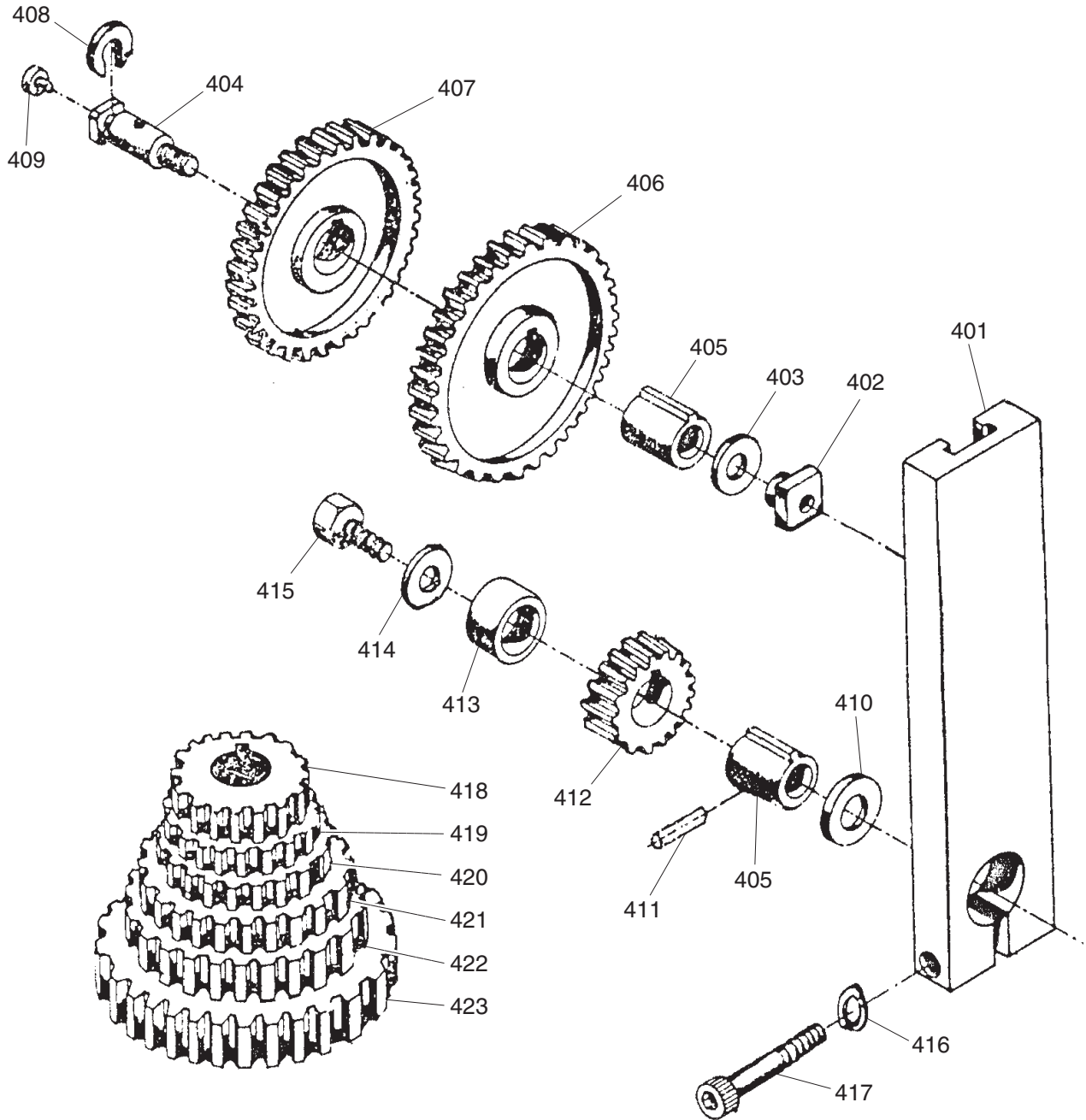

REF	PART #	DESCRIPTION
401	P4000401	BRACKET
402	P4000402	T-NUT M6-1
403	P4000403	FLAT WASHER 6MM
404	P4000404	SHAFT
405	P4000405	KEYED BUSHING
406	P4000406	GEAR 127T
407	P4000407	GEAR 120T
408	P4000408	SHAFT RETAINING CLIP
409	P4000409	OIL PORT 6MM
410	P4000410	FLAT WASHER 10MM
411	P4000411	ROLL PIN 4 X 14
412	P4000412	GEAR 30T

REF	PART #	DESCRIPTION
413	P4000413	SPACER
414	P4000414	FLAT WASHER 6MM
415	P4000415	CAP SCREW M6-1 X 10
416	P4000416	LOCK WASHER 6MM
417	P4000417	CAP SCREW M6-1 X 35
418	P4000418	GEAR 28T
419	P4000419	GEAR 36T
420	P4000420	GEAR 42T
421	P4000421	GEAR 45T
422	P4000422	GEAR 60T
423	P4000423	GEAR 80T



# Electrical & Tools

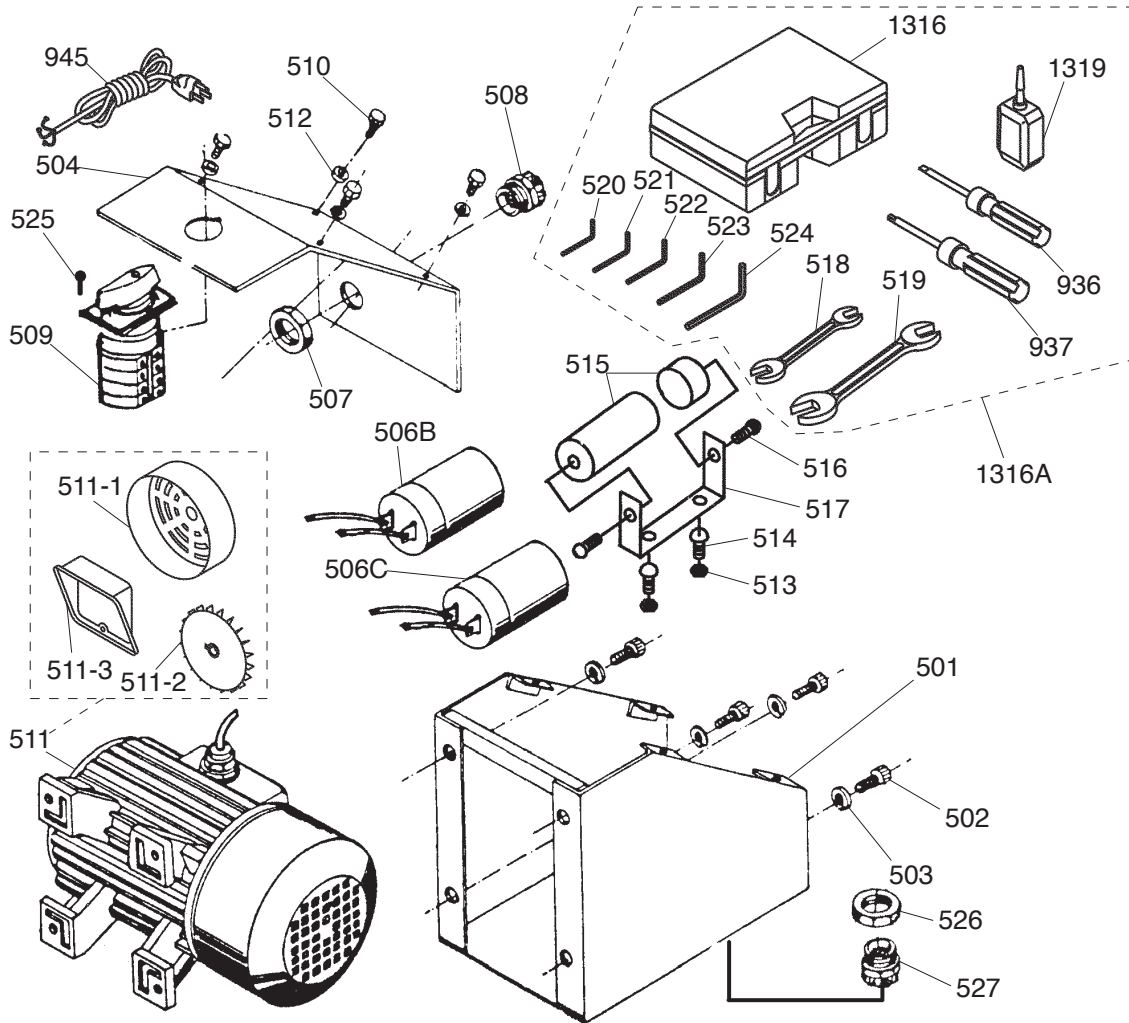

REF	PART #	DESCRIPTION
501	P4000501	ELECTRICAL BOX
502	P4000502	CAP SCREW M5-.8 X 10
503	P4000503	LOCK WASHER 6MM
504	P4000504	ELECTRICAL BOX COVER
506B	P4000506B	R CAPACITOR 20M 400V 1-5/8 X 2-7/8
506C	P4000506C	S CAPACITOR 100M 250V 1-5/8 X 3-1/8
507	P4000507	STRAIN RELIEF NUT M16-1
508	P4000508	STRAIN RELIEF M16
509	P4000509	SPINDLE SWITCH
510	P4000510	PHLP HD SCR M5-.8 X 10
511	P4000511	MOTOR 3/4HP 110V 60HZ
511-1	P4000511-1	MOTOR FAN COVER
511-2	P4000511-2	MOTOR FAN
511-3	P4000511-3	TERMINAL COVER
512	P4000512	LOCK WASHER 5MM
513	P4000513	HEX NUT M4-.7
514	P4000514	PHLP HD SCR M4-.7 X 8
515	P4000515	CAPACITOR COVER W/CAP

REF	PART #	DESCRIPTION
516	P4000516	PHLP HD SCR M4-.7 X 6
517	P4000517	CAPACITOR CLIP
518	P4000518	WRENCH 8/10MM
519	P4000519	WRENCH 12/14MM
520	P4000520	HEX WRENCH 1.5MM
521	P4000521	HEX WRENCH 2MM
522	P4000522	HEX WRENCH 4MM
523	P4000523	HEX WRENCH 5MM
524	P4000524	HEX WRENCH 6MM
525	P4000525	PHLP HD SCR M4-.7 X 16
526	P4000526	STRAIN RELIEF NUT M24-1.5
527	P4000527	STRAIN RELIEF M24
936	P4000936	SCREWDRIVER FLAT #2
937	P4000937	SCREWDRIVER PHILLIPS #2
945	P4000945	POWER CORD 16/3/110V
1316	P40001316	TOOL BOX
1316A	P40001316A	COMPLETE TOOL BOX
1319	P40001319	OIL BOTTLE



# Quick Change Gears

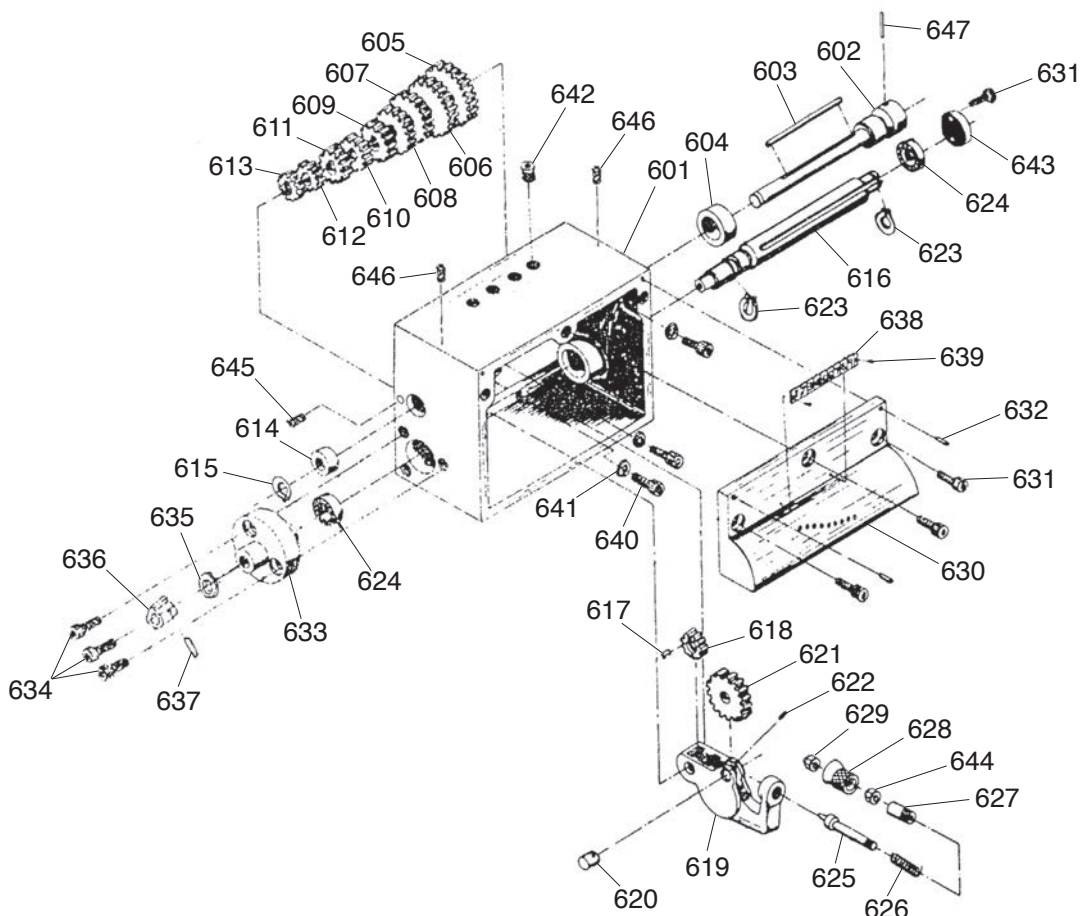

REF	PART #	DESCRIPTION
601	P4000601	GEARBOX CASTING
602	P4000602	SHAFT
603	P4000603	KEY 5 X 5 X 70
604	P4000604	BUSHING
605	P4000605	GEAR 28T
606	P4000606	GEAR 26T
607	P4000607	GEAR 24T
608	P4000608	GEAR 23T
609	P4000609	GEAR 22T
610	P4000610	GEAR 20T
611	P4000611	GEAR 19T
612	P4000612	GEAR 18T
613	P4000613	GEAR 16T
614	P4000614	BUSHING
615	P4000615	EXT RETAINING RING 16MM
616	P4000616	SHAFT
617	P4000617	KEY 5 X 5 X 12
618	P4000618	GEAR 16T
619	P4000619	SHIFT ARM
620	P4000620	SHAFT
621	P4000621	GEAR 36T
622	P4000622	SET SCREW M5-.8 X 10
623	P4000623	EXT RETAINING RING 15MM
624	P4000624	BALL BEARING 6202ZZ

REF	PART #	DESCRIPTION
625	P4000625	PLUNGER
626	P4000626	COMPRESSION SPRING
627	P4000627	BUSHING
628	P4000628	KNURLED KNOB
629	P4000629	ACORN NUT M6-1
630	P4000630	GEARBOX FRONT COVER
631	P4000631	CAP SCREW M6-1 X 16
632	P4000632	ROLL PIN 4 X 22
633	P4000633	BRACKET
634	P4000634	CAP SCREW M6-1 X 10
635	P4000635	FLAT WASHER 10MM
636	P4000636	BUSHING
637	P4000637	ROLL PIN 4 X 14
638	P4000638	NUMBER PLATE
639	P4000639	COPPER FLUTED RIVET 2 X 5MM
640	P4000640	CAP SCREW M8-1.25 X 20
641	P4000641	LOCK WASHER 8MM
642	P4000642	OIL CUP
643	P4000643	BEARING CAP
644	P4000644	HEX NUT M6-1
645	P4000645	SET SCREW M4-.7 X 16
646	P4000646	TAP-IN BALL OILER 6MM
647	P4000647	ROLL PIN 4 X 12



# Apron Breakdown

Front View

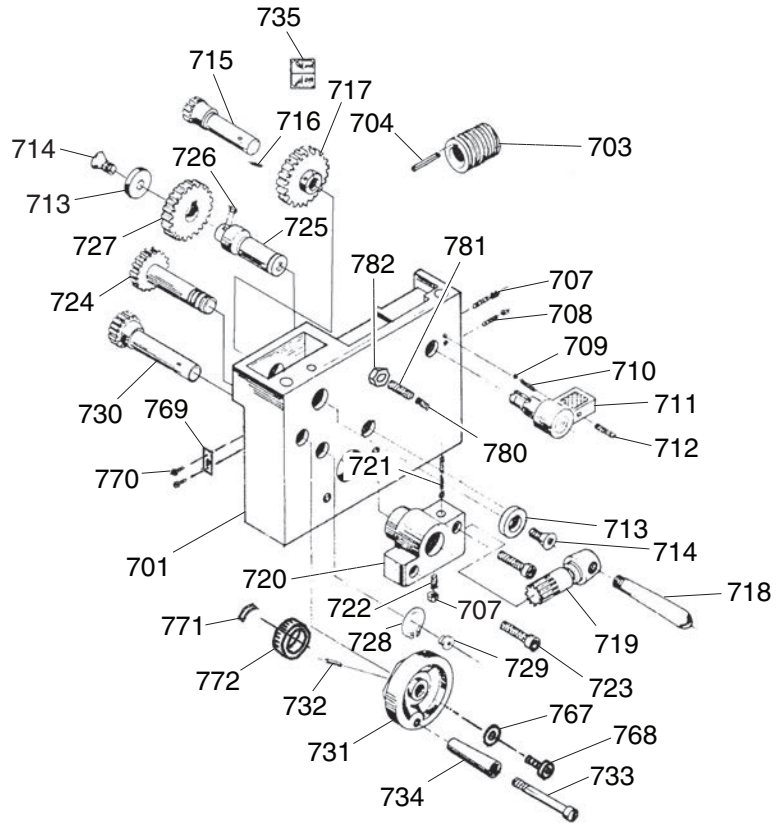

Rear View

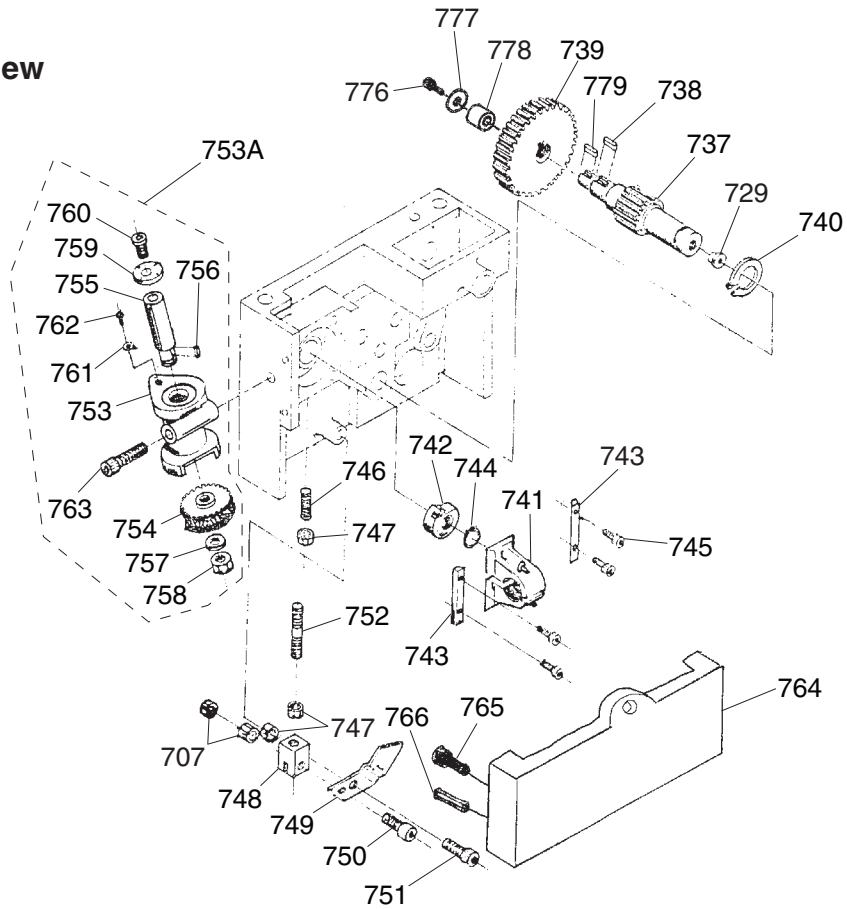

# Apron Parts List

REF	PART #	DESCRIPTION
701	P4000701	APRON CASTING
703	P4000703	WORM GEAR
704	P4000704	KEY 3 X 3 X 25
707	P4000707	HEX NUT M4-.7
708	P4000708	SET SCREW M4-.7 X 12
709	P4000709	STEEL BALL
710	P4000710	COMPRESSION SPRING
711	P4000711	HALF-NUT LEVER
712	P4000712	SET SCREW M6-1 X 6
713	P4000713	FLAT WASHER 6MM
714	P4000714	FLAT HD SCR M6-1 X 8
715	P4000715	GEAR SHAFT 12T
716	P4000716	ROLL PIN 4 X 32
717	P4000717	GEAR 43T
718	P4000718	FEED LEVER
719	P4000719	GEAR SHAFT 13T
720	P4000720	BRACKET
721	P4000721	COMPRESSION SPRING
722	P4000722	SET SCREW M4-.7 X 10
723	P4000723	CAP SCREW M6-1 X 30
724	P4000724	GEAR SHAFT 43T
725	P4000725	SHAFT
726	P4000726	KEY 4 X 4 X 10
727	P4000727	GEAR 41T
728	P4000728	EXT RETAINING RING 14MM
729	P4000729	OIL PORT 8MM
730	P4000730	GEAR SHAFT 17T
731	P4000731	HANDWHEEL
732	P4000732	ROLL PIN 4 X 24
733	P4000733	HANDLE SCREW
734	P4000734	HANDLE
735	P4000735	LEVER DIRECTION LABEL
737	P4000737	GEAR SHAFT 18T
738	P4000738	KEY 4 X 4 X 10
739	P4000739	GEAR 42T
740	P4000740	EXT RETAINING RING 12MM
741	P4000741	HALF NUT SAE 16TPI 2PC
742	P4000742	LOCKING CAM

REF	PART #	DESCRIPTION
743	P4000743	HALF-NUT GUIDE BAR
744	P4000744	EXT RETAINING RING 8MM
745	P4000745	CAP SCREW M4-.7 X 16
746	P4000746	SET SCREW M5-.8 X 25
747	P4000747	HEX NUT M5-.8
748	P4000748	CONTROL BLOCK
749	P4000749	JOINT PLATE
750	P4000750	CAP SCREW M4-.7 X 20
751	P4000751	CAP SCREW M5-.8 X 16
752	P4000752	THREADED STUD M5-.8
753	P4000753	THREAD DIAL BODY
753A	P4000753A	THREAD DIAL BODY ASSEMBLY
754	P4000754	WORM GEAR 64T
755	P4000755	SHAFT
756	P4000756	KEY 3 X 3 X 10
757	P4000757	LOCK WASHER 8MM
758	P4000758	HEX NUT M8-1.25
759	P4000759	THREAD DIAL
760	P4000760	THREAD DIAL SCREW
761	P4000761	POINTER
762	P4000762	COPPER FLUTED RIVET 2 X 4MM
763	P4000763	CAP SCREW M6-1 X 60
764	P4000764	APRON REAR COVER
765	P4000765	CAP SCREW M5-.8 X 12
766	P4000766	ROLL PIN 3 X 16
767	P4000767	HANDWHEEL FLAT WASHER
768	P4000768	HANDWHEEL CAP SCREW
769	P4000769	PLATE
770	P4000770	COPPER FLUTED RIVET 2 X 5MM
771	P4000771	INDEX PLATE
772	P4000772	GRADUATED DIAL
776	P4000776	CAP SCREW M5-.8 X 10
777	P4000777	FLAT WASHER 5MM
778	P4000778	BUSHING
779	P4000779	KEY 3 X 3 X 8
780	P4000780	THREADED BALL OILER 6MM
781	P4000781	BALL OILER SET SCREW
782	P4000782	BALL OILER THIN HEX NUT



# Saddle & Cross Slide

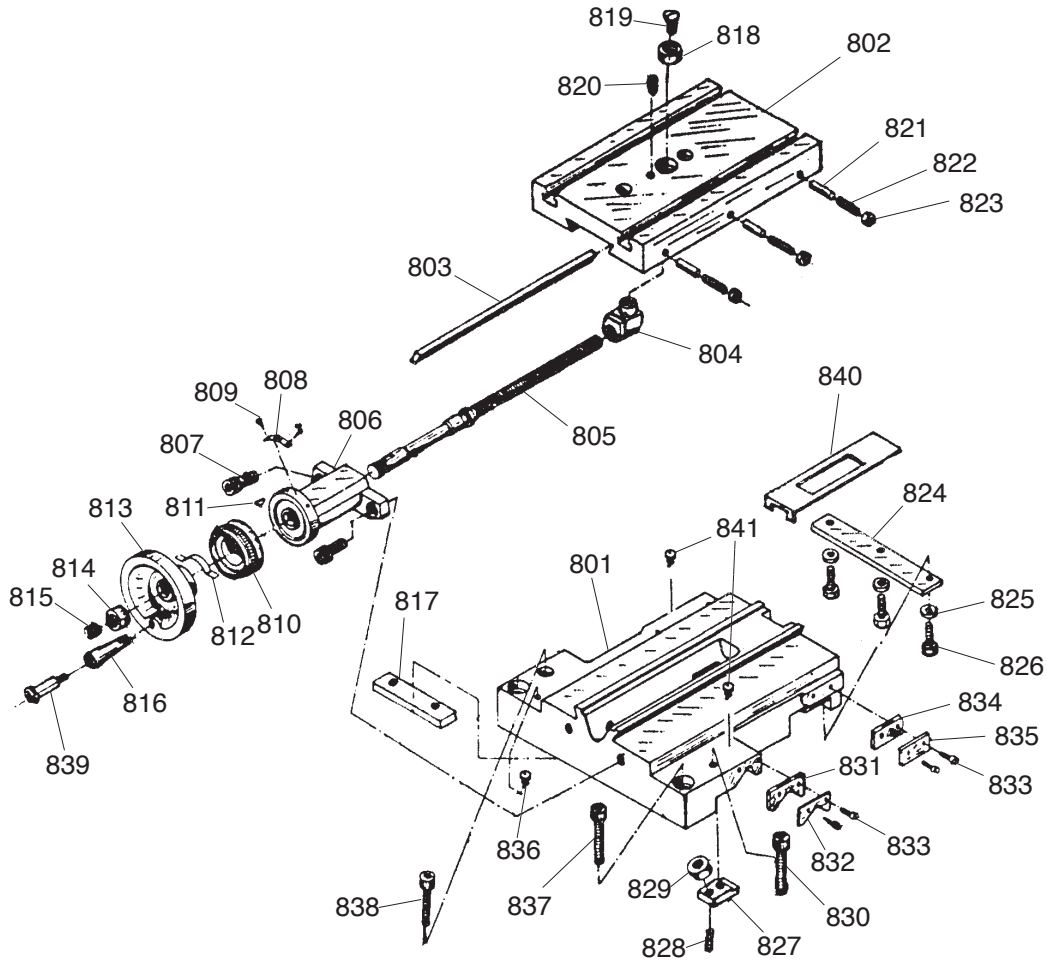

REF	PART #	DESCRIPTION
801	P4000801	SADDLE
802	P4000802	CROSS SLIDE
803	P4000803	CROSS SLIDE GIB
804	P4000804	CROSS SLIDE LEADSCREW NUT
805	P4000805	CROSS SLIDE LEADSCREW
806	P4000806	BRACKET
807	P4000807	CAP SCREW M5-.8 X 16
808	P4000808	INDEX PLATE
809	P4000809	COPPER FLUTED RIVET 2 X 4MM
810	P4000810	GRADUATED DIAL
811	P4000811	WOODRUFF KEY
812	P4000812	SPRING PLATE
813	P4000813	HANDWHEEL
814	P4000814	SPECIAL HEX NUT
815	P4000815	SET SCREW M8-1.25 X 6
816	P4000816	HANDLE
817	P4000817	SLIDE BLOCK
818	P4000818	BUSHING
819	P4000819	FLAT HD SCR M6-1 X 12
820	P4000820	SET SCREW M6-1 X 12
821	P4000821	GIB PIN

REF	PART #	DESCRIPTION
822	P4000822	SET SCREW M4-.7 X 12
823	P4000823	HEX NUT M4-.7
824	P4000824	SADDLE GIB CLAMP
825	P4000825	FLAT WASHER 6MM
826	P4000826	CAP SCREW M6-1 X 16
827	P4000827	CLIP
828	P4000828	SET SCREW M6-1 X 20
829	P4000829	HEX NUT M6-1
830	P4000830	CAP SCREW M6-1 X 25
831	P4000831	FRONT WAY WIPER
832	P4000832	FRONT WIPER CLAMP
833	P4000833	PHLP HD SCR M4-.7 X 6
834	P4000834	REAR WAY WIPER
835	P4000835	REAR WIPER CLAMP
836	P4000836	OIL PORT 6MM
837	P4000837	CAP SCREW M8-1.25 X 30
838	P4000838	CAP SCREW M6-1 X 25
839	P4000839	HANDLE SCREW
840	P4000840	CHIP GUARD
841	P4000841	TAP-IN BALL OILER 6MM



# Compound Slide

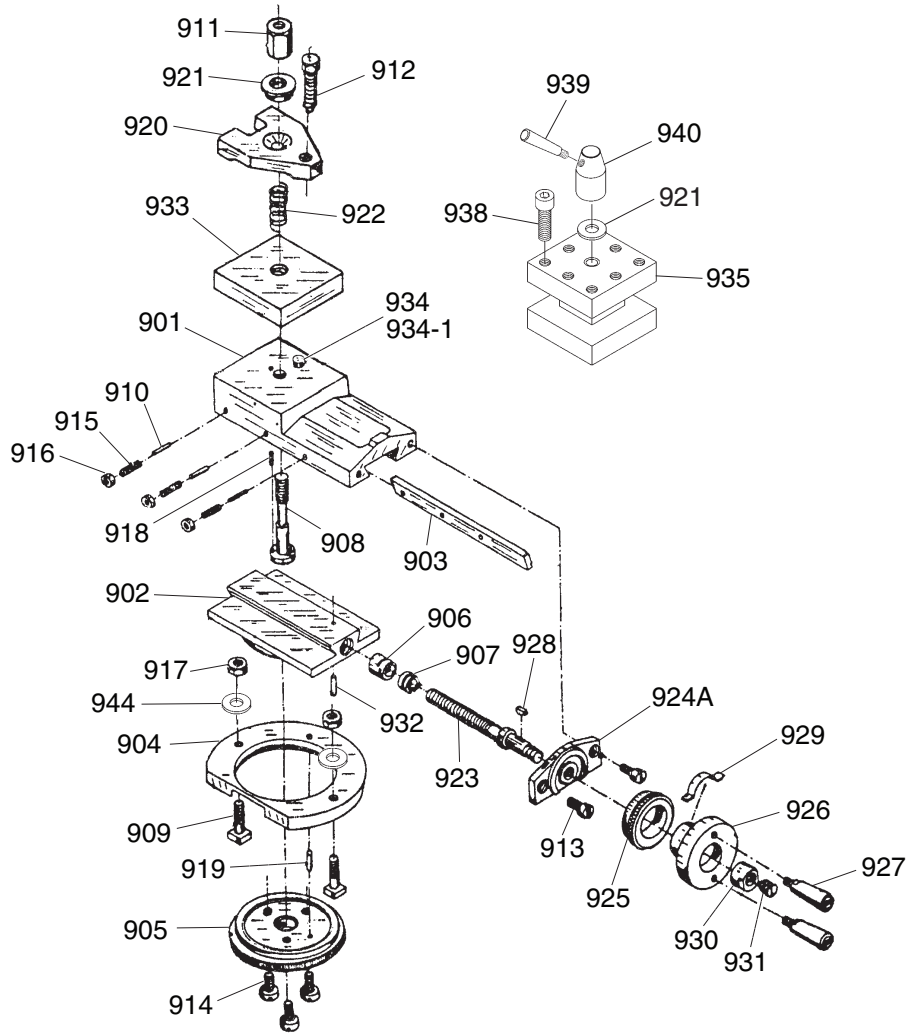

REF	PART #	DESCRIPTION
901	P4000901	COMPOUND SLIDE
902	P4000902	SWIVEL BASE
903	P4000903	COMPOUND SLIDE GIB
904	P4000904	CLAMPING RING
905	P4000905	GRADUATED DIAL
906	P4000906	COMPOUND LEADSCREW NUT
907	P4000907	ADJUSTING SCREW
908	P4000908	TOOL POST STUD
909	P4000909	CLAMPING RING T-BOLT
910	P4000910	GIB PIN
911	P4000911	TOOL POST NUT
912	P4000912	HEX BOLT M8-1.25 X 30
913	P4000913	CAP SCREW M5-.8 X 10
914	P4000914	FLAT HD SCR M6-1 X 12
915	P4000915	SET SCREW M4-.7 X 10
916	P4000916	HEX NUT M4-.7
917	P4000917	HEX NUT M6-1
918	P4000918	ROLL PIN 3 X 8
919	P4000919	ROLL PIN 3 X 14
920	P4000920	C-STYLE TOOL CLAMP

REF	PART #	DESCRIPTION
921	P4000921	FLAT WASHER 8MM
922	P4000922	COMPRESSION SPRING
923	P4000923	COMPOUND SLIDE LEADSCREW
924A	P4000924A	LEADSCREW MOUNT V2.02.07
925	P4000925	GRADUATED DIAL
926	P4000926	HANDWHEEL
927	P4000927	HANDLE
928	P4000928	KEY 3 X 13
929	P4000929	DIAL POINTER
930	P4000930	THREADED COLLAR
931	P4000931	SET SCREW M8-1.25 X 6
932	P4000932	ROLL PIN 3 X 12
933	P4000933	C-STYLE TOOL BASE
934	P4000934	TOOL POST PIN
934-1	P4000934-1	PIN SPRING
935	P4000935	4-WAY TOOL POST
938	P4000938	CAP SCREW M8-1.25 X 30
939	P4000939	LOCK HANDLE
940	P4000940	TOOL POST LOCK NUT
944	P4000944	FLAT WASHER 6MM



# Tailstock

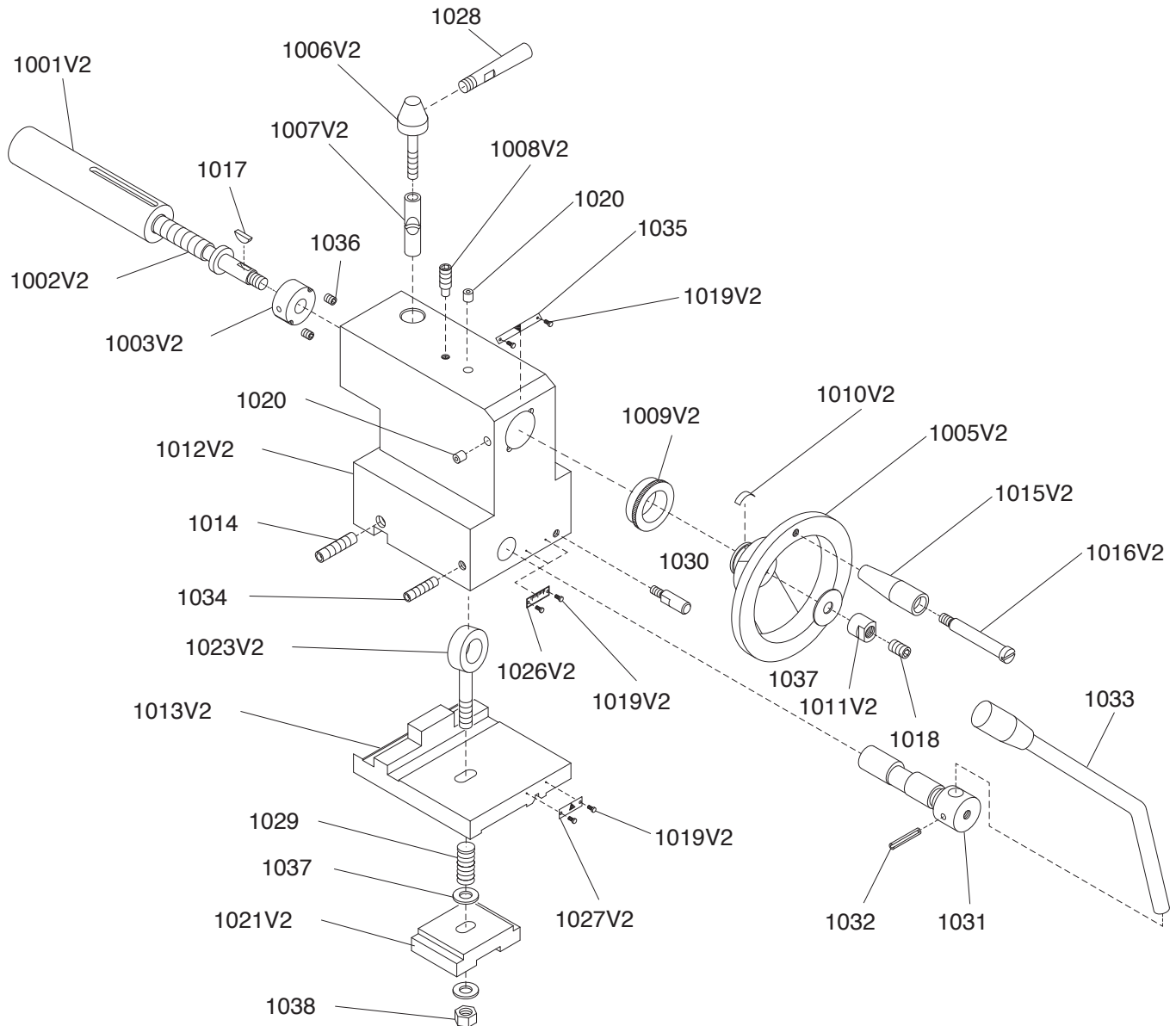

REF	PART #	DESCRIPTION
1001V2	P40001001V2	TAILSTOCK QUILL V2.12.23
1002V2	P40001002V2	TAILSTOCK LEADSCREW V2.12.23
1003V2	P40001003V2	BUSHING V2.12.23
1005V2	P40001005V2	HANDWHEEL T4 100D X 10B X M5-.8 V2.12.23
1006V2	P40001006V2	QUILL LOCK BASE V2.12.23
1007V2	P40001007V2	CLAMP V2.12.23
1008V2	P40001008V2	SET SCREW M6-1 X 12
1009V2	P40001009V2	GRADUATED DIAL V2.12.23
1010V2	P40001010V2	POINTER PLATE V2.12.23
1011V2	P40001011V2	HANDWHEEL NUT M8-1.25 V2.12.23
1012V2	P40001012V2	TAILSTOCK BODY V2.12.23
1013V2	P40001013V2	TAILSTOCK BASE V2.12.23
1014	P40001014	SET SCREW M8-1.25 X 25
1015V2	P40001015V2	HOLLOW HANDLE 14 X 40.5 V2.12.23
1016V2	P40001016V2	SHOULDER BOLT M5-.8 X 8, 7 X 40 V2.12.23
1017	P40001017	WOODRUFF KEY 3 X 13
1018	P40001018	SET SCREW M8-1.25 X 8

REF	PART #	DESCRIPTION
1019V2	P40001019V2	RIVET 2 X 4MM NAMEPLATE AL V2.12.23
1020	P40001020	OIL PORT 6MM
1021V2	P40001021V2	CLAMPING PLATE V2.12.23
1023V2	P40001023V2	TAILSTOCK CLAMP BOLT V2.12.23
1026V2	P40001026V2	UPPER OFFSET PLATE V2.12.23
1027V2	P40001027V2	LOWER OFFSET PLATE V2.12.23
1028	P40001028	FIXED HANDLE 7 X 75, M8-1.25 X 7
1029	P40001029	COMPRESSION SPRING 1 X 11 X 40
1030	P40001030	CAMLOCK STUD M5-.8 X 30
1031	P40001031	TAILSTOCK LOCK SHAFT
1032	P40001032	ROLL PIN 4 X 28
1033	P40001033	TAILSTOCK LOCK LEVER
1034	P40001034	SET SCREW M6-1 X 25
1035	P40001035	INDICATOR PLATE
1036	P40001036	SET SCREW M5-.8 X 6
1037	P40001037	FLAT WASHER 8MM
1038	P40001038	HEX NUT M8-1.25



# Steady Rest

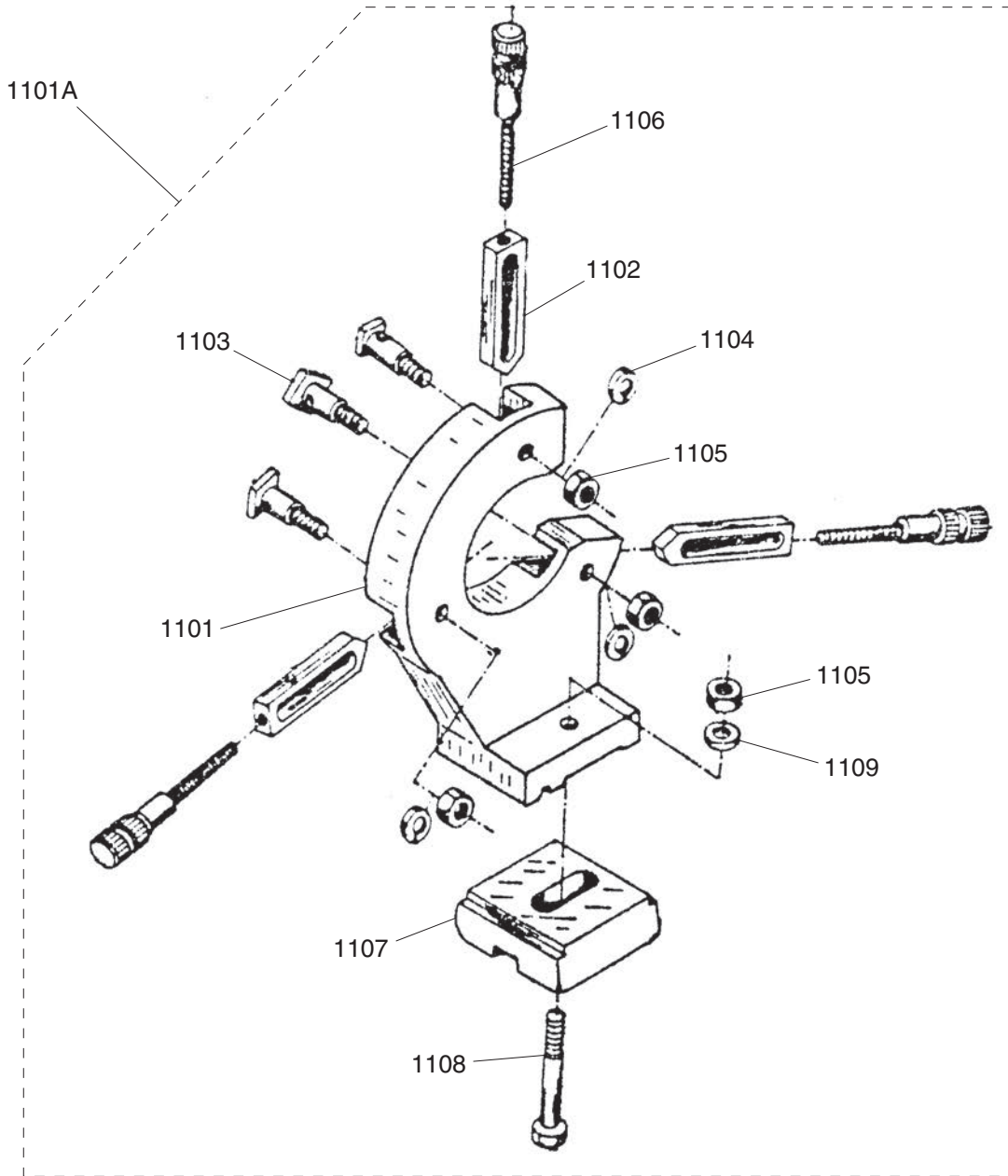

REF	PART #	DESCRIPTION
1101	P40001101	STEADY REST CASTING
1101A	P40001101A	STEADY REST ASSEMBLY
1102	P40001102	STEADY REST FINGERS 3 PC
1103	P40001103	SPECIAL SCREW
1104	P40001104	LOCK WASHER 8MM

REF	PART #	DESCRIPTION
1105	P40001105	HEX NUT M8-1.25
1106	P40001106	ADJUSTING SCREW
1107	P40001107	CLAMPING PLATE
1108	P40001108	HEX BOLT M8-1.25 X 60
1109	P40001109	FLAT WASHER 8MM



# Follow Rest

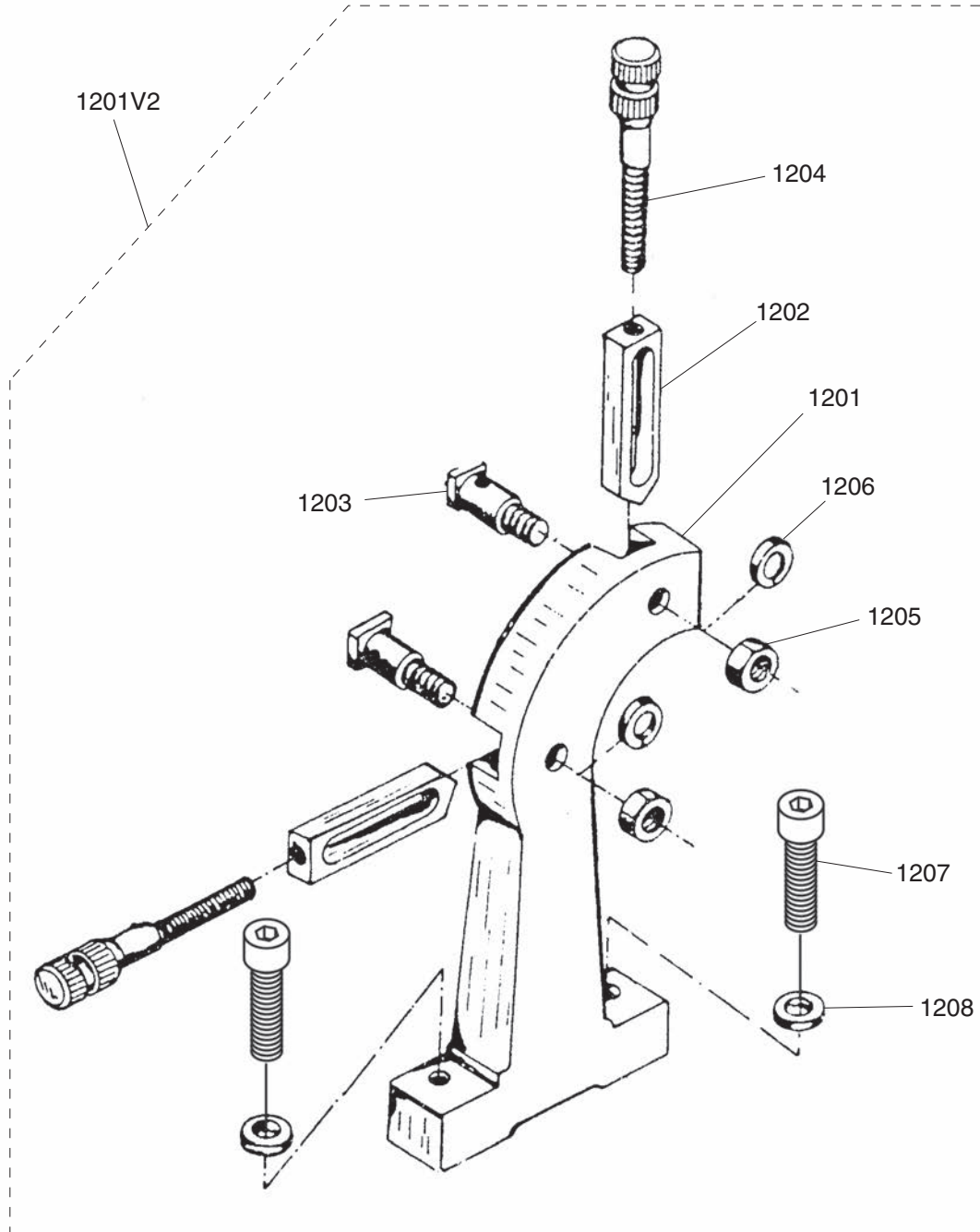

REF	PART #	DESCRIPTION
1201	P40001201	FOLLOW REST CASTING
1201V2	P40001201V2	FOLLOW REST ASSEMBLY V2.01.09
1202	P40001202	FOLLOW REST FINGER 2PC SET
1203	P40001203	SPECIAL SCREW
1204	P40001204	ADJUSTING SCREW

REF	PART #	DESCRIPTION
1205	P40001205	HEX NUT M8-1.25
1206	P40001206	FLAT WASHER 8MM
1207	P40001207	CAP SCREW M6-1 X 30
1208	P40001208	FLAT WASHER 6MM



# Bed

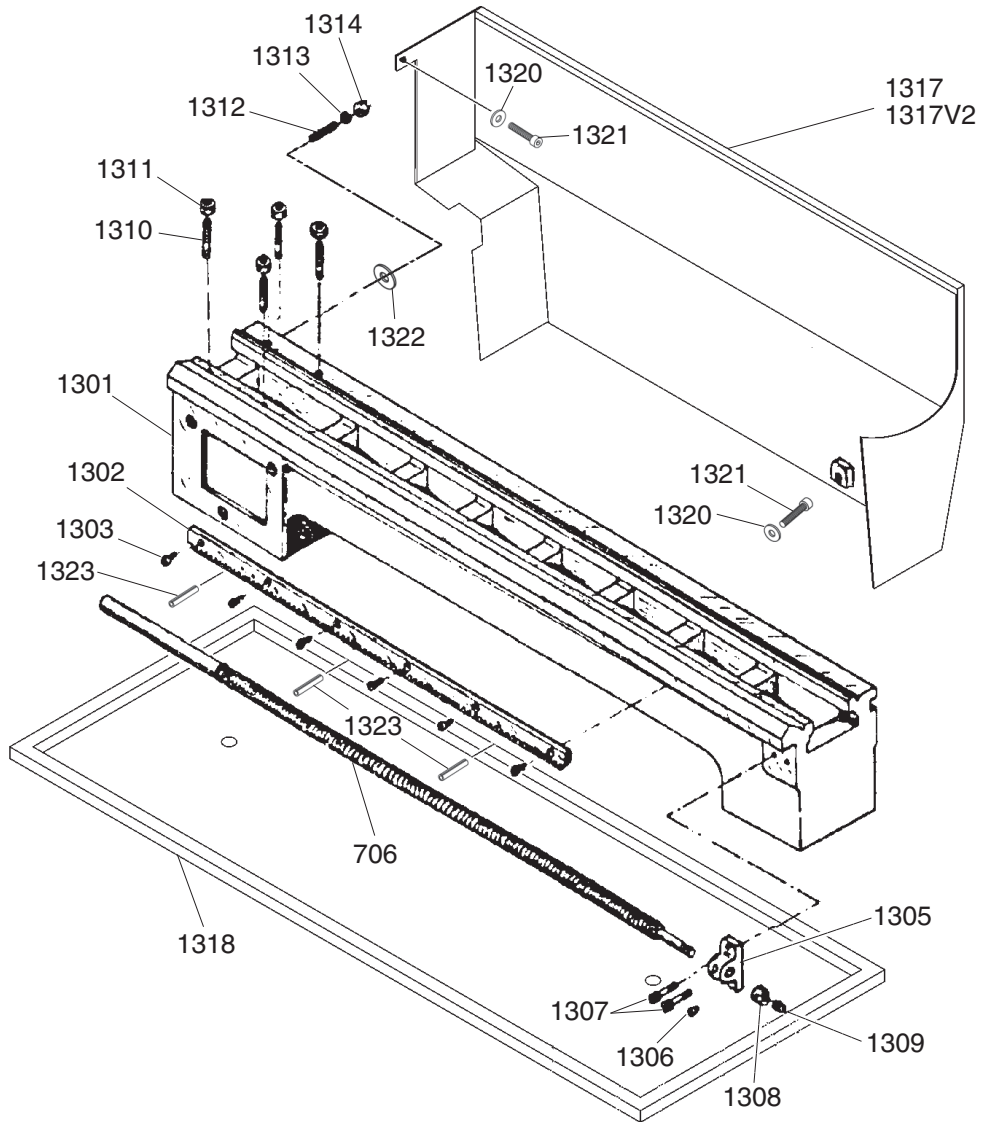

REF	PART #	DESCRIPTION
706	P4000706	LEADSCREW 9/16-16 x 25"
1301	P40001301	BED
1302	P40001302	RACK
1303	P40001303	CAP SCREW M4-.7 X 8
1305	P40001305	LEADSCREW BUSHING BLOCK
1306	P40001306	OIL PORT
1307	P40001307	CAP SCREW M6-1 X 20
1308	P40001308	HEX NUT M8-1.25
1309	P40001309	SET SCREW M8-1.25 X 6
1310	P40001310	THREADED STUD M8-1.25 X 28
1311	P40001311	HEX NUT M8-1.25

REF	PART #	DESCRIPTION
1312	P40001312	SET SCREW M6-1 X 25
1313	P40001313	FLAT WASHER 6MM
1314	P40001314	HEX NUT M6-1
1317	P40001317	CHIP SHIELD GREEN V1.06.97
1317V2	P40001317V2	CHIP SHIELD WHITE V2.01.08
1318	P40001318	CHIP PAN
1320	P40001320	FLAT WASHER 5MM
1321	P40001321	CAP SCREW M5-.8 X 10
1322	P40001322	FENDER WASHER 6MM
1323	P40001323	ROLL PIN 4 X 16



# Label Placement

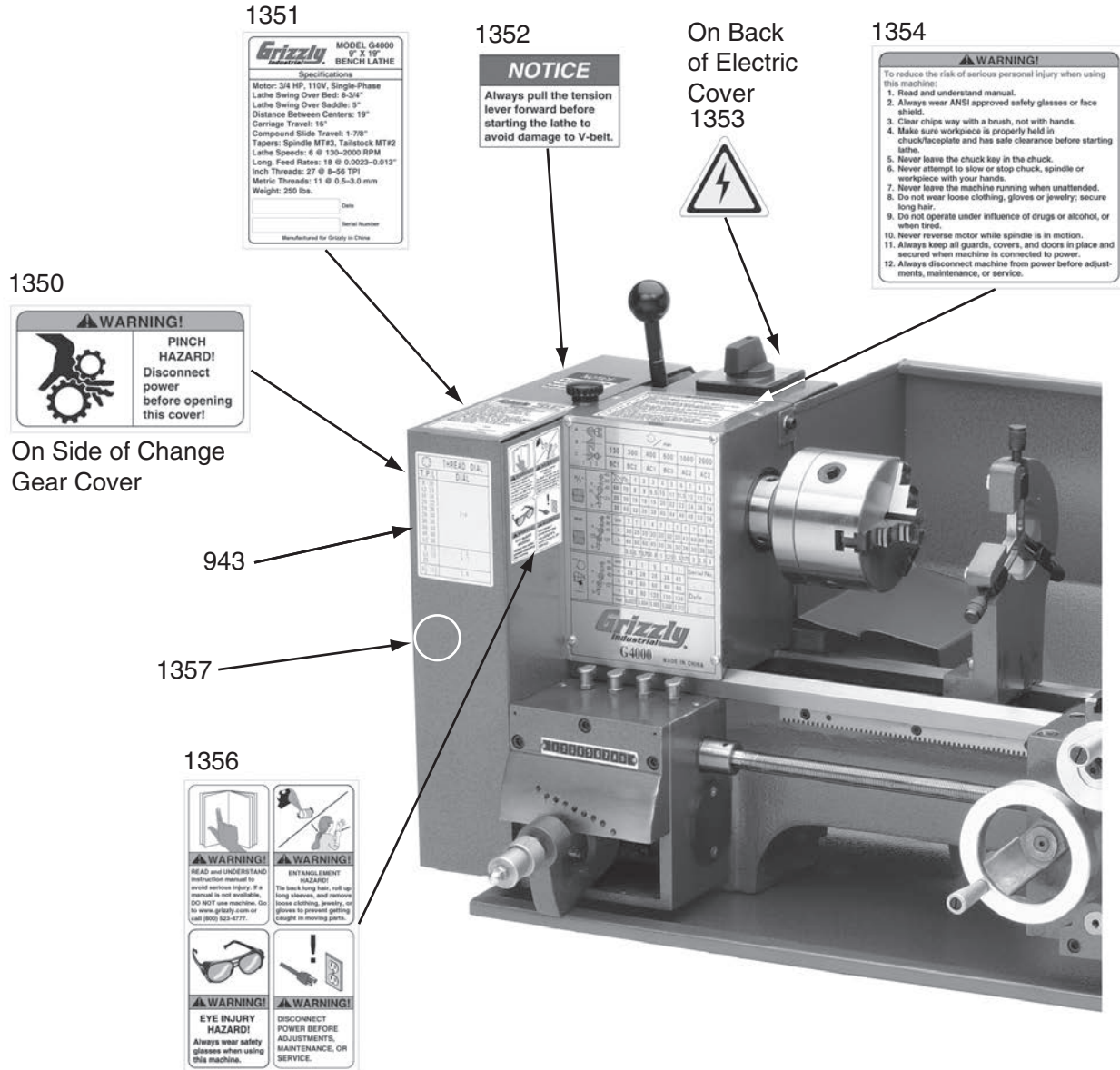

REF	PART #	DESCRIPTION
943	P4000943	THREAD DIAL CHART LABEL
1350	P40001350	PINCH HAZARD LABEL
1351	P40001351	MACHINE ID LABEL
1352	P40001352	TENSION LEVER NOTICE LABEL

REF	PART #	DESCRIPTION
1353	P40001353	ELECTRICITY LABEL
1354	P40001354	WARNINGS LABEL
1356	P40001356	GROUPED WARNINGS LABEL
1357	P40001357	GRIZZLY GREEN TOUCH-UP PAINT

## WARNING

Safety labels warn about machine hazards and ways to prevent injury. The owner of this machine **MUST** maintain the original location and readability of the labels on the machine. If any label is removed or becomes unreadable, **REPLACE** that label before using the machine again. Contact Grizzly at (800) 523-4777 or [www.grizzly.com](http://www.grizzly.com) to order new labels.

