

READ THIS FIRST



For questions or help with this product contact Tech Support at (570) 546-9663 or techsupport@grizzly.com

Model G0561

IMPORTANT UPDATE

For Machines Mfd. Since 01/25
and Owner's Manual Revised 11/22

The following changes were recently made since the owner's manual was printed:

- New coolant pump and vise design.
- Specifications, parts, wiring, and labels changed.

Aside from this information, all other content in the owner's manual applies and **MUST** be read and understood for your own safety. **IMPORTANT: Keep this update with the owner's manual for future reference.**

For questions or help, contact our Tech Support at (570) 546-9663 or techsupport@grizzly.com.

New Coolant Pump



Old Coolant Pump



COPYRIGHT © NOVEMBER, 2024 BY GRIZZLY INDUSTRIAL, INC.
**WARNING: NO PORTION OF THIS MANUAL MAY BE REPRODUCED IN ANY SHAPE
OR FORM WITHOUT THE WRITTEN APPROVAL OF GRIZZLY INDUSTRIAL, INC.**
#CS23350 PRINTED IN TAIWAN

Revised Parts

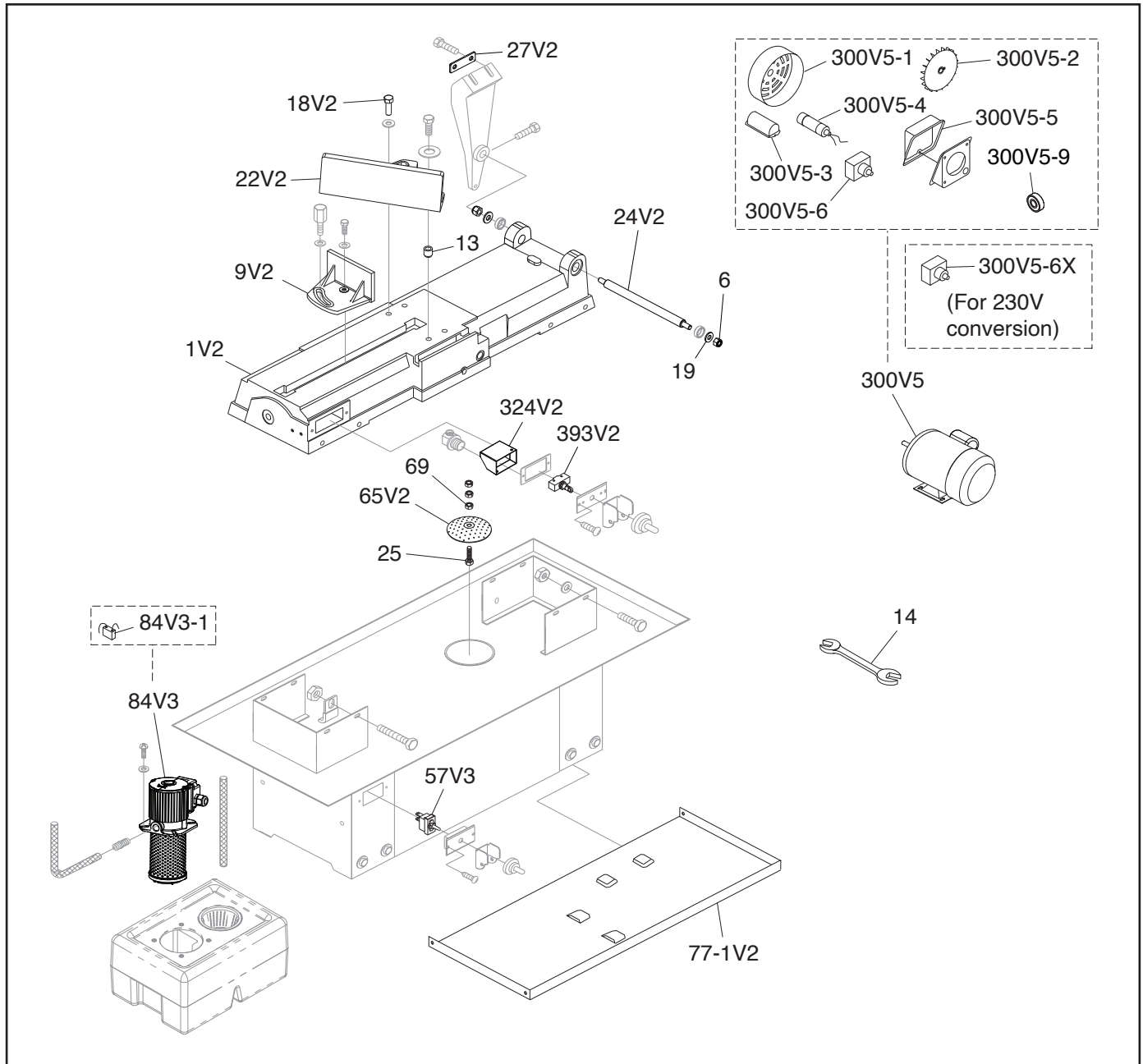

REF	PART #	DESCRIPTION
1V2	P0561001V2	BASE V2.01.25
6	P0561006	LOCK NUT 1/2"-12
9V2	P0561009V2	WISE JAW, FRONT V2.01.25
13	P0561013	BUSHING
14	P0561014	WRENCH 17 X 19MM OPEN-ENDS
18V2	P0561018V2	HEX BOLT 1/2-12 X 2 V2.01.25
19	P0561019	FLAT WASHER 1/2
22V2	P0561022V2	WISE JAW, REAR V2.01.25
24V2	P0561024V2	SUPPORT ROD V2.01.25
25	P0561025	HEX BOLT 5/16-18 X 3/4
27V2	P0561027V2	SPRING BRACKET 75 X 25.4 V2.01.25
57V3	P0561057V3	TOGGLE SWITCH SEI R13-25A V3.01.25
65V2	P0561065V2	DRAIN SCREEN V2.01.25
69	P0561069	HEX NUT 5/16-18

REF	PART #	DESCRIPTION
77-1V2	P0561077-1V2	STAND SHELF V2.09.23
84V3	P0561084V3	COOLANT PUMP MOTOR V3.01.24
84V3-1	P0561084V3-1	R CAPACITOR 3M 400V 1-1/8 X 1-1/2
300V5	P0561300V5	MOTOR 1HP 115/230V 1-PH V5.01.25
300V5-1	P0561300V5-1	MOTOR FAN COVER
300V5-2	P0561300V5-2	MOTOR FAN
300V5-3	P0561300V5-3	CAPACITOR COVER
300V5-4	P0561300V5-4	S CAPACITOR 150M 250V
300V5-5	P0561300V5-5	JUNCTION BOX
300V5-6	P0561300V5-6	CIRCUIT BREAKER 18A KUOYUH 88-SERIES
300V5-6X	P0561300V5-6X	CIRCUIT BREAKER 10A KUOYUH 88-SERIES
300V5-9	P0561300V5-9	BALL BEARING 6203ZZ
324V2	P0561324V2	ELECTRICAL BOX V2.01.25
393V2	P0561393V2	TOGGLE SWITCH SEI R13-28F V2.01.25



Labels & Cosmetics

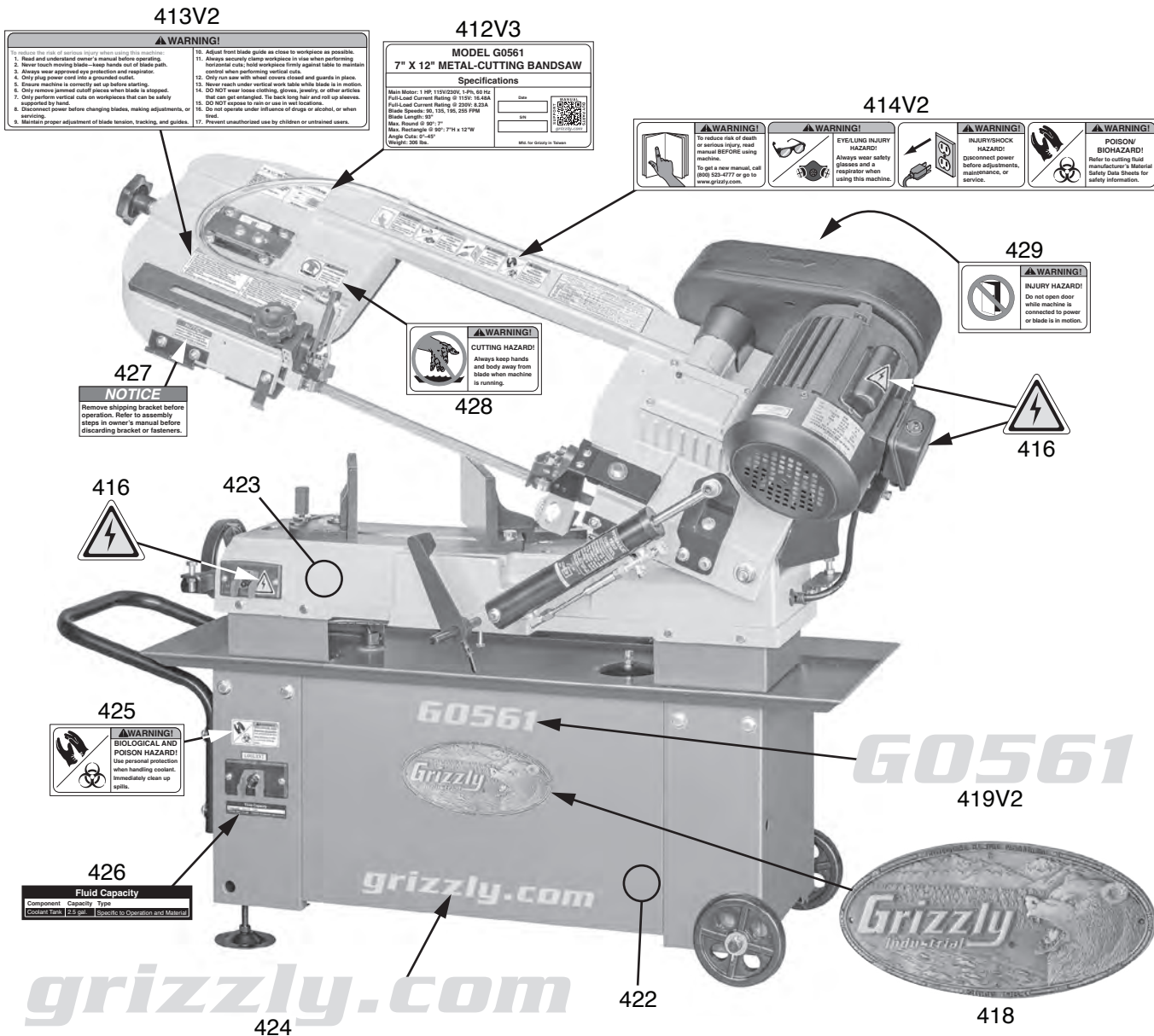

REF	PART #	DESCRIPTION
412V3	P0561412V3	MACHINE ID LABEL V3.01.25
413V2	P0561413V2	MACHINE WARNING LABEL V2.09.23
414V2	P0561414V2	COMBO WARNING LABEL V2.09.23
416	P0561416	ELECTRICITY LABEL
418	P0561418	GRIZZLY NAMEPLATE, SMALL
419V2	P0561419V2	MODEL NUMBER LABEL V2.09.23
422	P0561422	TOUCH-UP PAINT, GRIZZLY GREEN

REF	PART #	DESCRIPTION
423	P0561423	TOUCH-UP PAINT, GRIZZLY PUTTY
424	P0561424	GRIZZLY.COM LABEL
425	P0561425	BIOLOGICAL & POISON HAZARD
426	P0561426	FLUID CAPACITY LABEL
427	P0561427	REMOVE BRACKET NOTICE
428	P0561428	CUTTING HAZARD LABEL
429	P0561429	DO NOT OPEN DOOR LABEL

⚠ WARNING
 Safety labels help reduce the risk of serious injury caused by machine hazards. If any label comes off or becomes unreadable, the owner of this machine **MUST** replace it in the original location before resuming operations. For replacements, contact (800) 523-4777 or www.grizzly.com.

BUY PARTS ONLINE AT GRIZZLY.COM!
 Scan QR code to visit our Parts Store.





Cabinet & Base Parts List

REF	PART #	DESCRIPTION
1	P0561001	BASE
2	P0561002	ACME SCREW 22 X 5 X 480
3	P0561003	FLAT WASHER 1/2
4	P0561004	KEY 5 X 5 X 15
5	P0561005	HANDWHEEL
5-1	P0561005-1	HANDWHEEL HANDLE
7	P0561007	KNOB BOLT 3/8-16
8	P0561008	FLAT WASHER 3/8
9	P0561009	WISE JAW, FRONT
10	P0561010	ROLL PIN 5 X 34
11	P0561011	BRACKET
12	P0561012	ACME NUT ASSY 22 X 5
17	P0561017	HEX BOLT 3/8-16 X 1-1/2
18	P0561018	HEX NUT 1/2-12
19	P0561019	FLAT WASHER 1/2
20	P0561020	CARRIAGE BOLT 1/2-12 X 2
21	P0561021	HEX BOLT 1/2-12 X 2
22	P0561022	WISE JAW, REAR
23	P0561023	BUSHING
24	P0561024	SUPPORT ROD
25	P0561025	HEX BOLT 5/16-18 X 3/4
26	P0561026	PIVOT BRACKET
27	P0561027	SPRING BRACKET 75 X 25.4
28	P0561028	HEX BOLT 3/8-16 X 1-1/2
29	P0561029	SUPPORT PLATE
30	P0561030	FIXED PLATE
31	P0561031	TENSION SPRING 32 X 282
32	P0561032	EYE BOLT 3/8-16 X 4-1/2
33	P0561033	SPRING HANDLE BRACKET
34	P0561034	HEX BOLT 5/16-18 X 3/4
35	P0561035	FLAT WASHER 5/16
36	P0561036	HEX NUT 3/8-16
37	P0561037	FLAT WASHER 3/8
38	P0561038	LEAF SCREW 5/16-18
39	P0561039	HEX BOLT 5/16-18 X 3/4
40	P0561040	WORK STOP ROD
41	P0561041	WORK STOP
42	P0561042	HEX BOLT 5/16-18 X 1-1/2
43	P0561043	HEX NUT 5/16-18
45	P0561045	SUPPORT PLATE
46	P0561046	HEX BOLT 3/8-16 X 1-3/4
47	P0561047	HEX NUT 3/8-16
48	P0561048	HEX BOLT 5/16-18 X 3/4
49	P0561049	FLAT WASHER 5/16
50	P0561050	HEX BOLT 3/8-16 X 1-3/4
51	P0561051	HEX NUT 3/8-16
52	P0561052	HEX BOLT 5/16-18 X 3/4
53	P0561053	LOCK WASHER 5/16
55	P0561055	ELECTRICAL BOX GASKET, RUBBER
57V2	P0561057V2	TOGGLE SWITCH KEDU HY29H V2.01.08
59	P0561059	PHLP HD SCR 10-24 X 3/8
65	P0561065	DRAIN SCREEN

REF	PART #	DESCRIPTION
66	P0561066	SWITCH SHUT-OFF TIP
67	P0561067	HEX BOLT 3/8-16 X 1-1/4
68	P0561068	FLAT WASHER 5/16
69	P0561069	HEX NUT 5/16-18
70	P0561070	SWITCH BRACKET
71	P0561071	TOGGLE SWITCH COVER
72	P0561072	HEX BOLT 5/16-18 X 1
75	P0561075	PHLP HD SCR 10-24 X 3/8
77	P0561077	STAND ASSEMBLY
77-1	P0561077-1	STAND SHELF
78	P0561078	HOSE 12 X 8 X 200MM
82	P0561082	COOLANT TANK
83	P0561083	COOLANT PUMP SWITCH CORD 16G 3W 26"
84V2	P0561084V2	COOLANT PUMP MOTOR V2.07.09
84V2-1	P0561084V2-1	R CAPACITOR 3MFD 450V 1-1/8 X 1-1/2
85	P0561085	PHLP HD SCR 1/4-20 X 5/8
86	P0561086	FLAT WASHER 1/4
87	P0561087	COOLANT PUMP CORD 18G 3W 23"
88	P0561088	HOSE COUPLER 3/8 NPT X 5/16
89	P0561089	HOSE CLIP 5/8"
90	P0561090	HOSE 12 X 8 X 2000MM
91	P0561091	VALVE ASSEMBLY
94	P0561094	STAND WHEEL AXLE
95	P0561095	STAND WHEEL
96	P0561096	COTTER PIN 3 X 25MM STANDARD
97	P0561097	CYLINDER ASSEMBLY RF-712N
99	P0561099	FLAT WASHER 5/16
100	P0561100	HEX BOLT 5/16-18 X 1
101	P0561101	CAP SCREW 3/8-16 X 2-1/4
102	P0561102	FLAT WASHER 3/8
135	P0561135	FLAT WASHER 5/16
136	P0561136	HEX BOLT 5/16-18 X 3/4
137	P0561137	FLAT WASHER 5/8
316	P0561316	SCALE
324	P0561324	ELECTRICAL BOX
325	P0561325	SWITCH COVER
326	P0561326	PHLP HD SCR 10-24 X 3/8
333	P0561333	FLAT WASHER #10
335	P0561335	STRAIN RELIEF M18.5 TYPE-6 ST
341	P0561341	CYLINDER SUPPORT, LOWER
342	P0561342	CYLINDER SUPPORT, UPPER
352	P0561352	FLAT WASHER 5/16
353	P0561353	HEX BOLT 5/16-18 X 1/2
354	P0561354	SPACER 8 X 16 X 2
355	P0561355	HEX NUT 3/8-16
370	P0561370	STRAIN RELIEF 1/2 NPT NYLON
393	P0561393	TOGGLE SWITCH KEDU HY29H
408	P0561408	HEX NUT 5/16-18
409	P0561409	FLAT WASHER 5/16
410	P0561410	HEX BOLT 5/16-18 X 1-1/4
411	P0561411	LEVELING FOOT 3/8-16 x 3
421	P0561421	FLAT WASHER 3/8

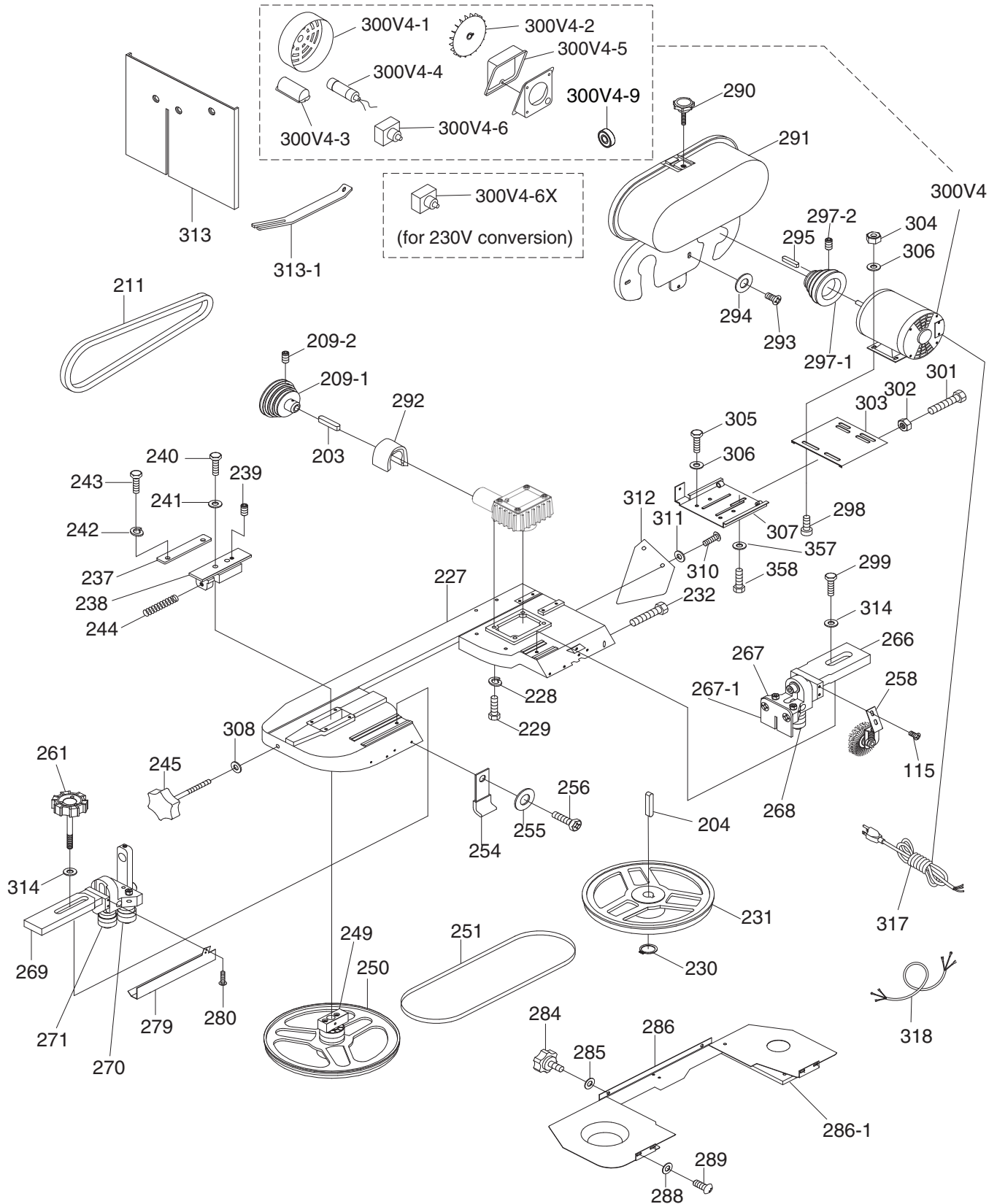

Bow & Motor



Please Note: We do our best to stock replacement parts whenever possible, but we cannot guarantee that all parts shown here are available for purchase. Call (800) 523-4777 or visit our online parts store at www.grizzly.com to check for availability.

Model G0561 (Mfd. Since 01/18)



BUY PARTS ONLINE AT GRIZZLY.COM!
Scan QR code to visit our Parts Store.



Bow & Motor Parts List

REF	PART #	DESCRIPTION
115	P0561115	PHLP HD SCR M5-.8 X 8
203	P0561203	KEY 5 X 5 X 30
204	P0561204	KEY 6 X 6 X 20
209-1	P0561209-1	SPINDLE PULLEY
209-2	P0561209-2	SET SCREW M6-1 X 10
211	P0561211	V-BELT M27 3L270
227	P0561227	BODY FRAME
228	P0561228	LOCK WASHER 3/8
229	P0561229	HEX BOLT 3/8-16 X 1-1/4
230	P0561230	EXT RETAINING RING 25MM
231	P0561231	DRIVE WHEEL
232	P0561232	HEX BOLT 5/16-18 X 3/4
237	P0561237	SLIDING PLATE
238	P0561238	BLADE TENSION SLIDING BLOCK
239	P0561239	SET SCREW 5/16-18 X 3/4
240	P0561240	HEX BOLT 5/16-18 X 1-1/2
241	P0561241	FLAT WASHER 5/16
242	P0561242	LOCK WASHER 5/16
243	P0561243	HEX BOLT 5/16-18 X 3/4
244	P0561244	COMPRESSION SPRING 115 X 4
245	P0561245	KNOB BOLT M10-1.5 X 50
249	P0561249	WHEEL SHAFT ASSEMBLY
250	P0561250	IDLER WHEEL
251	P0561251	BLADE 0.032 X 3/4 X 93 X 8T
254	P0561254	SWITCH SHUT-OFF LATCH
255	P0561255	FLAT WASHER 1/4
256	P0561256	PHLP HD SCR 1/4-20 X 1/2
258	P0561258	BRUSH ASSEMBLY
261	P0561261	KNOB BOLT M10-1.5 X 35
266	P0561266	ADJUST BRACKET ASSEMBLY, REAR
267	P0561267	ECCENTRIC GUIDE BEARING ASSEMBLY
267-1	P0561267-1	DEFLECTOR PLATE
268	P0561268	NON-ECCENTRIC BEARING SHAFT ASSEMBLY
269	P0561269	ADJUST BRACKET ASSEMBLY, FRONT
270	P0561270	GUIDE PIVOT ASSEMBLY
271	P0561271	NON-ECCENTRIC BEARING SHAFT ASSEMBLY
279	P0561279	BLADE COVER, FRONT
280	P0561280	PHLP HD SCR 8-32 X 1/4
284	P0561284	KNOB BOLT 1/4" X 20 x 3/8
285	P0561285	FLAT WASHER 1/4

REF	PART #	DESCRIPTION
286	P0561286	BLADE BACK COVER
286-1	P0561286-1	BLADE BACK COVER PLATE
288	P0561288	FLAT WASHER 1/4
289	P0561289	PHLP HD SCR 1/4-20 X 1/2
290	P0561290	KNOB BOLT 1/4" X 20 x 3/8
291	P0561291	MOTOR PULLEY COVER
292	P0561292	SHAFT COVER
293	P0561293	PHLP HD SCR 1/4-20 X 1
294	P0561294	FLAT WASHER 1/4
295	P0561295	KEY 5 X 5 X 30
297-1	P0561297-1	MOTOR PULLEY
297-2	P0561297-2	SET SCREW 1/4-20 X 3/8
298	P0561298	CARRIAGE BOLT 5/16-18 X 1
299	P0561299	HEX BOLT 3/8-16 X 1-1/4
300V4	P0561300V4	MOTOR 1HP 115/230V 1-PH V4.01.18
300V4-1	P0561300V4-1	MOTOR FAN COVER
300V4-2	P0561300V4-2	MOTOR FAN
300V4-3	P0561300V4-3	CAPACITOR COVER
300V4-4	P0561300V4-4	S CAPACITOR 400MFD 250V 1-3/4 X 3-1/4
300V4-5	P0561300V4-5	JUNCTION BOX
300V4-6	P0561300V4-6	CIRCUIT BREAKER 13A KUOYUH 88-SERIES 1P
300V4-6X	P0561300V4-6X	CIRCUIT BREAKER 7A KUOYUH 88-SERIES 1P
300V4-9	P0561300V4-9	BALL BEARING 6203-2RS
301	P0561301	HEX BOLT 5/16-18 X 1-1/2
302	P0561302	HEX NUT 5/16-18
303	P0561303	MOTOR MOUNT
304	P0561304	HEX NUT 5/16-18
305	P0561305	HEX BOLT 5/16-18 X 3/4
306	P0561306	FLAT WASHER 5/16
307	P0561307	MOTOR MOUNT BRACKET
308	P0561308	FLAT WASHER 3/8
311	P0561311	FLAT WASHER 1/4
312	P0561312	SUPPORT PLATE
313	P0561313	VERTICAL SAW TABLE
313-1	P0561313-1	TABLE BRACKET
314	P0561314	FLAT WASHER 3/8
317	P0561317	POWER CORD 14G 3W 84" 5-15 V3.01.08
318	P0561318	POWER SWITCH CORD 14G 3W 54"
357	P0561357	FLAT WASHER 5/16
358	P0561358	HEX BOLT 5/16-18 X 1



Gearbox

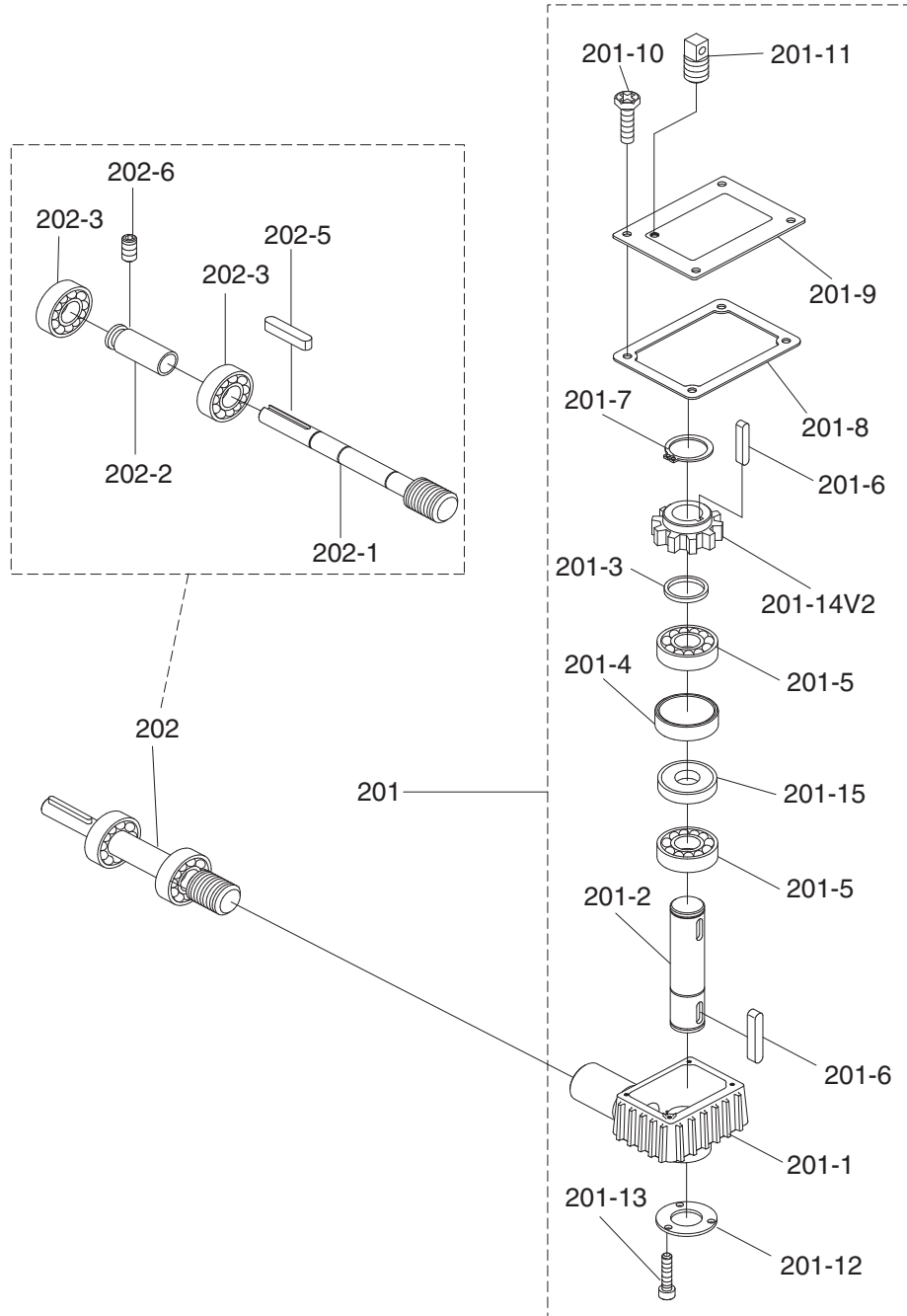

REF	PART #	DESCRIPTION
201	P0561201	GEARBOX ASSY
201-1	P0561201-1	GEARBOX HOUSING
201-2	P0561201-2	TRANSMISSION WHEEL SHAFT
201-3	P0561201-3	SPACER
201-4	P0561201-4	SPACER
201-5	P0561201-5	BALL BEARING 6205ZZ
201-6	P0561201-6	KEY 6 X 6 X 20
201-7	P0561201-7	EXT RETAINING RING 25MM
201-8	P0561201-8	GEARBOX GASKET
201-9	P0561201-9	GEARBOX COVER
201-10	P0561201-10	FLAT HD SCR 1/4-20 X 1/2

REF	PART #	DESCRIPTION
201-11	P0561201-11	VENT PLUG
201-12	P0561201-12	BEARING COVER
201-13	P0561201-13	PHLP HD SCR 10-24 X 3/8
201-14V2	P0561201-14V2	WORM GEAR STEEL V2.10.11
201-15	P0561201-15	OIL SEAL 25 X 52 X 10
202	P0561202	WORM GEAR SHAFT ASSEMBLY
202-1	P0561202-1	WORM SHAFT
202-2	P0561202-2	BEARING BUSHING
202-3	P0561202-3	BALL BEARING 6003ZZ
202-5	P0561202-5	KEY 5 X 5 X 30
202-6	P0561202-6	SET SCREW 5/16-18 X 1/2



Labels & Cosmetics

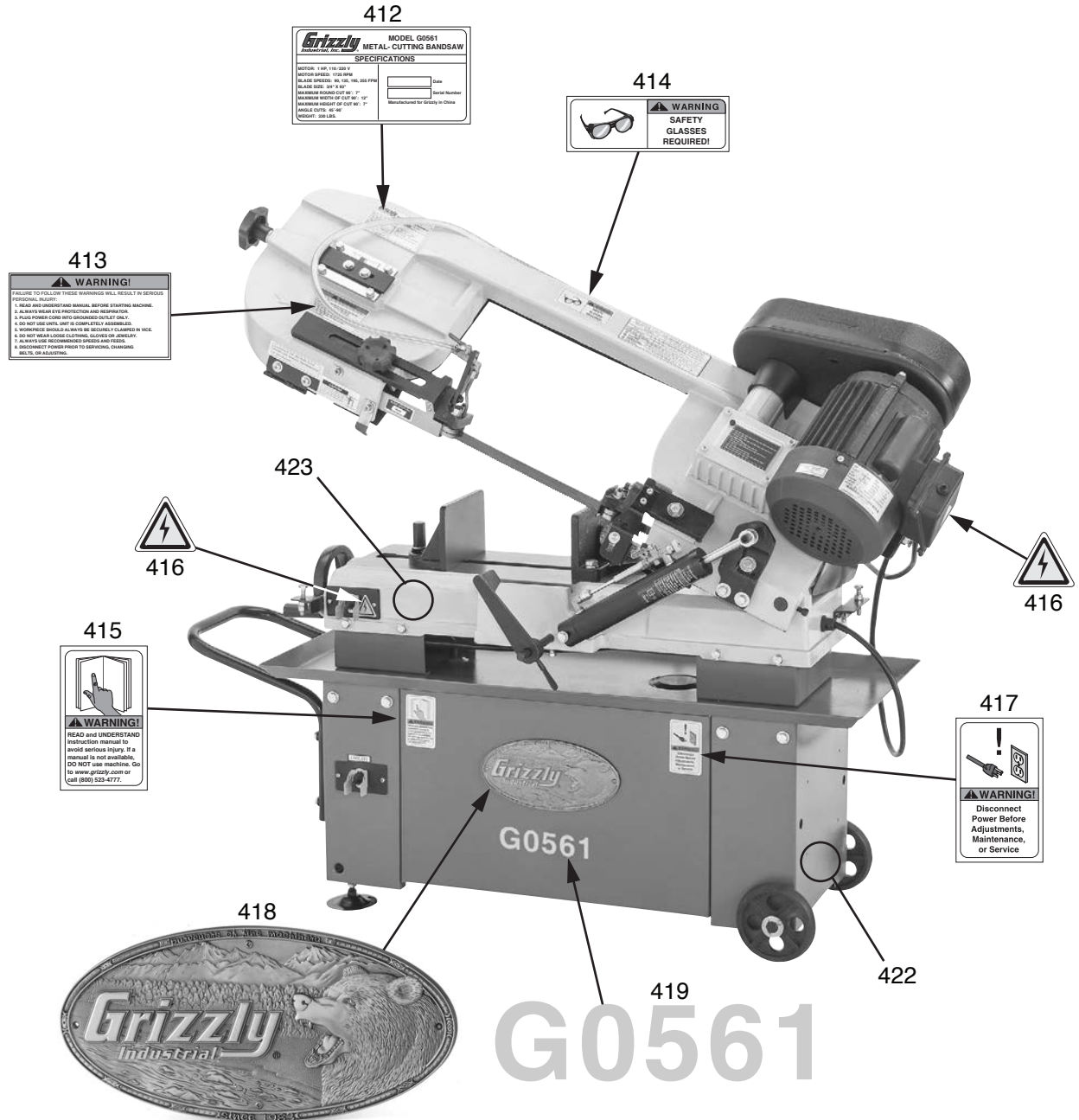

REF PART #	DESCRIPTION
412	P0561412 MACHINE ID LABEL
413	P0561413 MACHINE WARNING LABEL
414	P0561414 SAFETY GLASSES LABEL
415	P0561415 READ MANUAL LABEL
416	P0561416 ELECTRICITY LABEL

REF PART #	DESCRIPTION
417	P0561417 UNPLUG BANDSAW LABEL
418	P0561418 GRIZZLY NAMEPLATE, SMALL
419	P0561419 MODEL NUMBER LABEL
422	P0561422 TOUCH-UP PAINT, GRIZZLY GREEN
423	P0561423 TOUCH-UP PAINT, GRIZZLY PUTTY

⚠ WARNING

Safety labels help reduce the risk of serious injury caused by machine hazards. If any label comes off or becomes unreadable, the owner of this machine **MUST** replace it in the original location before resuming operations. For replacements, contact (800) 523-4777 or www.grizzly.com.

