

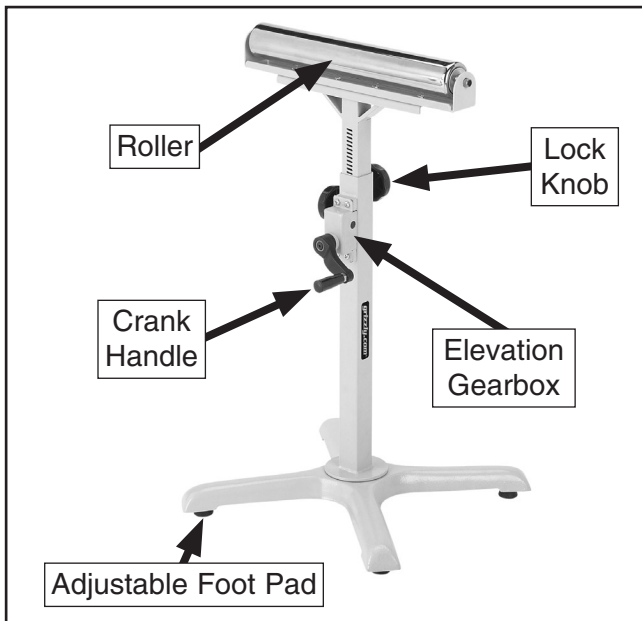

# MODEL T10114 HEAVY-DUTY ROLLER STAND INSTRUCTIONS

## Introduction

The Model T10114 Heavy-Duty Roller Stand is vertically adjustable from 26¼" to 41" with the use of a crank handle and the attached elevation gears, as shown in **Figure 1**. This stand has a 270 lb. capacity.



**Figure 1.** Model T10114 identification.

## Inventory

After removing the contents of the shipping package, lay them out and refer to the **Parts Breakdown** on the back page to inventory the components.

*If you need help with your new roller stand, call our Tech Support at: (570) 546-9663.*

## Assembly

Refer to **Figure 1** and the **Parts Breakdown** illustration to aid you during assembly.

Tools Needed	Qty
Phillips Screwdriver .....	1
Hex Wrench 3mm.....	1
Wrench or Socket 10, 13mm .....	1 Each

### To assemble your roller stand:

1. Thread the four foot pads into the base.
2. Secure the bottom vertical support onto the base by threading the ⅜"-16 x 1" hex bolt, lock washers, and flat washers through the bottom of the base and into the support.
3. Insert the top vertical support into the bottom support with the horizontal slits facing toward the gear assembly mounting.
4. Position the elevation gearbox onto its mounting point and make sure the gear teeth mesh with the slits in the top vertical support, then secure the gearbox with the four ¼"-20 x ½" Phillips head screws.
5. Align the set screw in the crank handle hub with the flat of the gear assembly shaft, slide the crank onto the shaft, then tighten the set screw to secure it in place.
6. Thread the two lock knobs into the holes on the side of the bottom support.
7. Attach the roller bracket to the top vertical support with the four ¼"-20 x ½" flange bolts.
8. Insert one side of the roller axle into a mounting hole on the roller bracket, then push in on the other end of the spring-loaded axle until you can insert it into the remaining mounting hole.

# Parts Breakdown

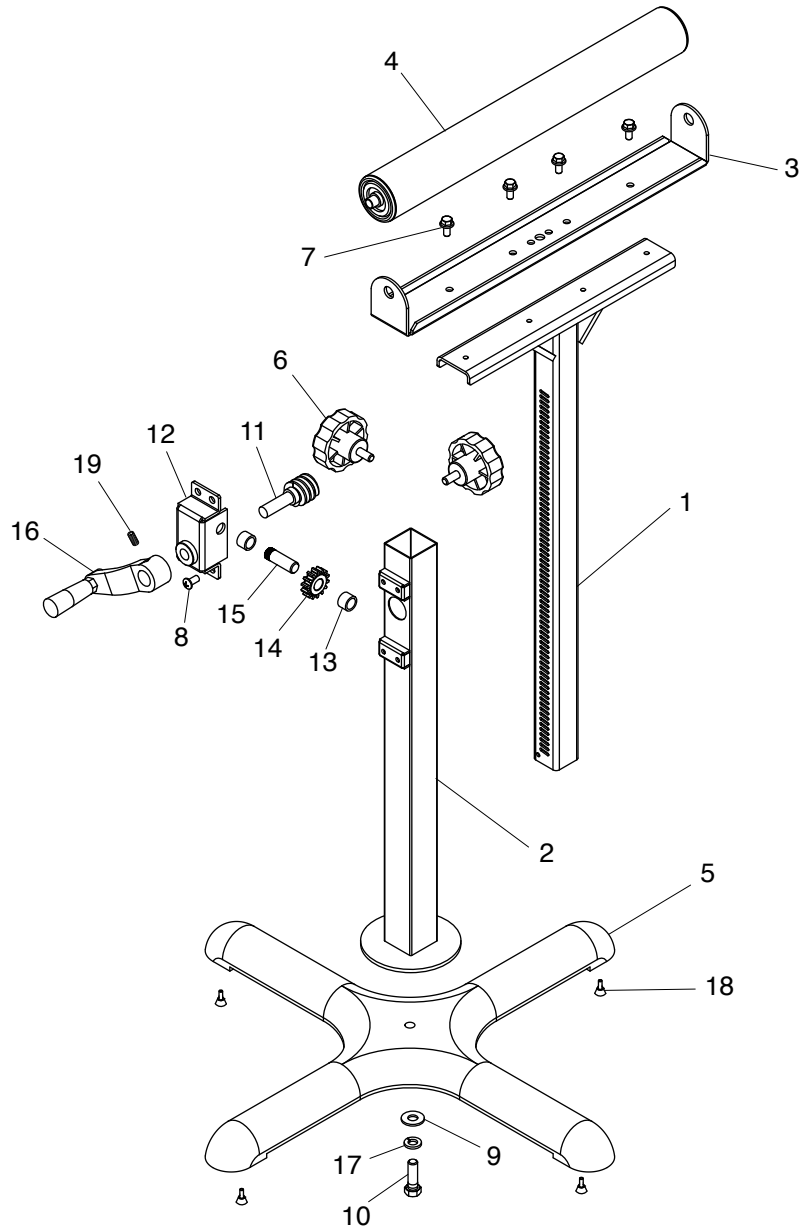

REF PART #	DESCRIPTION	QTY
1	T10114001 TOP VERTICAL SUPPORT	1
2	T10114002 BOTTOM VERTICAL SUPPORT	1
3	T10114003 ROLLER BRACKET	1
4	T10114004 ROLLER ASSEMBLY	1
5	T10114005 BASE	1
6	T10114006 LOCK KNOB 5/16-18 X 3/4	2
7	PFB03 FLANGE BOLT 1/4-20 X 1/2	4
8	PS04 PHLP HD SCR 1/4-20 X 1/2	4
9	PW02 FLAT WASHER 3/8	1
10	PB18 HEX BOLT 3/8-16 X 1	1

REF PART #	DESCRIPTION	QTY
11	T10114011 WORM GEAR	1
12	T10114012 GEAR HOUSING	1
13	T10114013 BUSHING	2
14	T10114014 BEVEL GEAR	1
15	T10114015 GEAR AXLE	1
16	T10114016 CRANK HANDLE	1
17	PLW04 LOCK WASHER 3/8	1
18	T10114018 FOOT PAD M6-1 X 20	4
19	PSS01M SET SCREW M6-1 X 10	1

COPYRIGHT © NOVEMBER, 2008 BY GRIZZLY INDUSTRIAL, INC.  
**WARNING: NO PORTION OF THIS MANUAL MAY BE REPRODUCED IN ANY SHAPE  
 OR FORM WITHOUT THE WRITTEN APPROVAL OF GRIZZLY INDUSTRIAL, INC.**  
 #TS11343 PRINTED IN TAIWAN