

Grizzly *Industrial, Inc.*®

MODEL G1015 KNIFE BLADE SANDER/BUFFER OWNER'S MANUAL *(For models manufactured since 10/24)*



COPYRIGHT © OCTOBER, 1999 BY GRIZZLY INDUSTRIAL, INC., REVISED OCTOBER, 2024 (LW)
**WARNING: NO PORTION OF THIS MANUAL MAY BE REPRODUCED IN ANY SHAPE
OR FORM WITHOUT THE WRITTEN APPROVAL OF GRIZZLY INDUSTRIAL, INC.**
#TS11937 PRINTED IN TAIWAN

V1.10.24

******Keep for Future Reference******

 **WARNING!**

This manual provides critical safety instructions on the proper setup, operation, maintenance, and service of this machine/tool. Save this document, refer to it often, and use it to instruct other operators.

Failure to read, understand and follow the instructions in this manual may result in fire or serious personal injury—including amputation, electrocution, or death.

The owner of this machine/tool is solely responsible for its safe use. This responsibility includes but is not limited to proper installation in a safe environment, personnel training and usage authorization, proper inspection and maintenance, manual availability and comprehension, application of safety devices, cutting/sanding/grinding tool integrity, and the usage of personal protective equipment.

The manufacturer will not be held liable for injury or property damage from negligence, improper training, machine modifications or misuse.

 **WARNING!**

Some dust created by power sanding, sawing, grinding, drilling, and other construction activities contains chemicals known to the State of California to cause cancer, birth defects or other reproductive harm. Some examples of these chemicals are:

- **Lead from lead-based paints.**
- **Crystalline silica from bricks, cement and other masonry products.**
- **Arsenic and chromium from chemically-treated lumber.**

Your risk from these exposures varies, depending on how often you do this type of work. To reduce your exposure to these chemicals: Work in a well ventilated area, and work with approved safety equipment, such as those dust masks that are specially designed to filter out microscopic particles.

Table of Contents

- INTRODUCTION..... 2**
 - Contact Info.....2
 - Manual Accuracy.....2
 - Identification.....3
 - Machine Data Sheet.....4

- SECTION 1: SAFETY..... 6**
 - Safety Instructions for Machinery.....6
 - Additional Safety for Sander/Buffers.....8

- SECTION 2: POWER SUPPLY..... 9**

- SECTION 3: SETUP.....11**
 - Needed for Setup.....11
 - Unpacking.....11
 - Inventory.....12
 - Cleanup.....13
 - Site Considerations.....14
 - Mounting.....15
 - Assembly.....15
 - Test Run.....18

- SECTION 4: OPERATIONS..... 19**
 - Operation Overview.....19
 - Sanding Belt.....20
 - Belt Sanding.....22
 - Installing Optional 10" Drive Wheel.....23
 - Auxiliary Attachments.....25

- SECTION 5: ACCESSORIES..... 26**

- SECTION 6: MAINTENANCE..... 27**
 - Schedule.....27
 - Cleaning.....27
 - Lubrication.....27

- SECTION 7: SERVICE..... 28**
 - Troubleshooting.....28

- SECTION 8: WIRING..... 29**
 - Wiring Safety Instructions.....29
 - Wiring Diagram.....30

- SECTION 9: PARTS..... 31**
 - Main.....31
 - Sanding Assembly.....32
 - Labels & Cosmetics.....34

- WARRANTY & RETURNS..... 37**

INTRODUCTION

Contact Info

We stand behind our machines! If you have questions or need help, contact us with the information below. Before contacting, make sure you get the **serial number** and **manufacture date** from the machine ID label. This will help us help you faster.

Grizzly Technical Support
1815 W. Battlefield
Springfield, MO 65807
Phone: (570) 546-9663
Email: techsupport@grizzly.com

We want your feedback on this manual. What did you like about it? Where could it be improved? Please take a few minutes to give us feedback.

Grizzly Documentation Manager
P.O. Box 2069
Bellingham, WA 98227-2069
Email: manuals@grizzly.com

CAUTION

No list of safety guidelines can be complete. Every shop environment is different. Always consider safety first, as it applies to your individual working conditions. Use this and other machinery with caution and respect. Failure to do so could result in serious personal injury, damage to equipment, or poor work results.

WARNING

Like all machinery there is potential danger when operating this machine. Accidents are frequently caused by lack of familiarity or failure to pay attention. Use this machine with respect and caution to decrease the risk of operator injury. If normal safety precautions are overlooked or ignored, serious personal injury may occur.

Manual Accuracy

We are proud to provide a high-quality owner's manual with your new machine!

We made every effort to be exact with the instructions, specifications, drawings, and photographs in this manual. Sometimes we make mistakes, but our policy of continuous improvement also means that **sometimes the machine you receive is slightly different than shown in the manual.**

If you find this to be the case, and the difference between the manual and machine leaves you confused or unsure about something, check our website for an updated version. We post current manuals and manual updates for free on our website at www.grizzly.com.

Alternatively, you can call our Technical Support for help. Before calling, make sure you write down the **manufacture date** and **serial number** from the machine ID label (see below). This information is required for us to provide proper tech support, and it helps us determine if updated documentation is available for your machine.

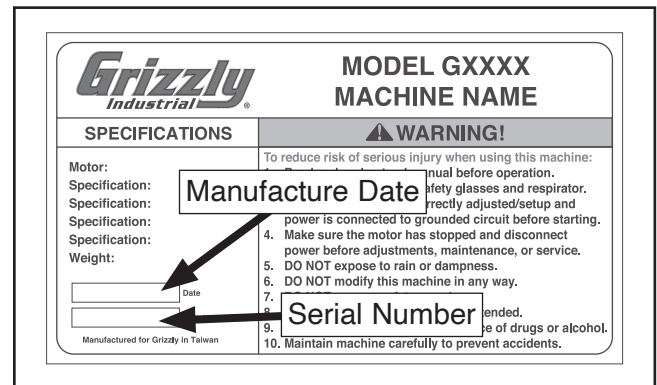

Grizzly Industrial MODEL GXXXX MACHINE NAME

WARNING!

To reduce risk of serious injury when using this machine:

1. Read manual before operation.
2. Wear safety glasses and respirator.
3. Make sure safety is correctly adjusted/setup and power is connected to grounded circuit before starting.
4. Make sure the motor has stopped and disconnect power before adjustments, maintenance, or service.
5. DO NOT expose to rain or dampness.
6. DO NOT modify this machine in any way.
- 7.
- 8.
9. Do not use while under the influence of drugs or alcohol.
10. Maintain machine carefully to prevent accidents.

SPECIFICATIONS

Motor: _____
Specification: _____
Specification: _____
Specification: _____
Weight: _____

Manufacture Date: _____ Date _____
Serial Number: _____ ended.

Manufactured for Grizzly in Taiwan



Identification

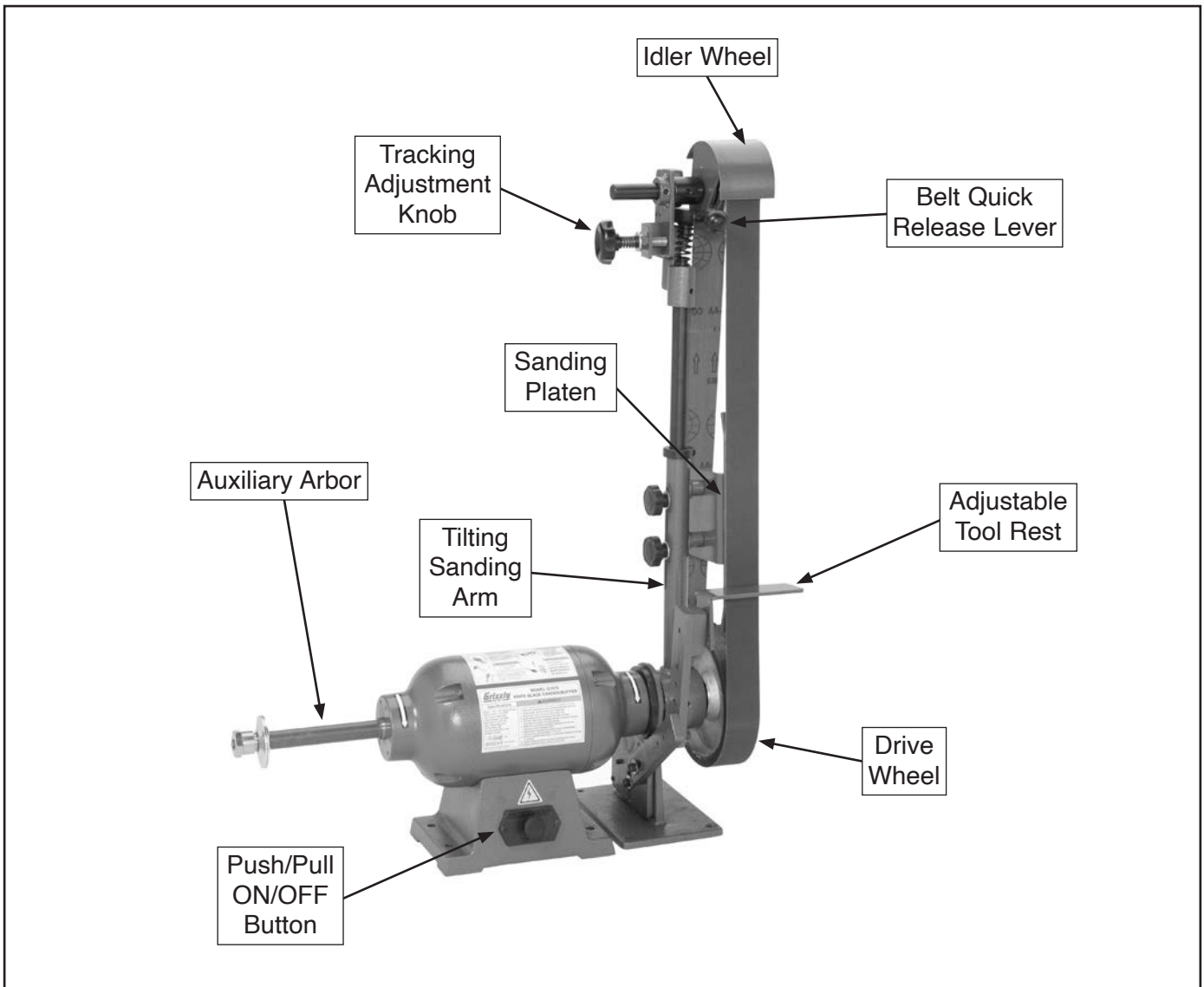

Figure 1. Model G1015 identification.

!WARNING

For Your Own Safety Read Instruction Manual Before Operating

- a) Wear eye protection.
- b) Support workpiece with tool rest.
- c) Maintain $\frac{1}{16}$ in. maximum clearance between tool rest and sanding belt.





MACHINE DATA SHEET

Customer Service #: (570) 546-9663 · To Order Call: (800) 523-4777 · Fax #: (800) 438-5901

MODEL G1015 KNIFE BLADE SANDER/BUFFER

Product Dimensions:

Weight..... 105 lbs.
Width (side-to-side) x Depth (front-to-back) x Height..... 38-3/4 x 29-1/2 x 39 in.
Footprint (Length x Width)..... 10 x 16-1/4 in.

Shipping Dimensions:

Carton #1

Type..... Cardboard Box
Content..... Machine
Weight..... 59 lbs.
Length x Width x Height..... 31 x 17 x 15 in.
Must Ship Upright..... No

Carton #2

Type..... Cardboard Box
Content..... Sanding Arm
Weight..... 56 lbs.
Length x Width x Height..... 27 x 11 x 9 in.
Must Ship Upright..... No

Electrical:

Power Requirement..... 110V, Single-Phase, 60 Hz
Full-Load Current Rating..... 14A
Minimum Circuit Size..... 15A
Connection Type..... Cord & Plug
Power Cord Included..... Yes
Power Cord Length..... 72 in.
Power Cord Gauge..... 16 AWG
Plug Included..... Yes
Included Plug Type..... 5-15
Switch Type..... Push Pull

Motors:

Main

Horsepower..... 1 HP
Phase..... Single-Phase
Amps..... 14A
Speed..... 1725 RPM
Type..... TEFC Capacitor-Start Induction
Power Transfer..... Direct Drive
Bearings..... Shielded & Permanently Lubricated
Centrifugal Switch/Contacts Type..... Internal

Main Specifications:

Mounting Info

Number of Mounting Holes..... 8
Mounting Hole Diameter..... 1/2 in.
Mounting Hole Dimensions, Center-to-Center..... 3-1/4 x 8 (Motor Base), 4-3/4 x 8 (Sander Base) in.



Spindle

Spindle Speed..... 1725 RPM
Spindle Diameter..... 5/8 in.

Belt Sander Info

Sanding Belt Width..... 2 in.
Sanding Belt Length..... 72 - 76 in.
Sanding Belt Speed..... 3600 FPM
Sanding Belt Tilt..... 0 - 90 deg.
Max Height of Belt in Vertical Position..... 39 in.
Drive Wheel Diameter..... 8 in.
Drive Wheel Width..... 2 in.
Belt Tension Release Type..... Quick Release
Platen Type..... Graphite Coated
Platen Length..... 9-1/4 in.
Platen Width..... 1-7/8 in.
Idler Wheel Diameter..... 4 in.
Idler Wheel Width..... 2 in.

Construction

Base..... Cast Iron
Stand..... Cast Iron
Paint/Finish..... Epoxy

Other Specifications:

Country of Origin Taiwan
Warranty 1 Year
Approximate Assembly & Setup Time 1 Hour
Serial Number Location ID Label
ISO 9001 Factory Yes

Features:

Belt Arm Can Be Fully Tilted
Auxiliary Arbor Accepts Buffing Wheels, Sanding Drums, or Flap Wheels
Rubber Drive Roller



SECTION 1: SAFETY

For Your Own Safety, Read Instruction Manual Before Operating This Machine

The purpose of safety symbols is to attract your attention to possible hazardous conditions. This manual uses a series of symbols and signal words intended to convey the level of importance of the safety messages. The progression of symbols is described below. Remember that safety messages by themselves do not eliminate danger and are not a substitute for proper accident prevention measures. Always use common sense and good judgment.



Indicates an imminently hazardous situation which, if not avoided, **WILL** result in death or serious injury.



Indicates a potentially hazardous situation which, if not avoided, **COULD** result in death or serious injury.



Indicates a potentially hazardous situation which, if not avoided, **MAY** result in minor or moderate injury. It may also be used to alert against unsafe practices.

NOTICE

Alerts the user to useful information about proper operation of the machine to avoid machine damage.

Safety Instructions for Machinery



OWNER'S MANUAL. Read and understand this owner's manual **BEFORE** using machine.

TRAINED OPERATORS ONLY. Untrained operators have a higher risk of being hurt or killed. Only allow trained/supervised people to use this machine. When machine is not being used, disconnect power, remove switch keys, or lock-out machine to prevent unauthorized use—especially around children. Make your workshop kid proof!

DANGEROUS ENVIRONMENTS. Do not use machinery in areas that are wet, cluttered, or have poor lighting. Operating machinery in these areas greatly increases the risk of accidents and injury.

MENTAL ALERTNESS REQUIRED. Full mental alertness is required for safe operation of machinery. Never operate under the influence of drugs or alcohol, when tired, or when distracted.

ELECTRICAL EQUIPMENT INJURY RISKS.

You can be shocked, burned, or killed by touching live electrical components or improperly grounded machinery. To reduce this risk, only allow qualified service personnel to do electrical installation or repair work, and always disconnect power before accessing or exposing electrical equipment.

DISCONNECT POWER FIRST. Always disconnect machine from power supply **BEFORE** making adjustments, changing tooling, or servicing machine. This prevents an injury risk from unintended startup or contact with live electrical components.

EYE PROTECTION. Always wear ANSI-approved safety glasses or a face shield when operating or observing machinery to reduce the risk of eye injury or blindness from flying particles. Everyday eyeglasses are **NOT** approved safety glasses.



WARNING

WEARING PROPER APPAREL. Do not wear loose clothing, gloves, neckties, or jewelry that can become entangled in moving parts. Always tie back or cover long hair. Wear non-slip footwear to reduce risk of slipping and losing control or accidentally contacting cutting tool or moving parts.

HAZARDOUS DUST. Dust created by machinery operations may cause cancer, birth defects, or long-term respiratory damage. Be aware of dust hazards associated with each workpiece material. Always wear a NIOSH-approved respirator to reduce your risk.

HEARING PROTECTION. Always wear hearing protection when operating or observing loud machinery. Extended exposure to this noise without hearing protection can cause permanent hearing loss.

REMOVE ADJUSTING TOOLS. Tools left on machinery can become dangerous projectiles upon startup. Never leave chuck keys, wrenches, or any other tools on machine. Always verify removal before starting!

USE CORRECT TOOL FOR THE JOB. Only use this tool for its intended purpose—do not force it or an attachment to do a job for which it was not designed. Never make unapproved modifications—modifying tool or using it differently than intended may result in malfunction or mechanical failure that can lead to personal injury or death!

AWKWARD POSITIONS. Keep proper footing and balance at all times when operating machine. Do not overreach! Avoid awkward hand positions that make workpiece control difficult or increase the risk of accidental injury.

CHILDREN & BYSTANDERS. Keep children and bystanders at a safe distance from the work area. Stop using machine if they become a distraction.

GUARDS & COVERS. Guards and covers reduce accidental contact with moving parts or flying debris. Make sure they are properly installed, undamaged, and working correctly BEFORE operating machine.

FORCING MACHINERY. Do not force machine. It will do the job safer and better at the rate for which it was designed.

NEVER STAND ON MACHINE. Serious injury may occur if machine is tipped or if the cutting tool is unintentionally contacted.

STABLE MACHINE. Unexpected movement during operation greatly increases risk of injury or loss of control. Before starting, verify machine is stable and mobile base (if used) is locked.

USE RECOMMENDED ACCESSORIES. Consult this owner's manual or the manufacturer for recommended accessories. Using improper accessories will increase the risk of serious injury.

UNATTENDED OPERATION. To reduce the risk of accidental injury, turn machine **OFF** and ensure all moving parts completely stop before walking away. Never leave machine running while unattended.

MAINTAIN WITH CARE. Follow all maintenance instructions and lubrication schedules to keep machine in good working condition. A machine that is improperly maintained could malfunction, leading to serious personal injury or death.

DAMAGED PARTS. Regularly inspect machine for damaged, loose, or mis-adjusted parts—or any condition that could affect safe operation. Immediately repair/replace BEFORE operating machine. For your own safety, DO NOT operate machine with damaged parts!

MAINTAIN POWER CORDS. When disconnecting cord-connected machines from power, grab and pull the plug—NOT the cord. Pulling the cord may damage the wires inside. Do not handle cord/plug with wet hands. Avoid cord damage by keeping it away from heated surfaces, high traffic areas, harsh chemicals, and wet/damp locations.

EXPERIENCING DIFFICULTIES. If at any time you experience difficulties performing the intended operation, stop using the machine! Contact our Technical Support at (570) 546-9663.



Additional Safety for Sander/Buffers

WARNING

Serious injury or death can occur from fingers, clothing, jewelry, or hair getting entangled in rotating disc, belt, spindle or other moving components. Abrasion injuries can occur from touching moving sandpaper with bare skin. Workpieces thrown by sanding surface can strike operator or bystanders with moderate force, causing impact injuries. Long-term respiratory damage can occur from using sander without proper use of a respirator. To reduce the risk of these hazards, operator or bystanders **MUST** completely heed the hazards and warnings below.

SANDPAPER DIRECTION. Feeding workpiece incorrectly can cause it to be thrown from machine, striking operator or bystanders, or causing your hands to slip into the moving sandpaper. To reduce these risks, only sand against direction of sandpaper travel, ensure workpiece is properly supported, and avoid introducing sharp edges into moving sandpaper on the leading side of the workpiece.

HAND PLACEMENT. Rotating sandpaper can remove a large amount of flesh quickly. Always keep hands away from sandpaper during operation. Never touch moving sandpaper on purpose. Use a brush to clean table of sawdust and chips.

FEEDING WORKPIECE. Forcefully jamming workpiece into sanding surface could cause it to be grabbed aggressively, pulling hands into sanding surface. Firmly grasp workpiece in both hands and ease it into sandpaper using light pressure.

AVOIDING ENTANGLEMENT. Becoming entangled in moving parts can cause pinching and crushing injuries. To avoid these hazards, keep all guards in place and closed. **DO NOT** wear loose clothing, gloves, or jewelry, and tie back long hair.

WORKPIECE SUPPORT. Workpiece kickback can occur with violent force if workpiece is not properly supported during operation. Always sand with workpiece firmly against table or another support device.

SANDING DUST. Sanding creates large amounts of dust that can lead to eye injury or respiratory illness. Reduce your risk by always wearing approved eye and respiratory protection when using sander. Never operate without adequate dust collection system in place and running. However, dust collection is not a substitute for using a respirator.

WORKPIECE INSPECTION. Nails, staples, knots, or other imperfections in workpiece can be dislodged and thrown from sander at a high rate of speed at people, or cause damage to sandpaper or sander. Never sand stock that has embedded foreign objects or questionable imperfections.

SANDPAPER CONDITION. Worn or damaged sandpaper can fly apart and throw debris at operator, or aggressively grab workpiece, resulting in subsequent injuries from operator loss of workpiece control. Always inspect sandpaper before operation and replace if worn or damaged.

IN-RUNNING NIP POINTS. The gap between moving sandpaper and fixed table/support creates a pinch point for fingers or workpieces; the larger this gap is, the greater the risk of fingers or workpieces getting caught in it. Minimize this risk by adjusting table/support to no more than $\frac{1}{16}$ " away from sandpaper. For spindle sanders, always use the table insert that fits closest diameter of installed drum.

MINIMUM STOCK DIMENSION. Small workpieces can be aggressively pulled from your hands, causing contact with sanding surface. Always use a jig or other holding device when sanding small workpieces, and keep hands and fingers at least 2" away from sanding surface.

WORKPIECE INTEGRITY. Sanding fragile workpieces can result in loss of control, resulting in abrasion injuries, impact injuries, or damage to sandpaper. Only sand solid workpieces that can withstand power sanding forces. Make sure workpiece shape is properly supported; avoid sanding workpieces without flat bottom surfaces unless some type of jig is used to maintain support and control when sanding force is applied.



SECTION 2: POWER SUPPLY

Availability

Before installing the machine, consider the availability and proximity of the required power supply circuit. If an existing circuit does not meet the requirements for this machine, a new circuit must be installed. To minimize the risk of electrocution, fire, or equipment damage, installation work and electrical wiring must be done by an electrician or qualified service personnel in accordance with all applicable codes and standards.

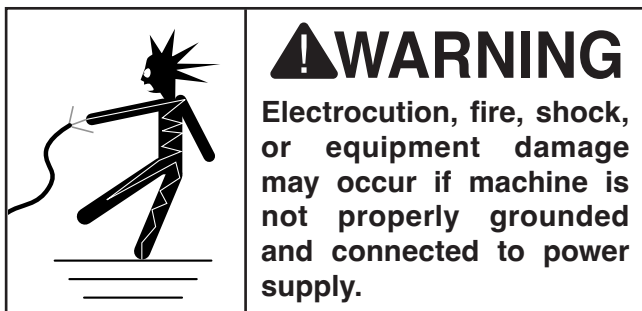

Full-Load Current Rating

The full-load current rating is the amperage a machine draws at 100% of the rated output power. On machines with multiple motors, this is the amperage drawn by the largest motor or sum of all motors and electrical devices that might operate at one time during normal operations.

Full-Load Current Rating at 110V 14 Amps

The full-load current is not the maximum amount of amps that the machine will draw. If the machine is overloaded, it will draw additional amps beyond the full-load rating.

If the machine is overloaded for a sufficient length of time, damage, overheating, or fire may result—especially if connected to an undersized circuit. To reduce the risk of these hazards, avoid overloading the machine during operation and make sure it is connected to a power supply circuit that meets the specified circuit requirements.

! WARNING

Serious injury could occur if you connect machine to power before completing setup process. DO NOT connect to power until instructed later in this manual.

110V Circuit Requirements

This machine is prewired to operate on a power supply circuit that has a verified ground and meets the following requirements:

Nominal Voltage 110V, 115V, 120V
Cycle 60 Hz
Phase Single-Phase
Power Supply Circuit 15 Amps

A power supply circuit includes all electrical equipment between the breaker box or fuse panel in the building and the machine. The power supply circuit used for this machine must be sized to safely handle the full-load current drawn from the machine for an extended period of time. (If this machine is connected to a circuit protected by fuses, use a time delay fuse marked D.)

! CAUTION

For your own safety and protection of property, consult an electrician if you are unsure about wiring practices or electrical codes in your area.

Note: *Circuit requirements in this manual apply to a dedicated circuit—where only one machine will be running on the circuit at a time. If machine will be connected to a shared circuit where multiple machines may be running at the same time, consult an electrician or qualified service personnel to ensure circuit is properly sized for safe operation.*



Grounding & Plug Requirements

This machine **MUST** be grounded. In the event of certain malfunctions or breakdowns, grounding reduces the risk of electric shock by providing a path of least resistance for electric current.

This machine is equipped with a power cord that has an equipment-grounding wire and a grounding plug. Only insert plug into a matching receptacle (outlet) that is properly installed and grounded in accordance with all local codes and ordinances. **DO NOT** modify the provided plug!

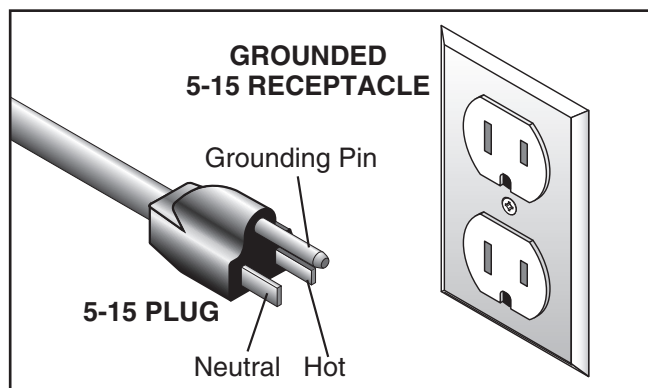
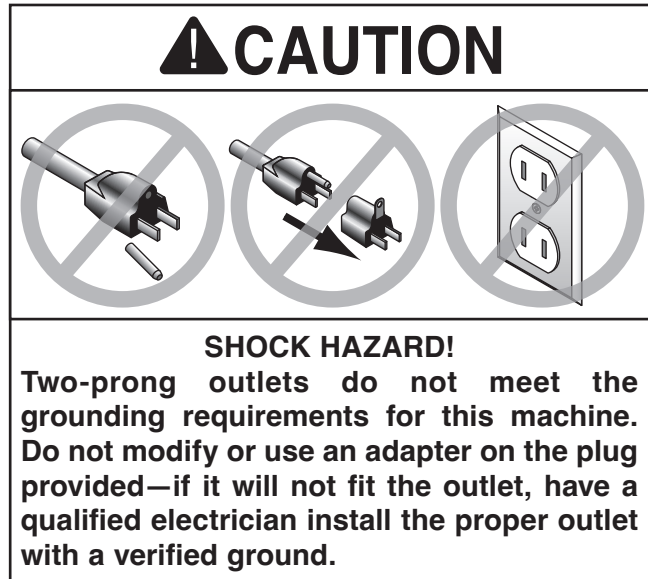

Figure 2. Typical 5-15 plug and receptacle.



Improper connection of the equipment-grounding wire can result in a risk of electric shock. The wire with green insulation (with or without yellow stripes) is the equipment-grounding wire. If repair or replacement of the power cord or plug is necessary, do not connect the equipment-grounding wire to a live (current carrying) terminal.

Check with a qualified electrician or service personnel if you do not understand these grounding requirements, or if you are in doubt about whether the tool is properly grounded. If you ever notice that a cord or plug is damaged or worn, disconnect it from power, and immediately replace it with a new one.

Extension Cords

We do not recommend using an extension cord with this machine. If you must use an extension cord, only use it if absolutely necessary and only on a temporary basis.

Extension cords cause voltage drop, which can damage electrical components and shorten motor life. Voltage drop increases as the extension cord size gets longer and the gauge size gets smaller (higher gauge numbers indicate smaller sizes).

Any extension cord used with this machine must be in good condition and contain a ground wire and matching plug/receptacle. Additionally, it must meet the following size requirements:

Minimum Gauge Size 14 AWG
Maximum Length (Shorter is Better).....50 ft.



SECTION 3: SETUP

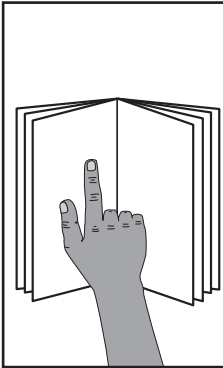

!WARNING

This machine presents serious injury hazards to untrained users. Read through this entire manual to become familiar with the controls and operations before starting the machine!

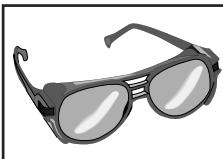

!WARNING

Wear safety glasses during the entire setup process!

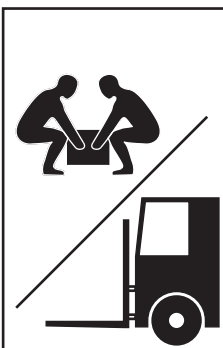

!WARNING

HEAVY LIFT!

Straining or crushing injury may occur from improperly lifting machine or some of its parts. To reduce this risk, get help from other people and use a forklift (or other lifting equipment) rated for weight of this machine.

Needed for Setup

The following are needed to complete the setup process, but are not included with your machine.

Description	Qty
• Safety Glasses	1
• Cleaner/Degreaser (Page 13)	As Needed
• Disposable Shop Rags.....	As Needed
• Hex Wrench 4mm.....	1
• Hex Wrench 5mm.....	1
• Hex Wrench 6mm.....	1
• Dead-Blow Hammer	1
• Mounting Hardware (Page 15) ...	As Needed

Unpacking

This machine was carefully packaged for safe transport. When unpacking, separate all enclosed items from packaging materials and inspect them for shipping damage. ***If items are damaged, please call us immediately at (570) 546-9663.***

IMPORTANT: Save all packaging materials until you are completely satisfied with the machine and have resolved any issues between Grizzly or the shipping agent. ***You MUST have the original packaging to file a freight claim. It is also extremely helpful if you need to return your machine later.***



Inventory

The following is a list of items shipped with your machine. Before beginning setup, lay these items out and inventory them.

If any non-proprietary parts are missing (e.g. a nut or a washer), we will gladly replace them; or for the sake of expediency, replacements can be obtained at your local hardware store.

J.	Auxiliary Arbor Flanges	2
K.	Auxiliary Arbor Flanges & Nut $\frac{5}{8}$ "-18	1
L.	Pivot Arm Bracket.....	1
M.	Pivot Arm.....	1
N.	Drive Wheel.....	1
O.	Tool Rest Support Assembly.....	1
P.	Tool Rest	1
Q.	Platen Bracket	1
R.	Sanding Platen	1

Inventory (Figure 3)	Qty
A. Motor Assembly.....	1
B. Sanding Belt 2" x 72", 100G.....	1
C. Pivot Arm Mounting Bracket.....	1
D. Sanding Arm Assembly.....	1
E. Quick Release Lever Knob	1
F. Cap Screws $\frac{1}{4}$ "-20 x $\frac{1}{2}$ ".....	6
G. Mounting Adapter	1
H. Drive Wheel Flanges.....	2
I. Drive Wheel Arbor Hex Nut $\frac{3}{4}$ "-16.....	1

NOTICE

If you cannot find an item on this list, carefully check around/inside the machine and packaging materials. Often, these items get lost in packaging materials while unpacking or they are pre-installed at the factory.

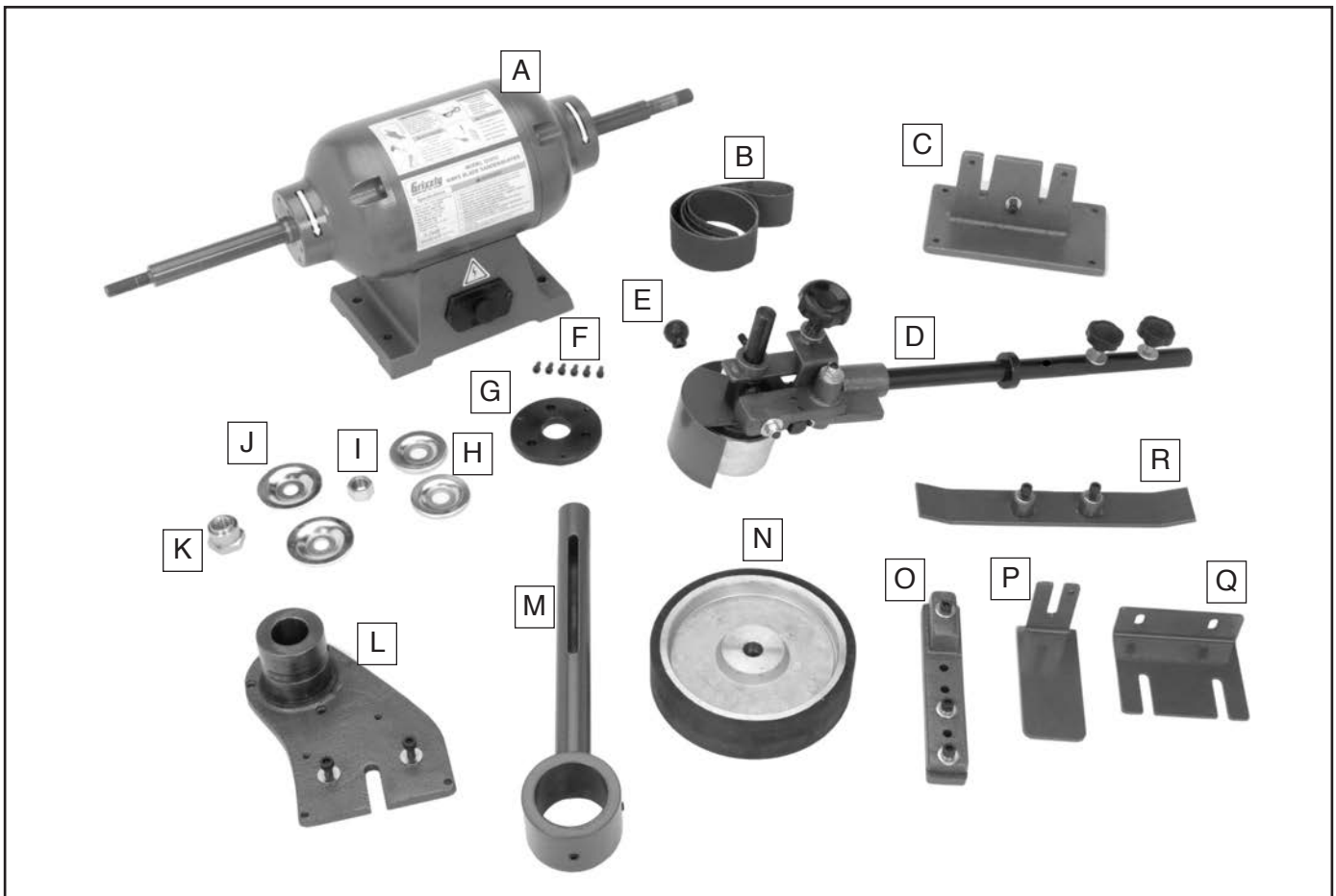

Figure 3. Model G1015 inventory.



Cleanup

The unpainted surfaces of your machine are coated with a heavy-duty rust preventative that prevents corrosion during shipment and storage. This rust preventative works extremely well, but it will take a little time to clean.

Be patient and do a thorough job cleaning your machine. The time you spend doing this now will give you a better appreciation for the proper care of your machine's unpainted surfaces.

There are many ways to remove this rust preventative, but the following steps work well in a wide variety of situations. Always follow the manufacturer's instructions with any cleaning product you use and make sure you work in a well-ventilated area to minimize exposure to toxic fumes.

Before cleaning, gather the following:

- Disposable rags
- Cleaner/degreaser (WD-40 works well)
- Safety glasses & disposable gloves
- Plastic paint scraper (optional)

Basic steps for removing rust preventative:

1. Put on safety glasses.
2. Coat rust preventative on the motor assembly and sanding arm assembly shafts (see **Figure 4**) with a liberal amount of cleaner/degreaser, then let it soak for 5–10 minutes.

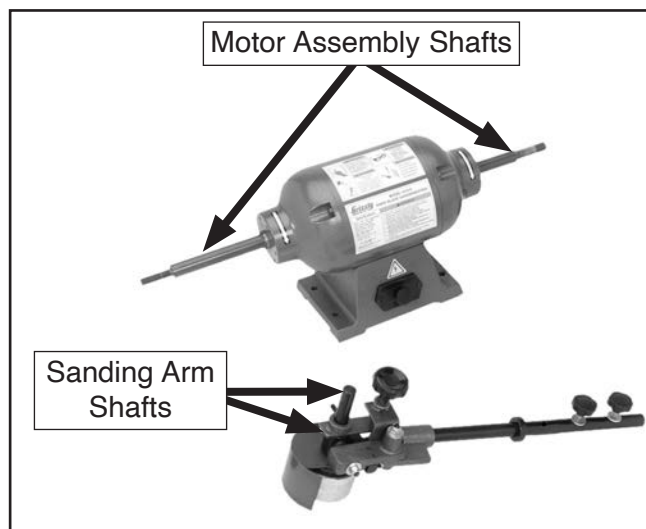
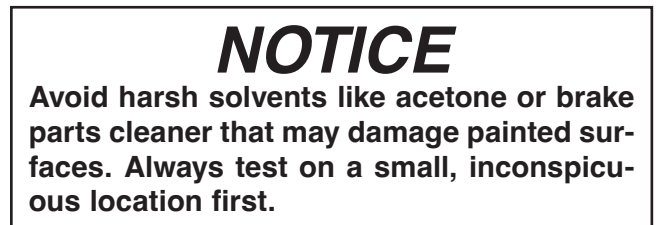
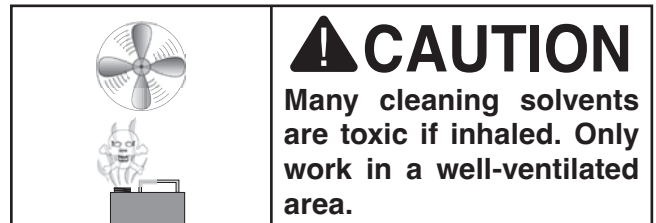
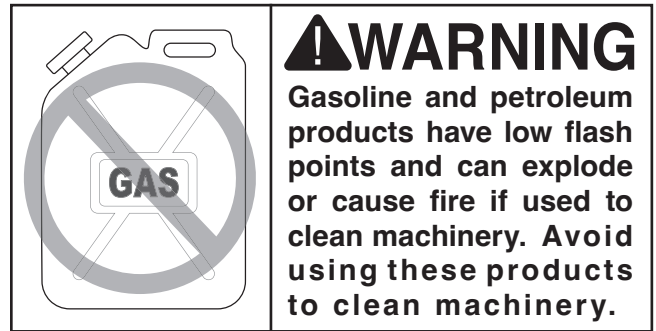

Figure 4. Location of surfaces requiring cleaning.



3. Wipe off the surfaces. If your cleaner/degreaser is effective, the rust preventative will wipe off easily. If you have a plastic paint scraper, scrape off as much as you can first, then wipe off the rest with the rag.
4. Repeat **Steps 2–3** as necessary until clean, then coat all unpainted surfaces with a quality metal protectant to prevent rust.



Site Considerations

Weight Load

Refer to the **Machine Data Sheet** for the weight of your machine. Make sure that the surface upon which the machine is placed will bear the weight of the machine, additional equipment that may be installed on the machine, and the heaviest workpiece that will be used. Additionally, consider the weight of the operator and any dynamic loading that may occur when operating the machine.

Space Allocation

Consider the largest size of workpiece that will be processed through this machine and provide enough space around the machine for adequate operator material handling or the installation of auxiliary equipment. With permanent installations, leave enough space around the machine to open or remove doors/covers as required by the maintenance and service described in this manual. **See below for required space allocation.**

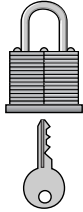
	<p>CAUTION</p> <p>Children or untrained people may be seriously injured by this machine. Only install in an access restricted location.</p>
---	--

Physical Environment

The physical environment where the machine is operated is important for safe operation and longevity of machine components. For best results, operate this machine in a dry environment that is free from excessive moisture, hazardous chemicals, airborne abrasives, or extreme conditions. Extreme conditions for this type of machinery are generally those where the ambient temperature range exceeds 41°–104°F; the relative humidity range exceeds 20%–95% (non-condensing); or the environment is subject to vibration, shocks, or bumps.

Electrical Installation

Place this machine near an existing power source. Make sure all power cords are protected from traffic, material handling, moisture, chemicals, or other hazards. Make sure to leave enough space around machine to disconnect power supply or apply a lockout/tagout device, if required.

Lighting

Lighting around the machine must be adequate enough that operations can be performed safely. Shadows, glare, or strobe effects that may distract or impede the operator must be eliminated.

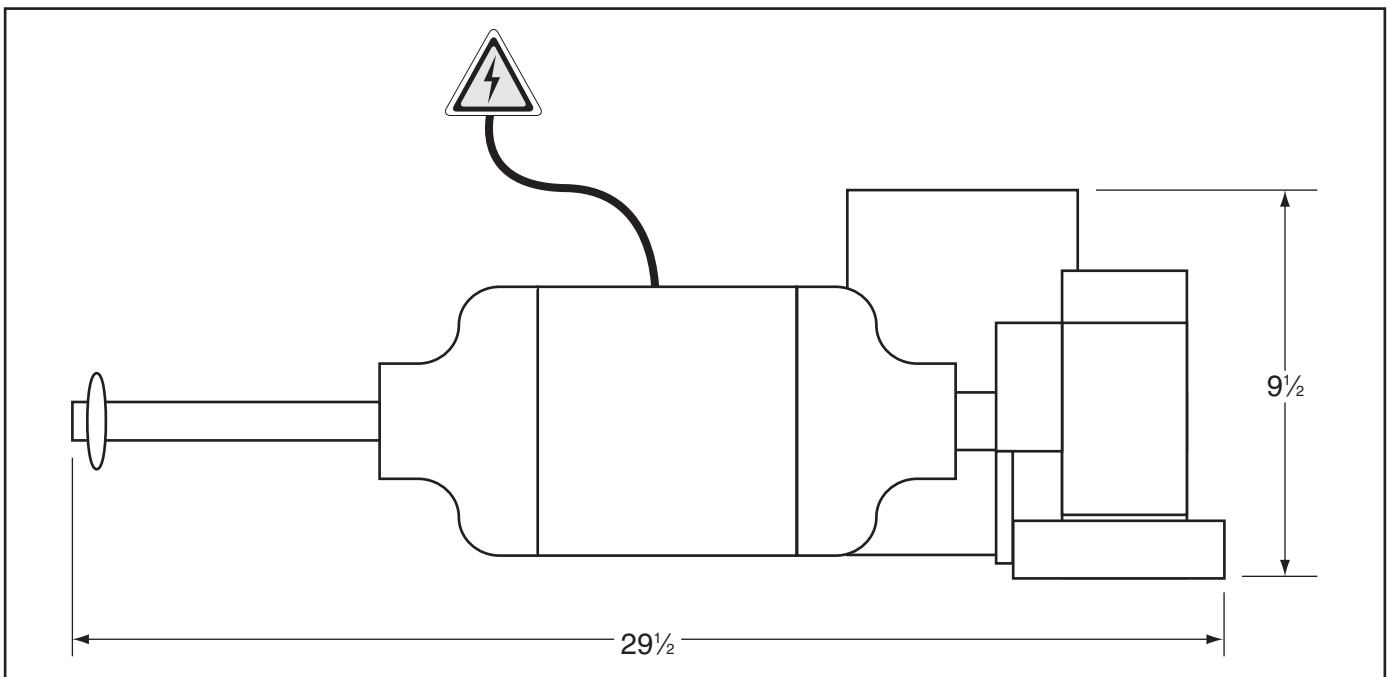

Figure 5. Minimum working clearances.



Mounting

The Model G1015 is a top-heavy machine. Pressure applied to the sanding arm during operation could easily tip the machine over, causing personal injury or property damage. To prevent this, you must firmly mount this machine to a flat, stable surface, such as a workbench, before beginning operations.

Note: During assembly, the position of the sanding arm bracket will change in relation to the motor assembly. **DO NOT** mount the machine to a surface until instructed to in the setup procedure.

The base of the motor assembly and the sanding arm bracket have eight holes for mounting the machine to a workbench. The strongest mounting option is a "Through Mount," where holes are drilled all the way through the workbench, and hex bolts, washers, and hex nuts are used to secure the machine to the workbench.

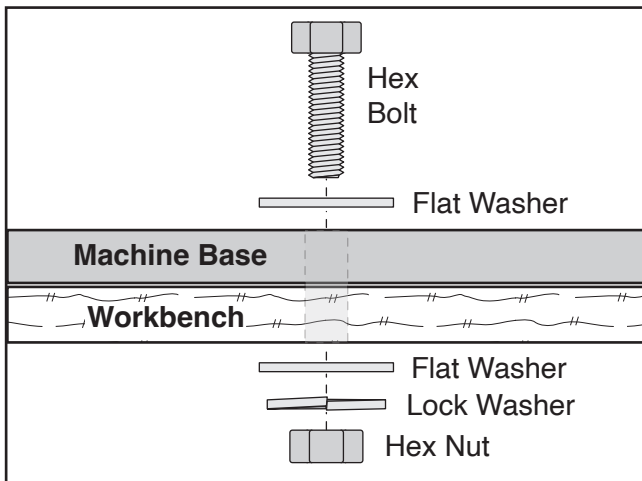

Figure 6. Example of a through mount setup.

!WARNING

This machine is top heavy and could easily tip over during operation and cause serious personal injury or property damage. You **MUST** firmly mount the machine to a level, stable surface before connecting it to power.

Another option for mounting is a "Direct Mount" where the machine is simply secured to the workbench with a lag screw.

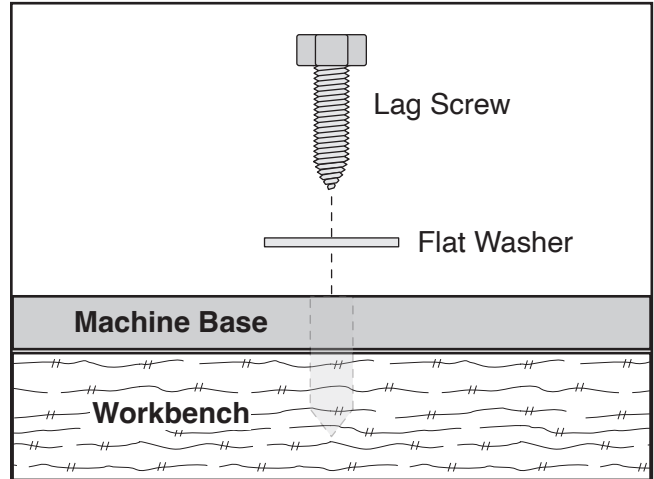

Figure 7. Example of a direct mount setup.

Assembly

To assemble this machine:

1. Slide the mounting adapter onto the right-hand arbor of the motor assembly with the countersunk holes facing out, then rotate it so that the flat edge is at the 10 o'clock position, as shown in **Figure 8**.

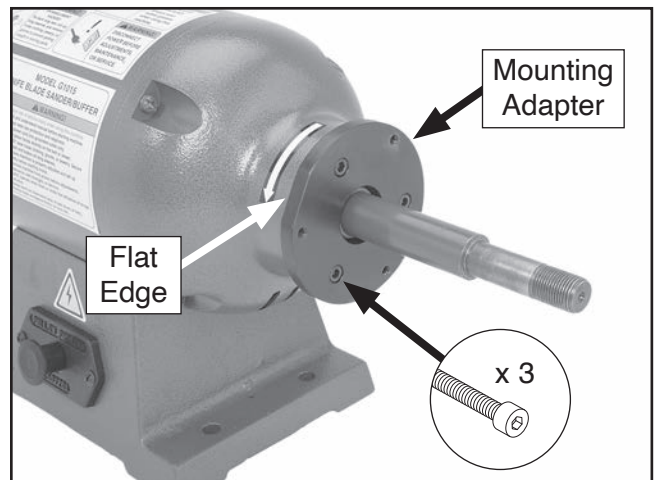

Figure 8. Mounting adapter installed.

2. Secure the adapter to the motor assembly with (3) 1/4"-20 x 1/2" cap screws.



3. Back out the cap screws and set screws in the pivot arm mounting bracket and the pivot arm bracket, then slide the arm bracket onto the mounting bracket, as shown in **Figures 9–10**.

Note: The pivot arm bracket bushing is shipped with a lubricating grease coating on its outside surface. This lubricant will keep the motion of the pivot arm smooth during operation and reduce the wear on the metal-to-metal surfaces.

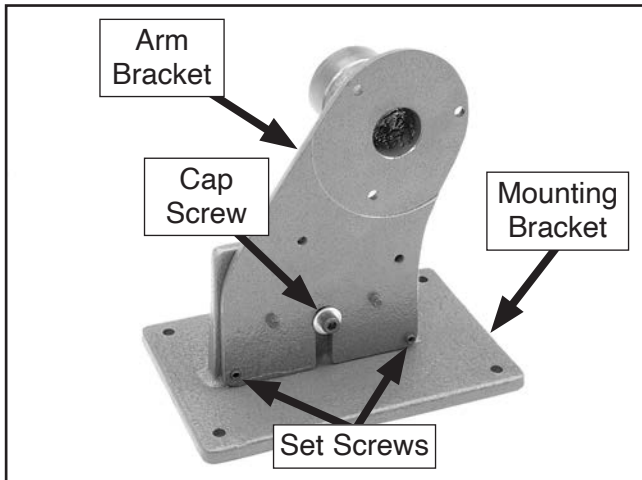

Figure 9. Left side of pivot arm bracket assembly.

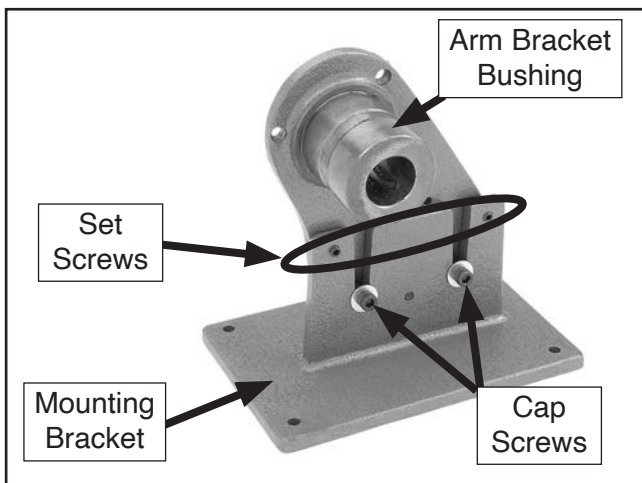

Figure 10. Right side of pivot arm bracket assembly.

4. For now, finger-tighten the three cap screws enough to hold the parts together. You will fully tighten these fasteners in a later step.

Note: Make sure the four set screws do not make contact with the other part of the assembly.

5. Slide the arm bracket assembly onto the right-hand arbor with the arm bracket bushing facing out, as shown in **Figure 11**, then secure it with the remaining (3) 1/4"-20 x 1/2" cap screws.

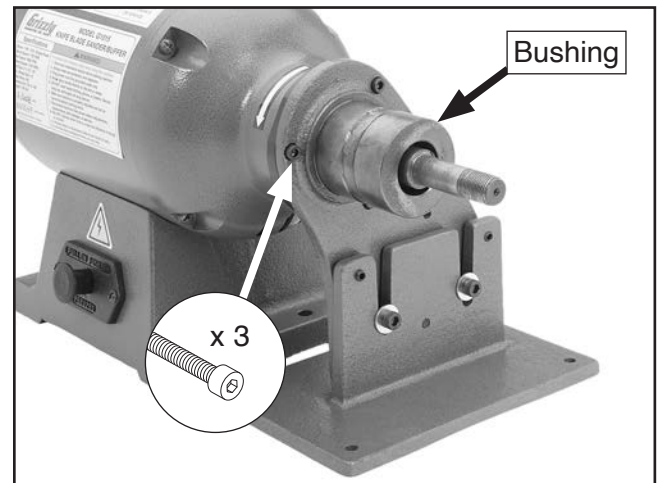

Figure 11. Arm bracket assembly installed onto the motor assembly.

6. Move the machine to the selected mounting surface, and use the eight holes in the base of the motor assembly and the arm bracket assembly as a template for drilling the mounting holes.
7. Loosen the three cap screws of the pivot arm bracket assembly (see **Figures 9–10**), then use the mounting hardware you have chosen to firmly secure the motor assembly and the bracket assembly in place.

Note: Before fully tightening the mounting hardware, make sure that the three cap screws and four set screws of the arm bracket assembly are loose. This will allow the mounting bracket to lay flat on the mounting surface.

8. Tighten the four set screws in the arm bracket assembly (see **Figures 9–10**) just until you feel resistance. This will keep the two parts of the assembly stable during operation.
9. Fully tighten the three cap screws on the arm bracket assembly.



- Back out the two set screws in the round housing of the pivot arm, slide the arm onto the bracket bushing so that the platen bracket cap screws are facing to the right, as shown in **Figure 12**, then tighten the set screws to hold the pivot arm in place.

Note: The pivot arm and bushing are designed so that the set screws tighten into the grooved surface of the bushing. This keeps the pivot arm from sliding off the bushing when using the tilt feature.

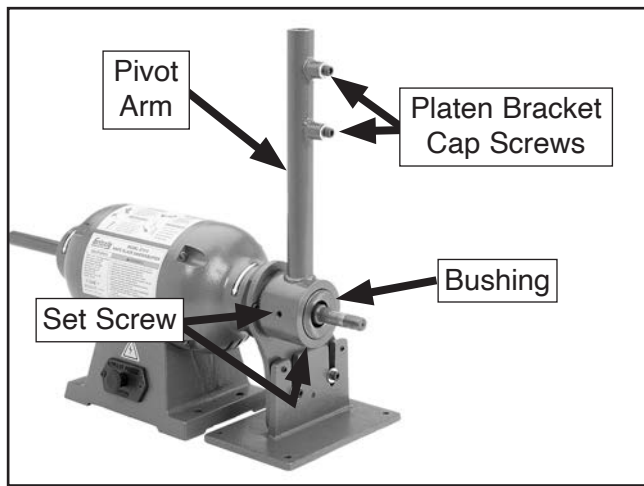

Figure 12. Pivot arm installed.

- Slide the drive wheel onto the right-hand arbor with a drive wheel flange ($\frac{3}{4}$ " center bore) on each side, then secure it in place with the remaining $\frac{3}{4}$ "-16 arbor hex nut (see **Figure 13**).

Note: It may be necessary to use a dead-blow hammer to seat the drive wheel onto the arbor. Take great care not to damage the drive wheel or the threads of the arbor.

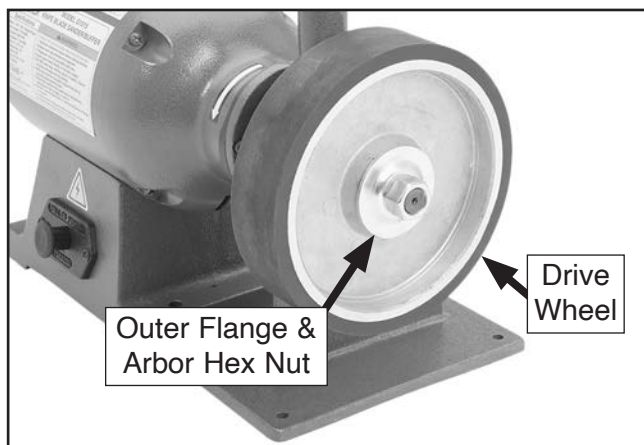

Figure 13. Drive wheel installed.

- Remove the two threaded knobs and flat washers from the sanding arm assembly, insert the shaft into the pivot arm tube until the lock collar rests on top of the tube, as shown in **Figure 14**, then re-install the knobs and flat washers to hold it in place.

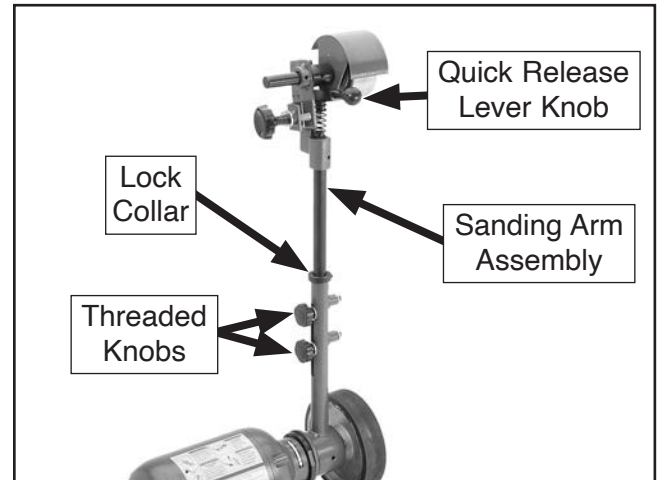

Figure 14. Sanding arm assembly installed.

- Install the quick release lever knob as shown in **Figure 14**.
- Install the platen bracket onto the pivot arm with the pre-installed hardware, as shown in **Figure 15**.

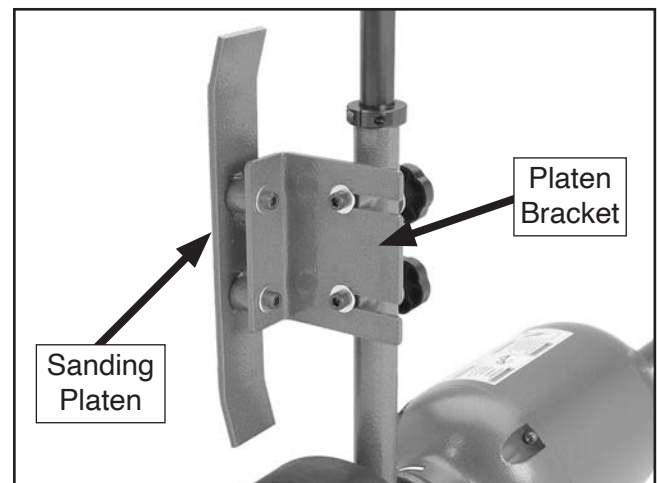

Figure 15. Sanding platen and bracket installed.

- Install the sanding platen onto the platen bracket with the pre-installed hardware, as shown in **Figure 15**.



16. Remove the three cap screws and flat washers that hold the two pieces of the tool rest support assembly together.
17. Mount the first tool rest support that is flat on both sides to the back of the arm bracket with the $\frac{5}{16}$ "-18 x $\frac{3}{4}$ " cap screw (the shortest of the three) and flat washer removed in **Step 16**, as shown in **Figure 16**.

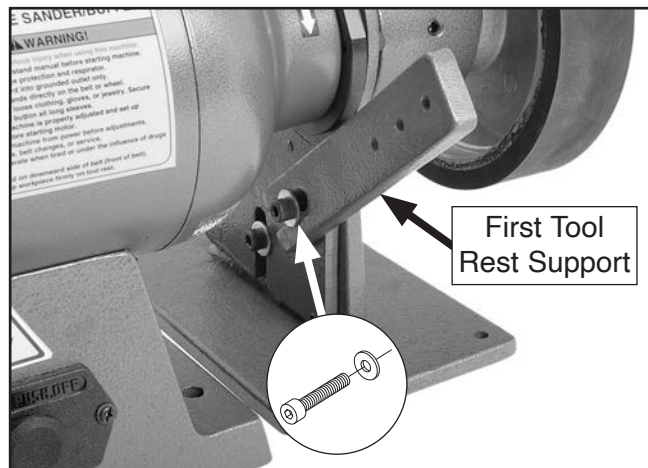

Figure 16. First tool rest bracket installed.

18. Position the second tool rest support so that its flat face is against the first support, then secure it with the (1) $\frac{5}{16}$ "-18 x $1\frac{1}{4}$ " cap screw and flat washer removed in **Step 16**, as shown in **Figure 17**.

Note: *There are several holes provided for attaching the tool rest assembly so that you can choose the best position for your operation.*

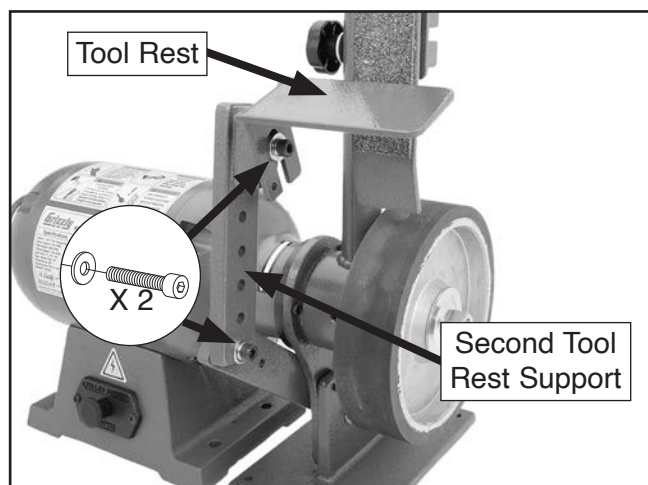

Figure 17. Tool rest installed.

19. Secure the tool rest to the support assembly with the remaining $\frac{5}{16}$ "-18 x $1\frac{1}{4}$ " cap screw and flat washer, as shown in **Figure 17**.

Note: *When the sanding belt is installed and properly tensioned, there should be no more than $\frac{1}{16}$ " between the tool rest and the belt to ensure the workpiece will not get trapped between the rest and belt during operation.*

Test Run

Once the assembly is complete, test run your machine to make sure it runs properly. If, during the test run, you cannot easily locate the source of an unusual noise or vibration, stop using the machine immediately, then review the **Troubleshooting on Page 28**.

If you still cannot remedy a problem, contact our Tech Support at (570) 546-9663 for assistance.

To test run the machine:

1. Make sure you have read the safety instructions at the beginning of the manual and that the machine is set up properly.
2. Make sure all tools and objects used during setup are cleared away from the machine, and that a sanding belt or auxiliary attachment are NOT installed on the machine.
3. Make sure the ON/OFF button is pushed in, then connect the machine to power.
4. Pull the ON/OFF button out to turn the machine **ON**.
5. Listen to and watch for abnormal noises or actions. The machine should run smoothly with little or no vibration or rubbing noises.
 - Strange or unusual noises should be investigated and corrected before operating the machine further. Always disconnect the machine from power when investigating or correcting potential problems.
6. Push the ON/OFF button in to turn the machine **OFF**.



SECTION 4: OPERATIONS

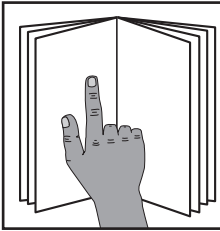

!WARNING

To reduce your risk of serious injury, read this entire manual **BEFORE** using machine.

!WARNING

Eye injuries, respiratory problems, or hearing loss can occur while operating this tool. Wear personal protective equipment to reduce your risk from these hazards.

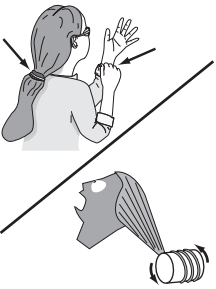
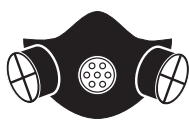

!WARNING

Keep hair, clothing, and jewelry away from moving parts at all times. Entanglement can result in death, amputation, or severe crushing injuries!

NOTICE

If you are not experienced with this type of machine, **WE STRONGLY RECOMMEND** that you seek additional training outside of this manual. Read books/magazines or get formal training before beginning any projects. Regardless of the content in this section, Grizzly Industrial will not be held liable for accidents caused by lack of training.

Operation Overview

The Model G1015 is a versatile machine that can perform a number of different tasks. The following overview gives you the basic process that happens during a sanding operation. Familiarize yourself with this process to better understand the remaining parts of the **Operation** section.

To complete a typical sanding operation, the operator does the following:

1. Examines the workpiece to make sure it is suitable for sanding.
2. Installs the correct sanding belt for the operation (composition and grit).
3. Turns the drive wheel by hand to make sure the sanding belt is tracking correctly and is properly tensioned.
4. Verifies that the platen is centered on the sanding belt.
5. Adjusts the tool rest to the correct position for the operation and makes sure that it is no more than $\frac{1}{16}$ " away from the sanding belt.
6. Connects the machine to power and pulls the ON/OFF button out to turn it **ON**.
7. Verifies that the sanding belt is tracking properly and rotating without interference.
8. Places the workpiece onto the tool rest and slowly moves it into the sanding belt with the direction of the belt.
9. Removes the workpiece and pushes the ON/OFF button in to turn the machine **OFF**.



Sanding Belt

The Model G1015 accepts sanding belts that are 2" wide and 72"–76" in length. The included 72" sanding belt can be installed on either the included 8" drive wheel or the optional Model G9242 10" drive wheel. (Refer to **Installing Optional 10" Drive Wheel** on **Page 23** for more details.) It is not necessary to use a longer sanding belt with the 10" wheel.

To ensure a safe operation and good sanding results, the sanding belt must be properly installed, tensioned, and tracked.

Installing Sanding Belt

1. DISCONNECT MACHINE FROM POWER!
2. With the direction arrows printed on the inside front of the belt facing down, pull down on the quick release lever and wrap the belt around idler and drive wheels so that it is centered on both, as shown in **Figure 18**, then release the lever.

Note: To prevent the belt seam from catching on the workpiece, install the belt so that the direction arrows printed on the inside face of the belt follow the belt rotation, as shown in **Figure 18**.

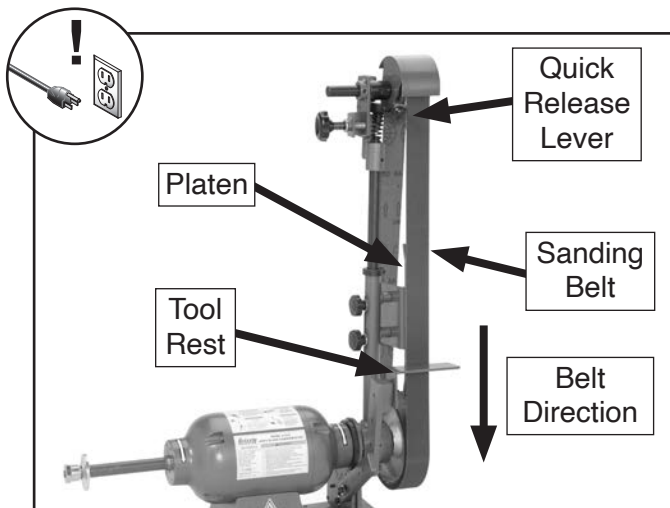

Figure 18. Sanding belt installed.

3. Adjust the platen so that it is centered behind the belt.

4. If needed for your operation, adjust the tool rest position as required. Make sure that it is no more than 1/16" away from the sanding belt to prevent the workpiece being trapped between the tool rest and belt.

Tensioning Sanding Belt

The sanding belt is properly tensioned when there is approximately 1/2" deflection with slight pressure applied to the back loop of the belt, as shown in **Figure 19**.

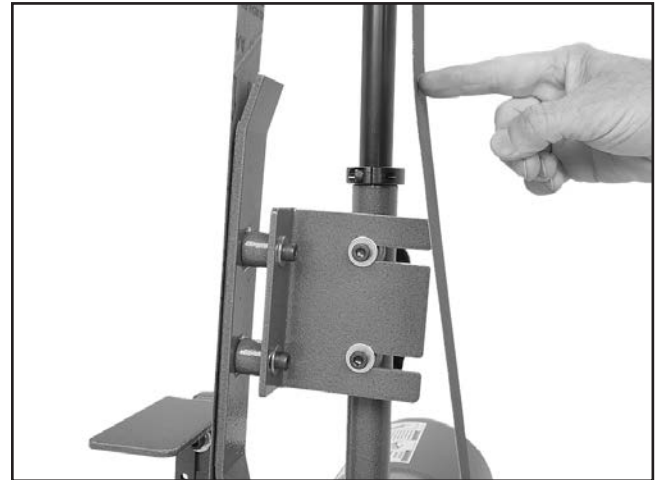

Figure 19. Checking the sanding belt tension.

The sanding belt is adjusted by raising or lowering the sanding arm assembly.

Tools Needed	Qty
Hex Wrench 3/16"	1

To correctly tension the sanding belt:

1. DISCONNECT MACHINE FROM POWER!
2. Make sure the sanding belt is correctly installed and centered on the idler and drive wheels.

!WARNING

If the sanding belt comes loose from the machine during operation, it could cause serious personal injury from entanglement or abrasion. **ALWAYS** make sure the sanding belt is properly installed, tensioned, and tracked before connecting the machine to power.



3. Hold onto the sanding arm assembly to keep it from moving, then loosen the threaded knobs and the lock collar cap screw shown in **Figure 20**.

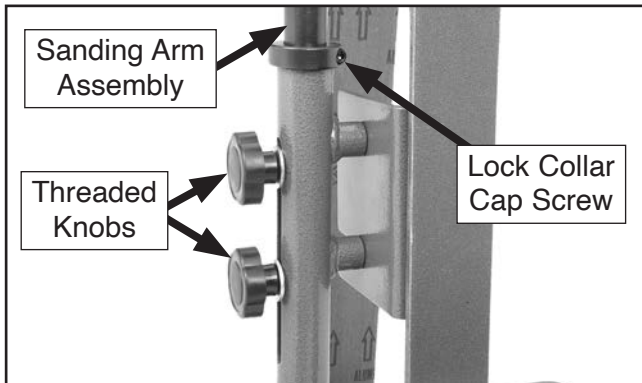

Figure 20. Sanding belt tension controls.

4. Adjust the height of the sanding arm assembly so there is the correct amount of tension on the sanding belt, then re-tighten the threaded knobs to hold the assembly in place.
5. Adjust the lock collar so that it is firmly seated on the pivot arm top, then re-tighten its cap screw.

Note: *The lock collar ensures the stability and position of the sanding arm beyond the holding power of the threaded knobs.*

6. Re-check the sanding belt tension. If necessary, repeat this procedure until the correct belt tension is achieved.

Adjusting Sanding Belt Tracking

To ensure a safe operation, the sanding belt must stay centered on the idler and drive wheels while the machine is **ON**. This is a trial-and-error process that requires some patience.

To adjust the sanding belt tracking:

1. DISCONNECT MACHINE FROM POWER!
2. Make sure the sanding belt is correctly installed and tensioned.

3. Rotate the drive wheel several times by hand and watch the sanding belt as it tracks on the idler and drive wheels.

- If sanding belt is centered on the idler and drive wheels, and does not move to one side or the other after several rotations, no further adjustments are necessary.
- If sanding belt moves to one side or the other while rotating, continue with this procedure.

4. Make a small adjustment to the tracking adjustment knob, then rotate the drive wheel several times while observing the sanding belt (see **Figure 21**).

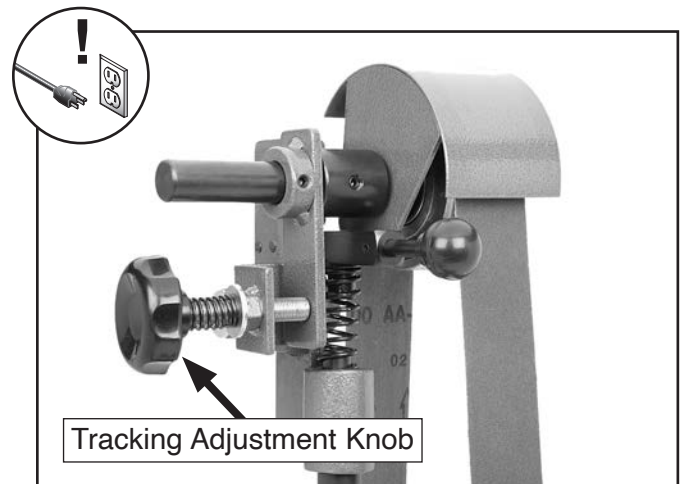

Figure 21. Location of tracking adjustment knob.

- If the sanding belt moves to the right, rotate the adjustment knob clockwise.
- If the sanding belt moves to the left, rotate the adjustment knob counterclockwise.

5. Repeat **Step 4** until the sanding belt stays centered on the idler and drive wheels after several rotations.
6. To verify the sanding belt tracking, turn the machine **ON** and watch the belt tracking.

- If the belt does not wander, then it is tracked correctly.
- If the belt does wander, very slowly adjust the tracking adjustment knob until the belt stays centered on the wheels.



Belt Sanding

The sanding belt is used to sand wood or metal. We recommend using aluminum oxide sanding belts for wood and silicon carbide for metal. Refer to **Accessories** on **Page 26** for options from Grizzly.

Always be sure the sanding belt is properly installed, tensioned, and tracked before connecting the machine to power (refer to the **Sanding Belt** subsection on **Page 20** for detailed instructions).

Always adjust the tool rest so that it is no more than $\frac{1}{16}$ " away from the belt. This helps to ensure that the workpiece does not get trapped between the rest and the belt.

Make sure the platen is centered on the sanding belt. This graphite-faced platen provides an excellent surface for angular sanding or polishing.

Figure 22 shows a typical wood sanding operation with the tool rest perpendicular to the belt surface.

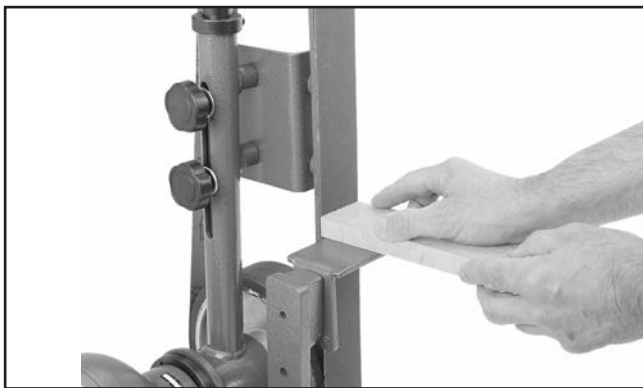

Figure 22. Typical wood sanding operation.

The sanding belt is also used for knife grinding and sharpening. **Figure 23** depicts a typical knife edge grinding operation. Generally, this is done with the tool rest removed.

Note: *There are many different techniques for using the sanding belt to grind and sharpen knives. Whichever one you use, make sure that you hold the knife firmly and ease it into the belt without excessive pressure to ensure a safe operation.*



Figure 23. Typical knife grinding operation.

The belt is also used for contour sanding. When doing this type of operation, it is best to remove the platen and the tool rest so the belt can flex to better conform to the shape of the workpiece (see **Figure 24**).

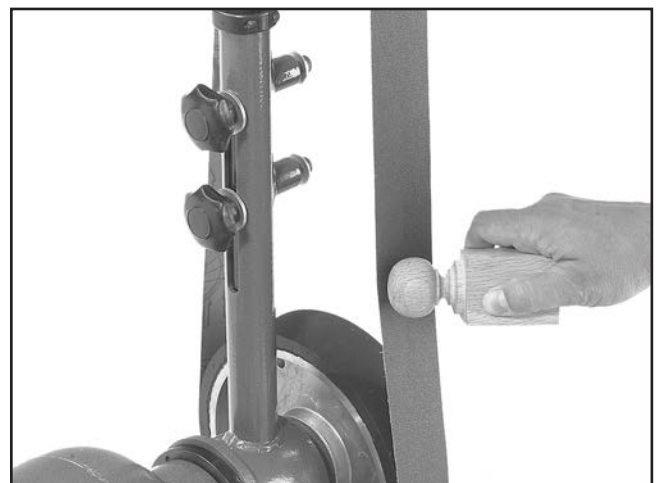

Figure 24. An example of contour sanding.



The sanding arm assembly tilts to a horizontal position, as shown in **Figure 25**. This arrangement is more convenient for certain types of sanding or grinding operations.

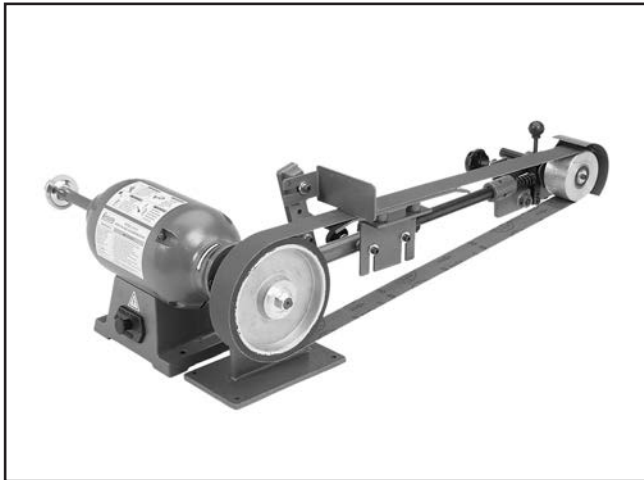

Figure 25. Sanding arm assembly in the horizontal position.

To position the sanding arm assembly horizontally:

1. DISCONNECT MACHINE FROM POWER!
2. While holding the arm assembly, loosen the two set screws in the round housing of the pivot arm.
3. Pivot the assembly to the desired angle, then re-tighten the pivot arm set screws to secure it in place.
4. Adjust the tool rest in the position that is correct for your operation.

Note: *If you will be using the contour of the drive wheel for sanding or grinding, remove the tool rest assembly so that it will not interfere with the operation. Otherwise, you will need to mount it differently so that it will not interfere with the sanding belt.*

5. Check and adjust, if necessary, the sanding belt tracking (refer to **Adjusting Sanding Belt Tracking** on **Page 21** for detailed instructions).

Installing Optional 10" Drive Wheel

The right-hand arbor can accommodate the optional Model G9242 10" drive wheel using the included 72" sanding belt.

Tools Needed	Qty
Hex Wrench $\frac{3}{16}$ "	1
Rubber Dead Blow Hammer	1
Adjustable Wrench	1

Installing 10" Drive Wheel

1. DISCONNECT MACHINE FROM POWER!
2. Pull down on quick-release lever (see **Figure 18**, on **Page 20**), and remove the sanding belt.
3. Remove the arbor hex nut, outer flange, and the included 8" drive wheel (see **Figure 26**).

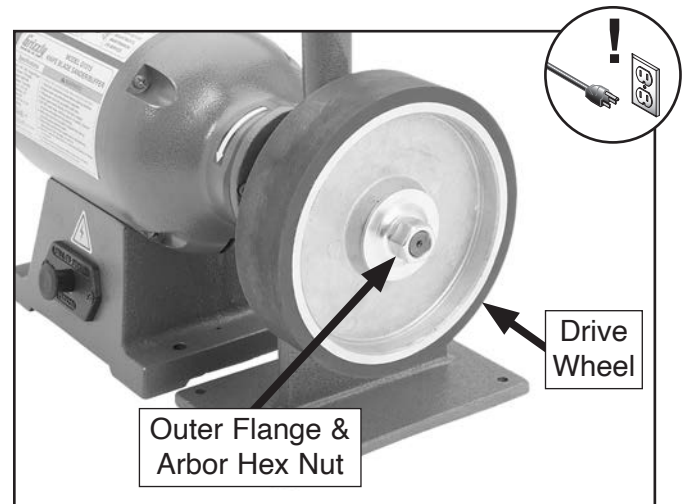

Figure 26. Location of outer flange and arbor hex nut.

4. Slide optional Model G9242 10" drive wheel onto right-hand arbor with outer flange, then secure it in place with the arbor hex nut.



- Loosen the threaded knobs and lock collar shown in **Figure 27** and lower sanding arm assembly.

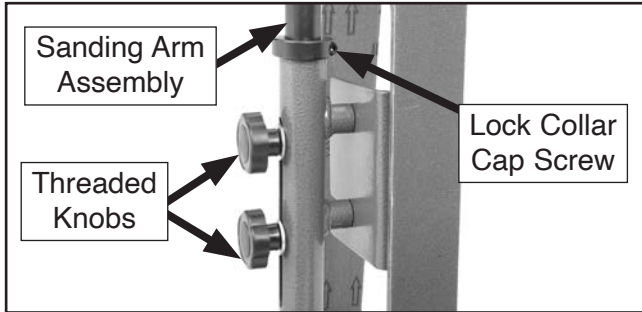

Figure 27. Sanding belt tension controls.

- With the direction arrows printed on the inside front of the belt facing down, wrap the belt around idler and drive wheels so that it is centered on both, as shown in **Figure 28**.

Note: To prevent the belt seam from catching on the workpiece, install the belt so that the direction arrows printed on the inside face of the belt follow the belt rotation, as shown in **Figure 28**.

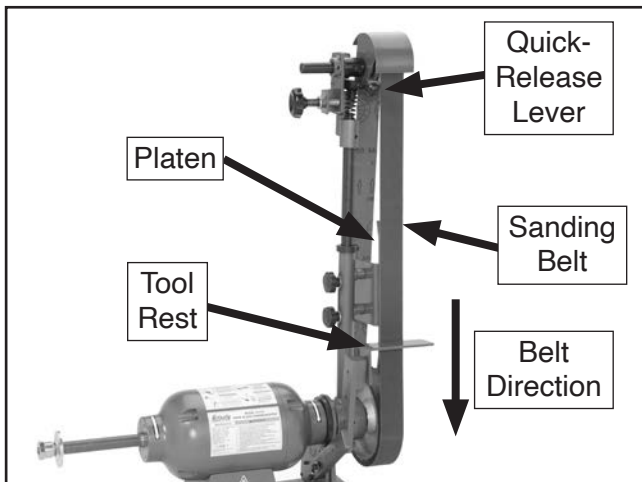

Figure 28. Sanding belt installed.

- Adjust the height of the sanding arm assembly so there is the correct amount of tension on the sanding belt (approximately $\frac{1}{2}$ " deflection), then install the threaded knobs into the upper and middle holes on the sanding arm assembly.

- Adjust the lock collar so that it is firmly seated on the pivot arm top, then re-tighten its cap screw.

Note: The lock collar ensures the stability and position of the sanding arm beyond the holding power of the threaded knobs.

- Re-check the sanding belt tension. If necessary, repeat this procedure until the correct belt tension is achieved.
- Adjust the platen (see **Figure 28**) so that it is centered behind the belt.
- If needed for your operation, adjust the tool rest position (see **Figure 28**) as required. Make sure that it is no more than $\frac{1}{16}$ " away from the sanding belt to prevent the workpiece being trapped between the tool rest and belt.
- Follow **Adjusting Sanding Belt Tracking** on **Page 21**.

Re-Installing 8" Drive Wheel

- Follow **Steps 1–6** from **Installing Optional 10" Drive Wheel** in a similar manner.
- Adjust the height of the sanding arm assembly so there is approximately $\frac{1}{2}$ " deflection on the sanding belt, then install the threaded knobs into the lower and middle holes on the sanding arm assembly.
- Follow **Steps 8–12** from **Installing Optional 10" Drive Wheel** in a similar manner.



Auxiliary Attachments

The auxiliary arbor accepts buffing, polishing, or sanding attachments with a $\frac{5}{8}$ " bore and up to a 10" diameter. Refer to **Accessories** on **Page 26** for options from Grizzly.

When mounting buffing wheels, sandwich them between the auxiliary flanges before sliding them onto the left side arbor, as shown in **Figure 29**, then install the $\frac{5}{8}$ " left-hand thread auxiliary arbor nut to secure it in place.

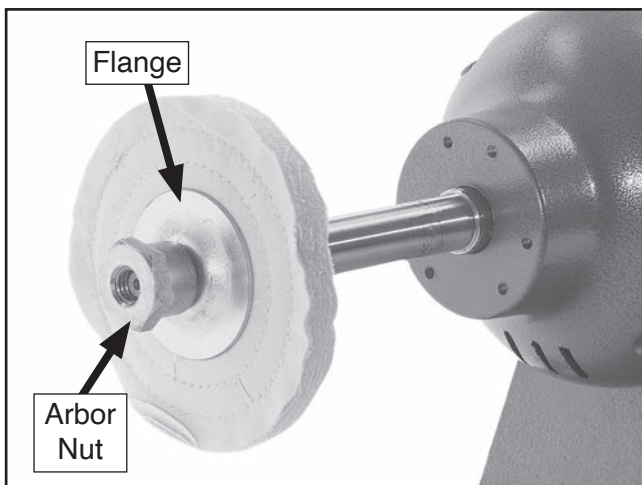

Figure 29. Buffing wheel installed.

Note: The installation of attachments other than buffing wheels do not require the flanges.

Make sure that you ease the workpiece into the attachment on the bottom front contour, as illustrated in **Figure 30**.

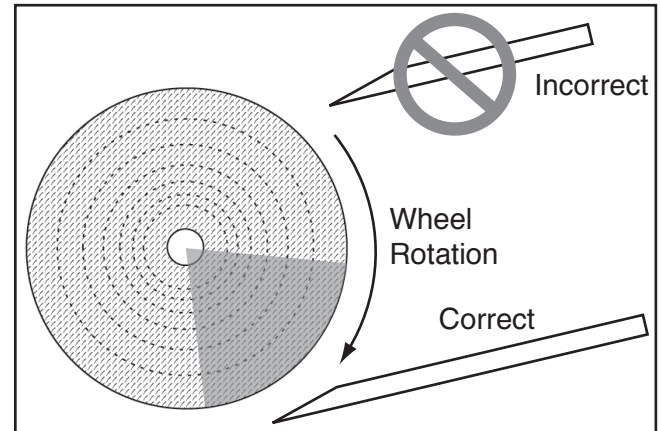

Figure 30. Using the bottom front contour of the attachment.



SECTION 5: ACCESSORIES

!WARNING

Installing unapproved accessories may cause machine to malfunction, resulting in serious personal injury or machine damage. To reduce this risk, only install accessories recommended for this machine by Grizzly.

NOTICE

Refer to our website or latest catalog for additional recommended accessories.

Sanding Belts for the Model G1015, 2" x 72"

D1221—Aluminum Oxide, 60 Grit
D1223—Aluminum Oxide, 100 Grit
D1225—Aluminum Oxide, 150 Grit
D1227—Aluminum Oxide, 220 Grit
D1278—Silicon Carbide, 80 Grit
D1281—Silicon Carbide, 150 Grit
G4874—Silicon Carbide, 240 Grit
G4875—Silicon Carbide, 320 Grit
G4876—Silicon Carbide, 6000 Grit

Loose Muslin Buffing Wheels

Soft feathered edge muslin is concentrically stitched near the center, leaving the outer edge to provide a fine polishing surface. Perfect for stainless steel, chrome, gold, or silver.

D3187—4"D x 40 Ply x $\frac{5}{8}$ " Bore
D3188—5"D x 40 Ply x $\frac{5}{8}$ " Bore
D3189—6"D x 40 Ply x $\frac{5}{8}$ " Bore
D3190—8"D x 40 Ply x $\frac{5}{8}$ " Bore



Figure 31. Muslin buffing wheel.

Spiral Sewn Buffing Wheels

Each layer is 100% unbleached cotton sheeting, spiral sewn approximately $\frac{1}{8}$ " apart. For final finishing on brass, stainless steel, aluminum, bronze, and cast iron. Available in plies of 30, 40, and 60 from 3" to 8" diameters.

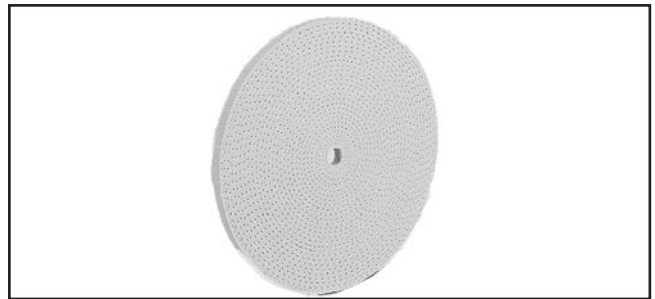

Figure 32. Spiral sewn buffing wheel.

High-End Buffing Compounds, Pastes, & Polishes

In our search for the best buffing and polishing compounds money can buy, we came across the German company **Menzerna** that makes compounds for virtually all buffing and polishing needs.

Airway-Hard Buffing Wheels

These buffs are 100% cotton that's been treated to stiffen the material. Pleats help hold compound. Perfect for removing light scratches in a variety of metals.

D3193—6"D x $\frac{5}{8}$ " Bore
D2517—8"D x $\frac{5}{8}$ " Bore

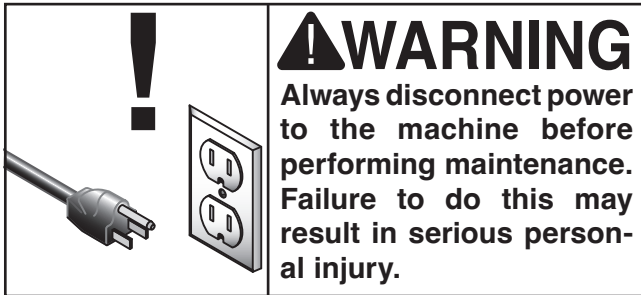

Figure 33. Airway-Hard buffing wheel.

order online at www.grizzly.com or call 1-800-523-4777



SECTION 6: MAINTENANCE



Schedule

For optimum performance from this machine, this maintenance schedule must be strictly followed.

Ongoing

To minimize your risk of injury and maintain proper machine operation, shut down the machine immediately if you ever observe any of the items below, and fix the problem before continuing operations:

- Loose mounting bolts.
- Damaged or worn sanding belt.
- Worn or damaged wires.
- Any other unsafe condition.

Monthly Check

- Lubricate pivot arm bushing.

Cleaning

Cleaning the Model G1015 is relatively easy. Vacuum excess chips, sawdust, and debris, then wipe off the remaining dust and grime with a dry cloth. If any resin has built up, use a resin dissolving cleaner to remove it. Treat all unpainted cast iron and steel with a non-staining lubricant after cleaning.

Lubrication

The bearings for the Model G1015 were lubricated and sealed at the factory. Merely leave them alone unless they need replacement.

To lubricate the pivot arm bushing, remove the sanding arm assembly and pivot arm, then apply a light coat of multi-purpose grease to the outer surface of the bushing (see **Figure 34**).

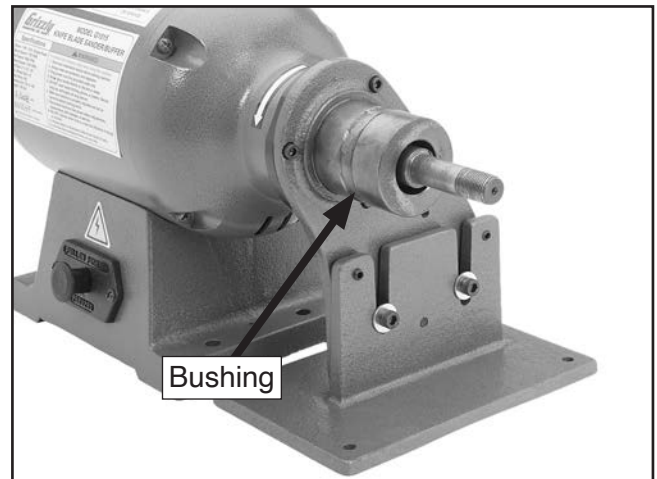

Figure 34. Pivot arm bushing.



SECTION 7: SERVICE

Review the troubleshooting procedures in this section if a problem develops with your machine. If you need replacement parts or additional help with a procedure, call our Technical Support. **Note:** *Please gather the serial number and manufacture date of your machine before calling.*

Troubleshooting

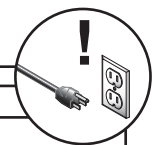

Symptom	Possible Cause	Possible Solution
Machine does not start or a breaker trips.	<ol style="list-style-type: none"> 1. Power supply switched OFF or at fault. 2. Plug/receptacle at fault/wired wrong. 3. Start capacitor at fault. 4. Wall circuit breaker tripped. 5. Wiring open/has high resistance. 6. Motor ON/OFF button at fault. 7. Centrifugal switch at fault. 8. Motor at fault. 	<ol style="list-style-type: none"> 1. Ensure power supply is on/has correct voltage. 2. Test for good contacts; correct the wiring. 3. Test/replace if faulty. 4. Ensure circuit size is correct/replace weak breaker. 5. Check/fix broken, disconnected, or corroded wires. 6. Replace button. 7. Inspect/replace. 8. Test/repair/replace.
Machine stalls or is underpowered.	<ol style="list-style-type: none"> 1. Too much load applied with workpiece. 2. Motor wired incorrectly. 3. Plug/receptacle at fault. 4. Motor bearings at fault. 5. Machine undersized for task. 6. Machine undersized for task. 7. Centrifugal switch at fault. 8. Motor at fault. 	<ol style="list-style-type: none"> 1. Ease workpiece into sanding belt/attachment with light pressure. 2. Wire motor correctly (Page 30). 3. Test for good contacts/correct wiring. 4. Test/repair/replace. 5. Use new grinding/buffing wheel; reduce feed rate. 6. Clean/replace sandpaper; reduce feed rate/sanding depth. 7. Inspect/replace. 8. Test/repair/replace.
Machine has vibration or noisy operation.	<ol style="list-style-type: none"> 1. Motor or component loose. 2. Idler/drive wheel loose. 3. Incorrectly mounted to workbench. 4. Motor bearings at fault. 5. Motor shaft bent. 	<ol style="list-style-type: none"> 1. Inspect/replace damaged bolts/nuts, and re-tighten with thread locking fluid. 2. Realign/replace shaft, wheel, set screw, and key. 3. Re-tighten mounting hardware; use shims. 4. Test by rotating shaft; rotational grinding/loose shaft requires bearing replacement. 5. Test with dial indicator and replace motor.
Sanding belt runs off wheels.	<ol style="list-style-type: none"> 1. Belt tracking not correct. 2. Belt not correctly tensioned. 3. Belt is damaged. 	<ol style="list-style-type: none"> 1. Adjust belt tracking (Page 21). 2. Correctly adjust the belt tension (Page 20). 3. Replace belt.
Sanding belt breaking or tearing.	<ol style="list-style-type: none"> 1. Belt tension too tight. 2. Belt rotation incorrect. 3. Poor quality/incorrect type belt. 	<ol style="list-style-type: none"> 1. Correctly adjust the belt tension (Page 20). 2. Make sure belt is installed with direction arrows following rotation direction (Page 20). 3. Replace belt with belt of correct type for operation.
Sanding belt makes grinding noise during operation.	<ol style="list-style-type: none"> 1. Belt rubbing against wheel housing. 2. Tool rest rubbing against belt. 3. Graphite coating on platen worn out. 4. Idler wheel bearing worn out. 	<ol style="list-style-type: none"> 1. Adjust upper wheel guard; correctly adjust belt tracking (Page 21). 2. Adjust tool rest away from belt no more than 1/8". 3. Replace platen. 4. Replace bearing and idler wheel.
Pivot arm hard to move.	<ol style="list-style-type: none"> 1. Pivot arm set screws tight. 2. Pivot arm bushing not lubricated. 	<ol style="list-style-type: none"> 1. Loosen pivot arm set screws before rotating the arm (Page 23). 2. Lubricate the bushing arm bushing (Page 27).



SECTION 8: WIRING

These pages are current at the time of printing. However, in the spirit of improvement, we may make changes to the electrical systems of future machines. Compare the manufacture date of your machine to the one stated in this manual, and study this section carefully.

If there are differences between your machine and what is shown in this section, call Technical Support at (570) 546-9663 for assistance BEFORE making any changes to the wiring on your machine. An updated wiring diagram may be available. **Note:** *Please gather the serial number and manufacture date of your machine before calling. This information can be found on the main machine label.*

WARNING

Wiring Safety Instructions

SHOCK HAZARD. Working on wiring that is connected to a power source is extremely dangerous. Touching electrified parts will result in personal injury including but not limited to severe burns, electrocution, or death. Disconnect the power from the machine before servicing electrical components!

MODIFICATIONS. Modifying the wiring beyond what is shown in the diagram may lead to unpredictable results, including serious injury or fire. This includes the installation of unapproved after-market parts.

WIRE CONNECTIONS. All connections must be tight to prevent wires from loosening during machine operation. Double-check all wires disconnected or connected during any wiring task to ensure tight connections.

CIRCUIT REQUIREMENTS. You MUST follow the requirements at the beginning of this manual when connecting your machine to a power source.

WIRE/COMPONENT DAMAGE. Damaged wires or components increase the risk of serious personal injury, fire, or machine damage. If you notice that any wires or components are damaged while performing a wiring task, replace those wires or components.

MOTOR WIRING. The motor wiring shown in these diagrams is current at the time of printing but may not match your machine. If you find this to be the case, use the wiring diagram inside the motor junction box.















CAPACITORS/INVERTERS. Some capacitors and power inverters store an electrical charge for up to 10 minutes after being disconnected from the power source. To reduce the risk of being shocked, wait at least this long before working on capacitors.

EXPERIENCING DIFFICULTIES. If you are experiencing difficulties understanding the information included in this section, contact our Technical Support at (570) 546-9663.

NOTICE

The photos and diagrams included in this section are best viewed in color. You can view these pages in color at www.grizzly.com.

COLOR KEY

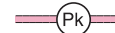
BLACK 	BLUE 	YELLOW 	LIGHT BLUE 
WHITE 	BROWN 	YELLOW GREEN 	BLUE WHITE 
GREEN 	GRAY 	PURPLE 	TURQUOISE 
RED 	ORANGE 	PINK 	



Wiring Diagram

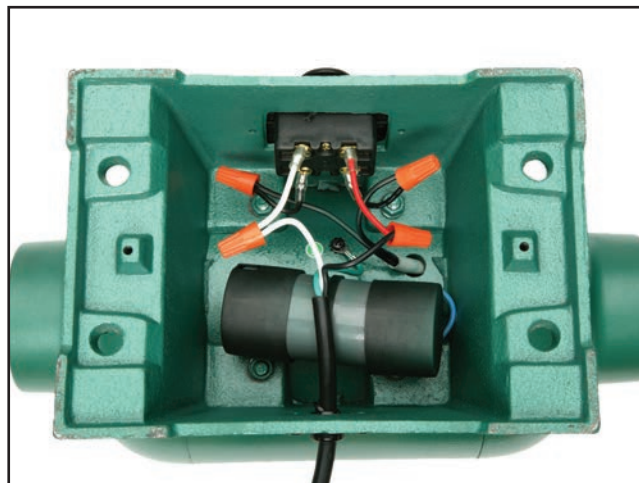
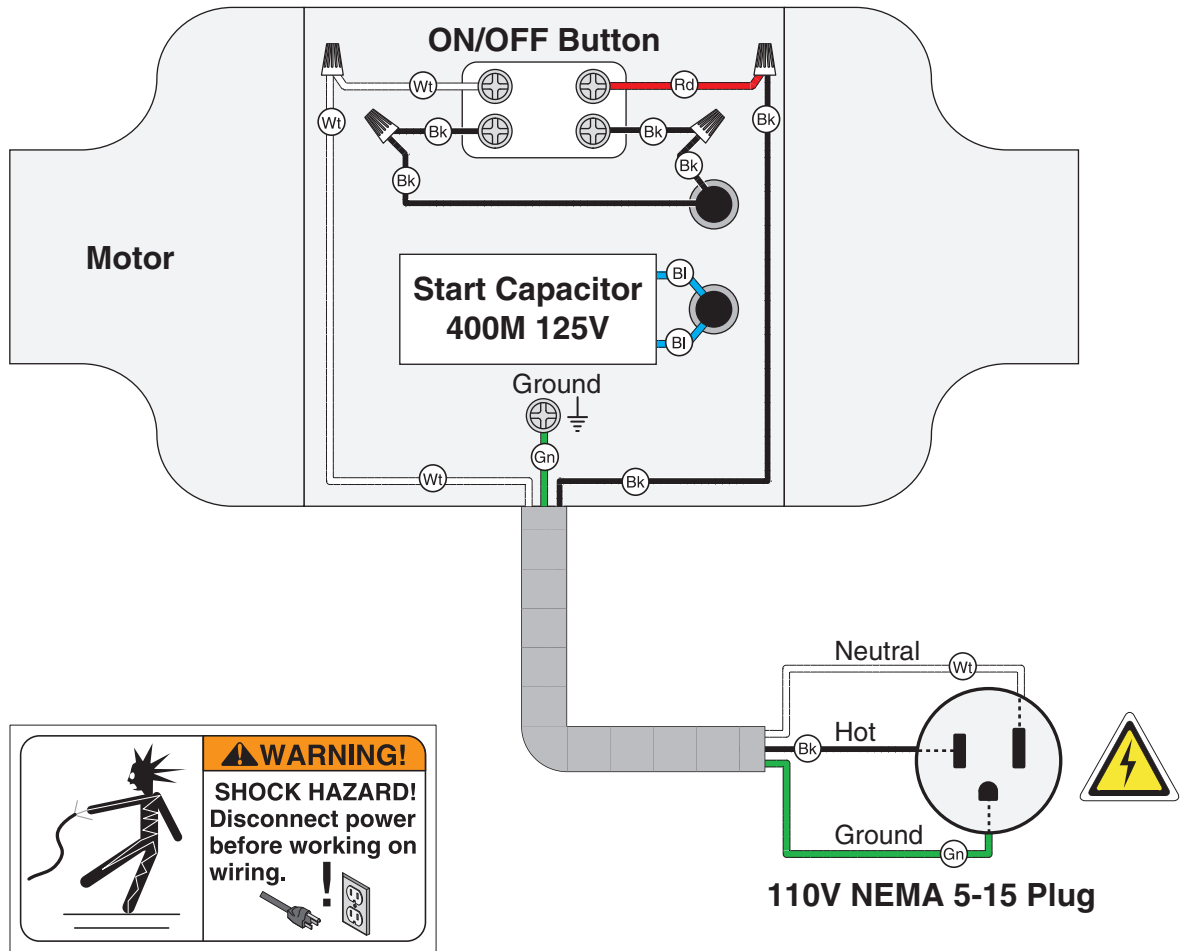

Figure 35. Electrical wiring.



SECTION 9: PARTS

We do our best to stock replacement parts when possible, but we cannot guarantee that all parts shown are available for purchase. Call (800) 523-4777 or visit www.grizzly.com/parts to check for availability.

Main

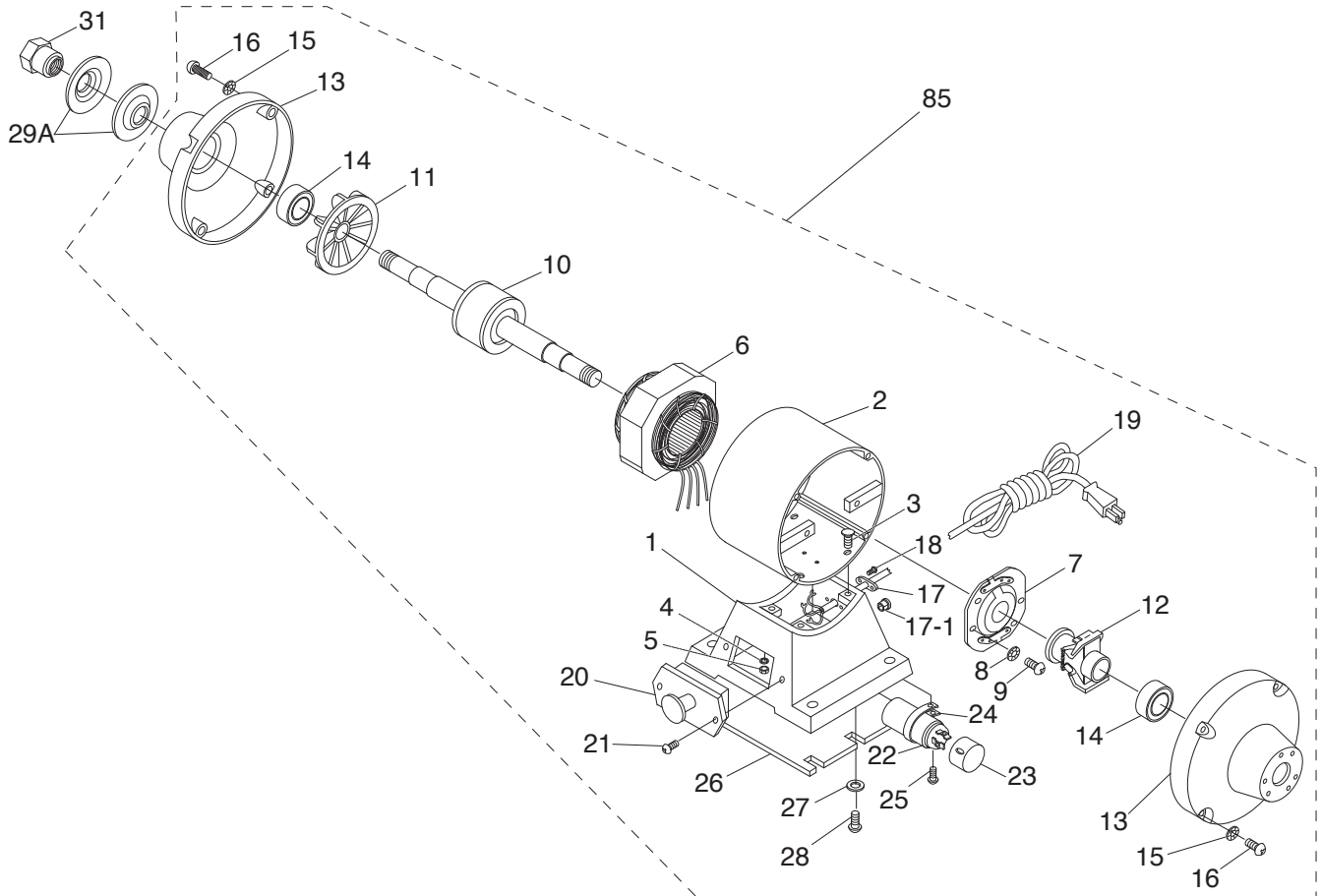

REF	PART #	DESCRIPTION
1	P1015001	BASE
2	P1015002	MOTOR CASE
3	P1015003	PHLP HD SCR 5/16-18 X 1-1/4
4	P1015004	LOCK WASHER 5/16
5	P1015005	HEX NUT 5/16-18
6	P1015006	STATOR WINDING
7	P1015007	CONTACT PLT, LG, INT PT
8	P1015008	LOCK WASHER 3/16
9	P1015009	PHLP HD SCR 10-24 X 1/2
10	P1015010	ROTOR/SHAFT
11	P1015011	FAN
12	P1015012	CENTRIFUGAL SWITCH
13	P1015013	END BELL
14	P1015014	BALL BEARING 6206ZZ
15	P1015015	LOCK WASHER 1/4
16	P1015016	PHLP HD SCR 1/4-20 X 5/8

REF	PART #	DESCRIPTION
17	P1015017	CORD CLAMP
17-1	P1015017-1	STRAIN RELIEF
18	P1015018	PHLP HD SCR 10-24 X 1-1/4
19	P1015019	POWER CORD 16GA/3W 73"L
20	P1015020	ON/OFF BUTTON
21	P1015021	PHLP HD SCR 10-24 X 1/2
22	P1015022	S CAPACITOR 400M 125V 1-3/4 X 3-3/8
23	P1015023	CAPACITOR COVER
24	P1015024	CAPACITOR CLAMP
25	P1015025	PHLP HD SCR 10-24 X 3/8
26	P1015026	COVER PLATE
27	P1015027	FLAT WASHER 1/4
28	P1015028	PHLP HD SCR 10-24 X 3/8
29A	P1015029A	WHEEL FLANGE 64.7 X 19.2 X 2.8MM
31	P1015031	ARBOR NUT 5/8-18 LH
85	P1015085	COMPLETE MOTOR ASSEMBLY



Sanding Assembly Parts List

REF PART #	DESCRIPTION
29	P1015029 WHEEL FLANGE 73.2 X 16.1 X 2.8MM
30	P1015030 HEX NUT 3/4-16
32A	P1015032A PIVOT ARM MOUNTING BRACKET
33B	P1015033B PIVOT BRACKET W/BUSHING V3.12.95
33C	P1015033C PIVOT BRACKET W/O BUSHING V4.07.99
34	P1015034 CAP SCREW 5/16-18 X 1
35	P1015035 SET SCREW 5/16-18 X 1/2
36A	P1015036A PIVOT ARM
37	P1015037 SET SCREW 3/8-16 X 1/2
38A	P1015038A SHAFT 1"
39A	P1015039A KNOB 3/8-16
40A	P1015040A FLAT WASHER 3/8
41A	P1015041A COLLAR FOR 1" SHAFT
42A	P1015042A CAP SCREW 1/4-28 x 5/8
43	P1015043 COMPRESSION SPRING D22.3 X 87MM
44	P1015044 UPPER SHAFT BRACKET
45	P1015045 SET SCREW 5/16-18 X 1/4
46A	P1015046A TRACKING BRACKET
47	P1015047 CAP SCREW 1/4-20 X 1/2
48	P1015048 PIVOT BRACKET
49	P1015049 SHAFT
50	P1015050 TRACKING LEVER
51	P1015051 LOCK NUT 3/8-16
52A	P1015052A TRACKING KNOB 1/2-20
53A	P1015053A COMPRESSION SPRING D18 X 56MM
54	P1015054 FLAT WASHER 1/2
55A	P1015055A TENSION BAR 4-1/8"
56A	P1015056A TENSION KNOB SHAFT
57	P1015057 TENSION KNOB 3/8-16
58A	P1015058A ROLL PIN 5 X 20

REF PART #	DESCRIPTION
59	P1015059 CAP SCREW 5/16-18 X 3/4
60V2	P1015060V2 LOCK WASHER 1/4 V2.10.24
61V2	P1015061V2 BUTTON HD CAP SCR 1/4-20 X 1/2 V2.10.24
62A	P1015062A SPRING BUSHING
63	P1015063 CAP SCREW 1/4-20 X 1
64	P1015064 AXLE
65	P1015065 PIVOT BUSHING
66	P1015066 SET SCREW 1/4-20 X 3/8
67	P1015067 WHEEL GUARD
68	P1015068 SET SCREW 5/16-18 X 1/4
69	P1015069 BALL BEARING 6204ZZ
70	P1015070 FLAT WASHER 1/4
71	P1015071 CAP SCREW 1/4-20 X 1/2
72	P1015072 IDLER WHEEL
73	P1015073 DRIVE WHEEL 8"
74	P1015074 PLATEN BRACKET
75	P1015075 PLATEN
75A	P1015075A GRAPHITE PAD 2"W X 9"L
76	P1015076 CAP SCREW 5/16-18 X 3/4
77	P1015077 ROLL PIN 1/8 X 1
78	P1015078 TOOL REST SUPPORT LEFT
79	P1015079 TOOL REST SUPPORT RIGHT
80	P1015080 CAP SCREW 5/16-18 X 1
81	P1015081 FLAT WASHER 5/16
82	P1015082 CAP SCREW 5/16-18 X 3/4
83	P1015083 TOOL REST
84	P1015084 SANDING BELT 2" X 72" 100GR
86	P1015086 CAP SCREW 5/16-18 X 1-1/4
87	P1015087 CAP SCREW 1/4-20 X 1/2
88	P1015088 MOUNTING ADAPTOR



Labels & Cosmetics

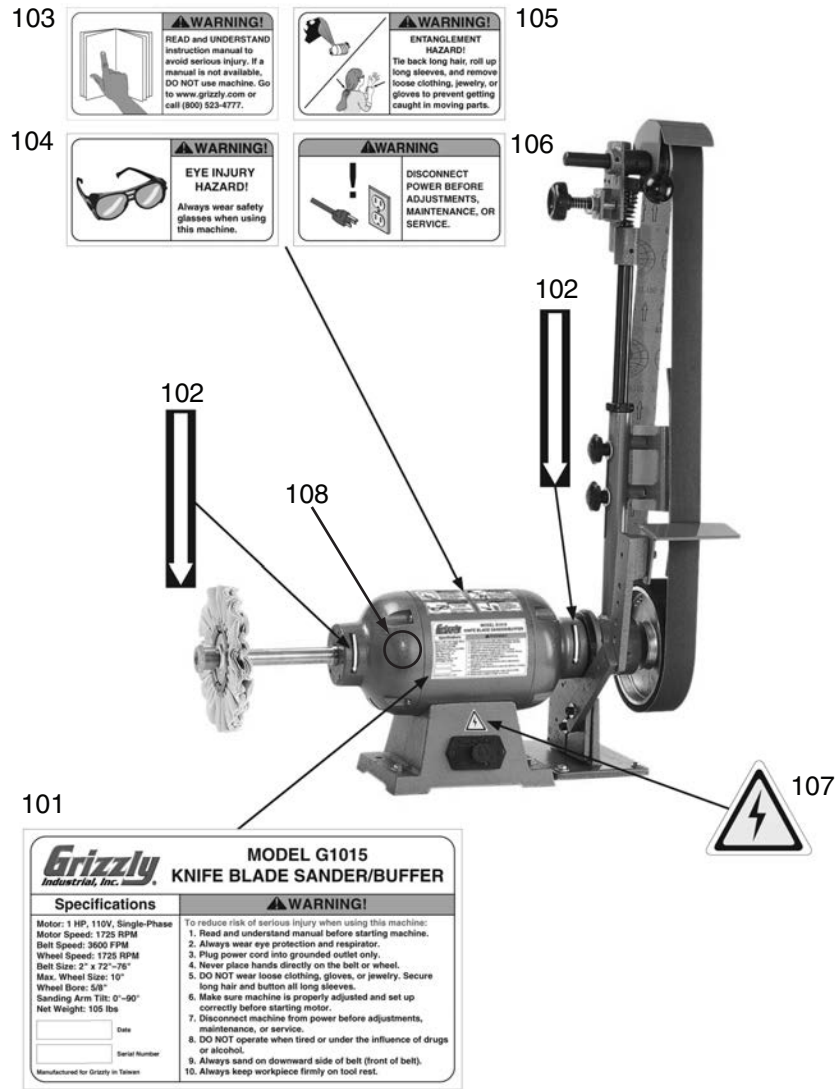

Grizzly Industrial, Inc. MODEL G1015 KNIFE BLADE SANDER/BUFFER

Specifications	WARNING!
Motor: 1 HP, 110V, Single-Phase Motor Speed: 1725 RPM Belt Speed: 3600 FPM Wheel Speed: 1725 RPM Belt Size: 2" x 72" -76" Max. Wheel Size: 10" Wheel Bore: 5/8" Sanding Arm Tilt: 0°-90° Net Weight: 105 lbs	To reduce risk of serious injury when using this machine: 1. Read and understand manual before starting machine. 2. Always wear eye protection and respirator. 3. Plug power cord into grounded outlet only. 4. Never place hands directly on the belt or wheel. 5. DO NOT wear loose clothing, gloves, or jewelry. Secure long hair and button all long sleeves. 6. Make sure machine is properly adjusted and set up correctly before starting motor. 7. Disconnect machine from power before adjustments, maintenance, or service. 8. DO NOT operate when tired or under the influence of drugs or alcohol. 9. Always sand on downward side of belt (front of belt). 10. Always keep workpiece firmly on tool rest.
Date: _____	
Serial Number: _____	
Manufactured for Grizzly in Taiwan	

REF	PART #	DESCRIPTION
101	P1015101	MACHINE ID LABEL
102	P1015102	ROTATION DIRECTION LABEL
103	P1015103	READ MANUAL LABEL
104	P1015104	EYE INJURY HAZARD LABEL

REF	PART #	DESCRIPTION
105	P1015105	ENTANGLEMENT HAZARD LABEL
106	P1015106	DISCONNECT WARNING LABEL
107	P1015107	ELECTRICITY LABEL
108	P1015108	GRIZZLY GREEN TOUCH-UP PAINT

! WARNING

Safety labels help reduce the risk of serious injury caused by machine hazards. If any label comes off or becomes unreadable, the owner of this machine **MUST** replace it in the original location before resuming operations. For replacements, contact (800) 523-4777 or www.grizzly.com.

BUY PARTS ONLINE AT GRIZZLY.COM!
Scan QR code to visit our Parts Store.



WARRANTY & RETURNS

Grizzly Industrial, Inc. warrants every product it sells for a period of **1 year** to the original purchaser from the date of purchase. This warranty does not apply to defects due directly or indirectly to misuse, abuse, negligence, accidents, repairs or alterations or lack of maintenance. This is Grizzly's sole written warranty and any and all warranties that may be implied by law, including any merchantability or fitness, for any particular purpose, are hereby limited to the duration of this written warranty. We do not warrant or represent that the merchandise complies with the provisions of any law or acts unless the manufacturer so warrants. In no event shall Grizzly's liability under this warranty exceed the purchase price paid for the product and any legal actions brought against Grizzly shall be tried in the State of Washington, County of Whatcom.

We shall in no event be liable for death, injuries to persons or property or for incidental, contingent, special, or consequential damages arising from the use of our products.

The manufacturers reserve the right to change specifications at any time because they constantly strive to achieve better quality equipment. We make every effort to ensure that our products meet high quality and durability standards and we hope you never need to use this warranty.

In the event you need to use this warranty, contact us by mail or phone and give us all the details. We will then issue you a "Return Number," which must be clearly posted on the outside as well as the inside of the carton. We will not accept any item back without this number. Proof of purchase must accompany the merchandise.

Please feel free to write or call us if you have any questions about the machine or the manual.

Thank you again for your business and continued support. We hope to serve you again soon.

For further information about the warranty, visit <https://www.grizzly.com/forms/warranty> or scan the QR code below to be automatically directed to our warranty page.



grizzly.com[®]
TOOL WEBSITE

Buy Direct and Save with Grizzly[®] – Trusted, Proven and a Great Value!
~Since 1983~

*Visit Our Website Today For
Current Specials!*

**ORDER
24 HOURS A DAY!
1-800-523-4777**

