

# READ THIS FIRST



Model G0604ZX

**\*\*\*IMPORTANT UPDATE\*\*\***

For Machines Mfd. Since 04/15  
and Manual Insert Printed 09/07

For questions or help with this product contact Tech Support at (570) 546-9663 or [techsupport@grizzly.com](mailto:techsupport@grizzly.com)

The following changes were recently made to this machine since the manual insert was printed:

- Changed spiral cutterhead and indexable inserts.

Aside from this information, all other content in the owner's manual applies and **MUST** be read and understood for your own safety. **IMPORTANT: Keep this update with the owner's manual for future reference.**

For questions or help, contact our Tech Support at (570) 546-9663 or [techsupport@grizzly.com](mailto:techsupport@grizzly.com).

## Revised Parts

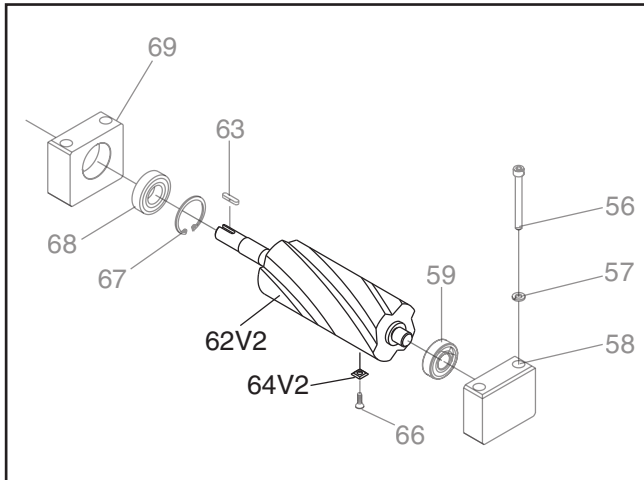

REF	PART #	DESCRIPTION
62V2	P0604ZX062V2	SPIRAL CUTTERHEAD 6" V2.04.15
64V2	P0604ZX064V2	CARBIDE INSERT 14 X 14 X 2MM V2.04.15

COPYRIGHT © SEPTEMBER, 2015 BY GRIZZLY INDUSTRIAL, INC.  
**WARNING: NO PORTION OF THIS MANUAL MAY BE REPRODUCED IN ANY SHAPE  
OR FORM WITHOUT THE WRITTEN APPROVAL OF GRIZZLY INDUSTRIAL, INC.**  
#JH17636 PRINTED IN CHINA

# READ THIS FIRST



## Model G0604X/ZX

### \*\*\*IMPORTANT UPDATE\*\*\*

For Machines Mfg. Since August, 2012  
and Owner's Manual Printed June, 2006

The following changes were recently made to these machines since the owner's manual was printed:

- Now CSA certified to meet CSA 22.2 #71.2-08 and UL 987-7th standards.
- Changed the motor nominal voltage specifications from 110V/220V to 120V/240V.

This document provides relevant updates to portions of the owner's manual that no longer apply and additional information required by CSA—aside from this information, all other content in the owner's manual applies and **MUST** be read and understood for your own safety. **IMPORTANT: Keep this update with the owner's manual for future reference.**

For questions or help, contact our Tech Support at (570) 546-9663 or [techsupport@grizzly.com](mailto:techsupport@grizzly.com).

## Changed Specifications

### Electrical

Power Requirement.....	120V/240V, Single-Phase, 60 Hz
Prewired Voltage.....	120V
Switch Voltage.....	120V/240V

### Motor

Voltage .....	120V/240V
---------------	-----------

### Operation Info

Cutterhead Speed .....	4800 RPM
------------------------	----------



COPYRIGHT © JULY, 2012 BY GRIZZLY INDUSTRIAL, INC.  
**WARNING: NO PORTION OF THIS MANUAL MAY BE REPRODUCED IN ANY SHAPE  
OR FORM WITHOUT THE WRITTEN APPROVAL OF GRIZZLY INDUSTRIAL, INC.**  
#BL15172 PRINTED IN CHINA

## New/Revised G0604X Parts

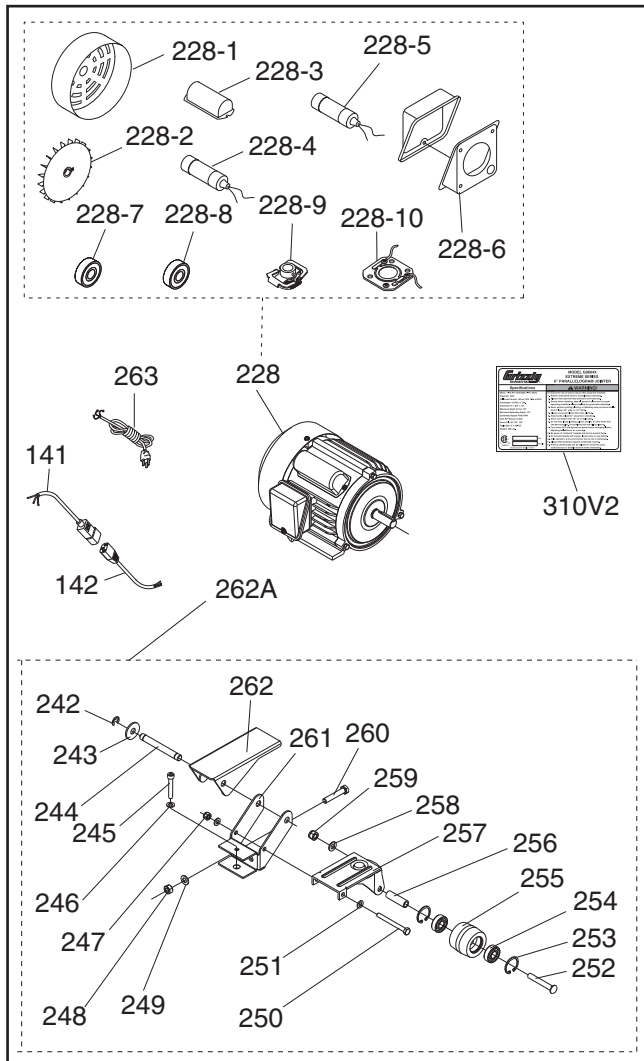

## New/Revised G0604ZX Parts

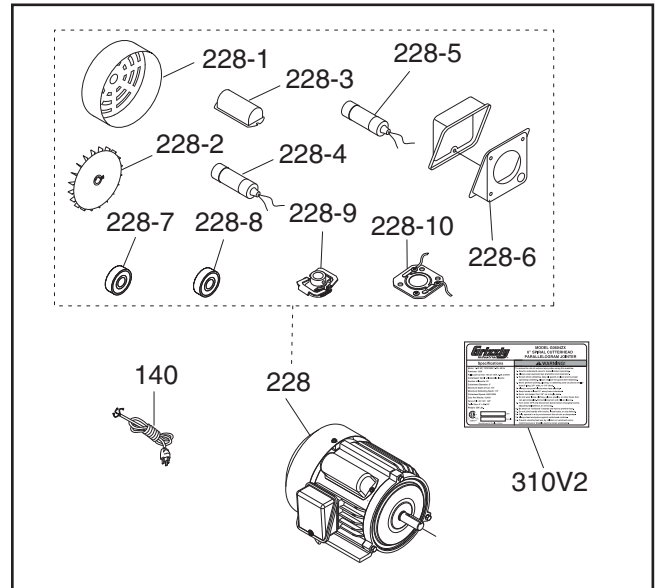

REF	PART #	DESCRIPTION
140	P0604ZX140	POWER CORD 14G 3W 72" 5-15P
228	P0604X228	MOTOR 1.5HP 120/240V 1-PH
228-1	P0604X228-1	FAN COVER
228-2	P0604X228-2	MOTOR FAN
228-3	P0604X228-3	CAPACITOR COVER
228-4	P0604X228-4	S CAPACITOR 300M 125V
228-5	P0604X228-5	R CAPACITOR 40M 250V
228-6	P0604X228-6	JUNCTION BOX
228-7	P6203ZZ	BALL BEARING 6203ZZ
228-8	P6202ZZ	BALL BEARING 6202ZZ
228-9	P0604X228-9	CENTRIFUGAL SWITCH 14MM 3450
228-10	P0604X228-10	CONTACT PLATE 14MM
310V2	P0604ZX310V2	MACHINE ID LABEL CSA V2.08.12

REF	PART #	DESCRIPTION
141	P0452075A-6	SWITCH CORD
142	P0452075A-7	MOTOR CORD
228	P0604X228	MOTOR 1.5HP 120/240V 1-PH
228-1	P0604X228-1	FAN COVER
228-2	P0604X228-2	MOTOR FAN
228-3	P0604X228-3	CAPACITOR COVER
228-4	P0604X228-4	S CAPACITOR 300M 125V
228-5	P0604X228-5	R CAPACITOR 40M 250V
228-6	P0604X228-6	JUNCTION BOX
228-7	P6203ZZ	BALL BEARING 6203ZZ
228-8	P6202ZZ	BALL BEARING 6202ZZ
228-9	P0604X228-9	CENTRIFUGAL SWITCH 14MM 3450
228-10	P0604X228-10	CONTACT PLATE 14MM
262A	P0656231	PEDAL ASSEMBLY
263	P0604ZX140	POWER CORD 14G 3W 72" 5-15P
310V2	P0604X310V2	MACHINE ID LABEL CSA V2.08.12



# SECTION 1: SAFETY

## For Your Own Safety, Read Instruction Manual Before Operating this Machine

The purpose of safety symbols is to attract your attention to possible hazardous conditions. This manual uses a series of symbols and signal words intended to convey the level of importance of the safety messages. The progression of symbols is described below. Remember that safety messages by themselves do not eliminate danger and are not a substitute for proper accident prevention measures. Always use common sense and good judgement.



Indicates an imminently hazardous situation which, if not avoided, **WILL** result in death or serious injury.



Indicates a potentially hazardous situation which, if not avoided, **COULD** result in death or serious injury.



Indicates a potentially hazardous situation which, if not avoided, **MAY** result in minor or moderate injury. It may also be used to alert against unsafe practices.

**NOTICE**

This symbol is used to alert the user to useful information about proper operation of the machine.

## Safety Instructions for Machinery



**OWNER'S MANUAL.** Read and understand this owner's manual **BEFORE** using machine.

**TRAINED OPERATORS ONLY.** Untrained operators have a higher risk of being hurt or killed. Only allow trained/supervised people to use this machine. When machine is not being used, disconnect power, remove switch keys, or lock-out machine to prevent unauthorized use—especially around children. Make workshop kid proof!

**DANGEROUS ENVIRONMENTS.** Do not use machinery in areas that are wet, cluttered, or have poor lighting. Operating machinery in these areas greatly increases the risk of accidents and injury.

**MENTAL ALERTNESS REQUIRED.** Full mental alertness is required for safe operation of machinery. Never operate under the influence of drugs or alcohol, when tired, or when distracted.

**ELECTRICAL EQUIPMENT INJURY RISKS.** You can be shocked, burned, or killed by touching live electrical components or improperly grounded machinery. To reduce this risk, only allow qualified service personnel to do electrical installation or repair work, and always disconnect power before accessing or exposing electrical equipment.

**DISCONNECT POWER FIRST.** Always disconnect machine from power supply **BEFORE** making adjustments, changing tooling, or servicing machine. This prevents an injury risk from unintended startup or contact with live electrical components.

**EYE PROTECTION.** Always wear ANSI-approved safety glasses or a face shield when operating or observing machinery to reduce the risk of eye injury or blindness from flying particles. Everyday eyeglasses are not approved safety glasses.



# WARNING

**WEARING PROPER APPAREL.** Do not wear clothing, apparel or jewelry that can become entangled in moving parts. Always tie back or cover long hair. Wear non-slip footwear to avoid accidental slips, which could cause loss of workpiece control.

**HAZARDOUS DUST.** Dust created while using machinery may cause cancer, birth defects, or long-term respiratory damage. Be aware of dust hazards associated with each workpiece material, and always wear a NIOSH-approved respirator to reduce your risk.

**HEARING PROTECTION.** Always wear hearing protection when operating or observing loud machinery. Extended exposure to this noise without hearing protection can cause permanent hearing loss.

**REMOVE ADJUSTING TOOLS.** Tools left on machinery can become dangerous projectiles upon startup. Never leave chuck keys, wrenches, or any other tools on machine. Always verify removal before starting!

**INTENDED USAGE.** Only use machine for its intended purpose and never make modifications not approved by Grizzly. Modifying machine or using it differently than intended may result in malfunction or mechanical failure that can lead to serious personal injury or death!

**AWKWARD POSITIONS.** Keep proper footing and balance at all times when operating machine. Do not overreach! Avoid awkward hand positions that make workpiece control difficult or increase the risk of accidental injury.

**CHILDREN & BYSTANDERS.** Keep children and bystanders at a safe distance from the work area. Stop using machine if they become a distraction.

**GUARDS & COVERS.** Guards and covers reduce accidental contact with moving parts or flying debris. Make sure they are properly installed, undamaged, and working correctly.

**FORCING MACHINERY.** Do not force machine. It will do the job safer and better at the rate for which it was designed.

**NEVER STAND ON MACHINE.** Serious injury may occur if machine is tipped or if the cutting tool is unintentionally contacted.

**STABLE MACHINE.** Unexpected movement during operation greatly increases risk of injury or loss of control. Before starting, verify machine is stable and mobile base (if used) is locked.

**USE RECOMMENDED ACCESSORIES.** Consult this owner's manual or the manufacturer for recommended accessories. Using improper accessories will increase the risk of serious injury.

**UNATTENDED OPERATION.** To reduce the risk of accidental injury, turn machine **OFF** and ensure all moving parts completely stop before walking away. Never leave machine running while unattended.

**MAINTAIN WITH CARE.** Follow all maintenance instructions and lubrication schedules to keep machine in good working condition. A machine that is improperly maintained could malfunction, leading to serious personal injury or death.

**CHECK DAMAGED PARTS.** Regularly inspect machine for any condition that may affect safe operation. Immediately repair or replace damaged or mis-adjusted parts before operating machine.

**MAINTAIN POWER CORDS.** When disconnecting cord-connected machines from power, grab and pull the plug—NOT the cord. Pulling the cord may damage the wires inside. Do not handle cord/plug with wet hands. Avoid cord damage by keeping it away from heated surfaces, high traffic areas, harsh chemicals, and wet/damp locations.

**EXPERIENCING DIFFICULTIES.** If at any time you experience difficulties performing the intended operation, stop using the machine! Contact our Technical Support at (570) 546-9663.



# Additional Safety for Jointers

## WARNING

**JOINTER INJURY RISKS.** Familiarize yourself with the main injury risks associated with jointers—always use common sense and good judgment to reduce your risk of injury. **Main injury risks from jointers:** amputation/lacerations from contact with the moving cutterhead, entanglement/crushing injuries from getting caught in moving parts, blindness or eye injury from flying wood chips, or impact injuries from workpiece kickback.

**KICKBACK.** Know how to reduce the risk of kickback and kickback-related injuries. “Kickback” occurs during the operation when the workpiece is ejected from the machine at a high rate of speed. Kickback is commonly caused by poor workpiece selection, unsafe feeding techniques, or improper machine setup/maintenance. Kickback injuries typically occur as follows: (1) operator/bystanders are struck by the workpiece, resulting in impact injuries (i.e., blindness, broken bones, bruises, death); (2) operator’s hands are pulled into blade, resulting in amputation or severe lacerations.

**GUARD REMOVAL.** Except when rabbeting, never remove guards during operation or while connected to power. Always replace guard after rabbeting. You could be seriously injured if you accidentally touch the spinning cutterhead or get entangled in moving parts. Before removing sawdust, turn jointer **OFF** and disconnect power before clearing. Immediately replace guards.

**DULL/DAMAGED KNIVES/INSERTS.** Only use sharp, undamaged knives/inserts. Dull, damaged or rusted knives/inserts increase risk of kickback.

**OUTFEED TABLE ALIGNMENT.** To reduce the risk of kickback and personal injuries, keep the outfeed table even with the knives/inserts at top dead center (the highest point during rotation). If the outfeed table is set too low, the workpiece may rock against the cutterhead. If the table is set too high, the workpiece may hit the outfeed table and get stuck over the cutterhead.

**INSPECTING STOCK.** To reduce the risk of kickback injuries or machine damage, thoroughly inspect and prepare the workpiece before cutting. Verify the workpiece is free of nails, staples, loose knots or other foreign material. Workpieces with minor warping should be surface planed first with the cupped side facing the infeed table.

**GRAIN DIRECTION.** Jointing against the grain or end grain increases the required cutting force, which could produce chatter or excessive chip out, and lead to kickback.

**CUTTING LIMITATIONS.** To reduce the risk of accidental cutterhead contact or kickback, never perform jointing, planing, or rabbeting cuts on pieces smaller than 8" long,  $\frac{3}{4}$ " wide, or  $\frac{1}{4}$ " thick.

**MAXIMUM CUTTING DEPTH.** To reduce the risk of kickback, never cut deeper than  $\frac{1}{8}$ " per pass.

**PUSH BLOCKS.** To reduce the risk of accidental cutterhead contact, always use push blocks when planing materials less than 3" high or wide. Never pass your hands directly over the cutterhead without a push block.

**WORKPIECE SUPPORT.** To reduce accidental cutterhead contact and kickback, support workpiece continuously during operation. Position and guide workpiece with fence; support long or wide stock with auxiliary stands.

**FEED WORKPIECE PROPERLY.** To reduce the risk of kickback, never start jointer with workpiece touching cutterhead. Allow cutterhead to reach full speed before feeding. Never back work toward the infeed table.

**SECURE KNIVES/INSERTS.** Loose knives or improperly set inserts can become dangerous projectiles or cause machine damage. Always verify knives/inserts are secure and properly adjusted before operation. Straight knives should never project more than  $\frac{1}{8}$ " (0.125") from cutterhead body.



# SECTION 2: POWER SUPPLY

## Availability

Before installing the machine, consider the availability and proximity of the required power supply circuit. If an existing circuit does not meet the requirements for this machine, a new circuit must be installed. To minimize the risk of electrocution, fire, or equipment damage, installation work and electrical wiring must be done by an electrician or qualified service personnel in accordance with all applicable codes and standards.

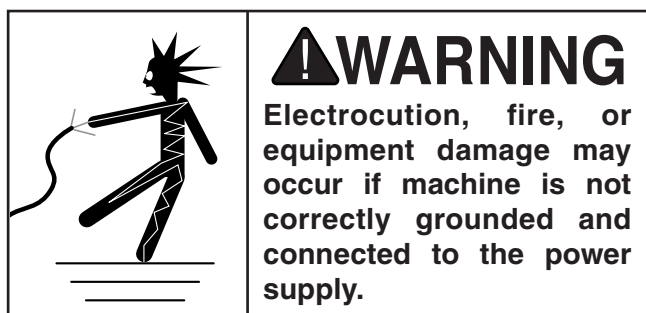

## Full-Load Current Rating

The full-load current rating is the amperage a machine draws at 100% of the rated output power. On machines with multiple motors, this is the amperage drawn by the largest motor or sum of all motors and electrical devices that might operate at one time during normal operations.

**Full-Load Current Rating at 120V ..... 15 Amps**

**Full-Load Current Rating at 240V .... 7.5 Amps**

The full-load current is not the maximum amount of amps that the machine will draw. If the machine is overloaded, it will draw additional amps beyond the full-load rating.

If the machine is overloaded for a sufficient length of time, damage, overheating, or fire may result—especially if connected to an undersized circuit. To reduce the risk of these hazards, avoid overloading the machine during operation and make sure it is connected to a power supply circuit that meets the requirements in the following section.

## Circuit Information

A power supply circuit includes all electrical equipment between the breaker box or fuse panel in the building and the machine. The power supply circuit used for this machine must be sized to safely handle the full-load current drawn from the machine for an extended period of time. (If this machine is connected to a circuit protected by fuses, use a time delay fuse marked D.)

**! CAUTION**  
For your own safety and protection of property, consult an electrician if you are unsure about wiring practices or electrical codes in your area.

*Note: The circuit requirements listed in this manual apply to a dedicated circuit—where only one machine will be running at a time. If this machine will be connected to a shared circuit where multiple machines will be running at the same time, consult a qualified electrician to ensure that the circuit is properly sized for safe operation.*

## Circuit Requirements for 120V

This machine is prewired to operate on a 120V power supply circuit that has a verified ground and meets the following requirements:

**Nominal Voltage ..... 120V**  
**Cycle ..... 60 Hz**  
**Phase ..... Single-Phase**  
**Power Supply Circuit ..... 20 Amps**  
**Plug/Receptacle ..... NEMA 5-15**

## Circuit Requirements for 240V

This machine can be converted to operate on a 240V power supply (refer to **Voltage Conversion** instructions) that has a verified ground and meets the following requirements:

**Nominal Voltage ..... 240V**  
**Cycle ..... 60 Hz**  
**Phase ..... Single-Phase**  
**Power Supply Circuit ..... 15 Amps**  
**Plug/Receptacle ..... NEMA 6-15**



## Grounding Requirements

This machine **MUST** be grounded. In the event of certain malfunctions or breakdowns, grounding reduces the risk of electric shock by providing a path of least resistance for electric current.

**For 120V operation:** This machine is equipped with a power cord that has an equipment-grounding wire and a grounding plug (see following figure). The plug must only be inserted into a matching receptacle (outlet) that is properly installed and grounded in accordance with all local codes and ordinances.

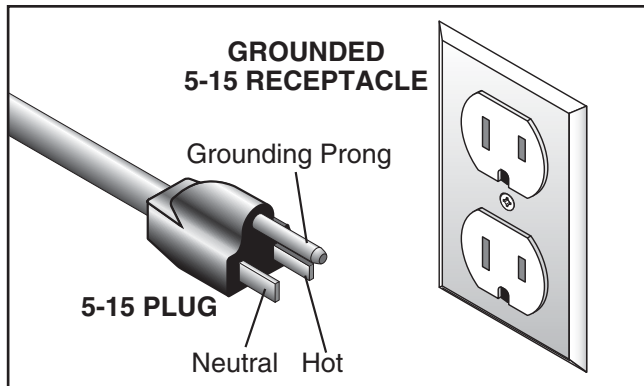

**Figure 1.** Typical 5-15 plug and receptacle.

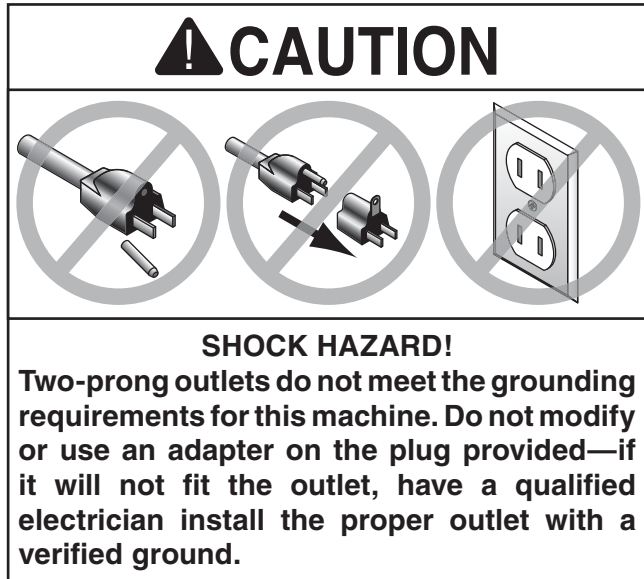

**For 240V operation:** The plug specified under “Circuit Requirements for 240V” on the previous page has a grounding prong that must be attached to the equipment-grounding wire on the included power cord. The plug must only be inserted into a matching receptacle (see following figure) that is properly installed and grounded in accordance with all local codes and ordinances.

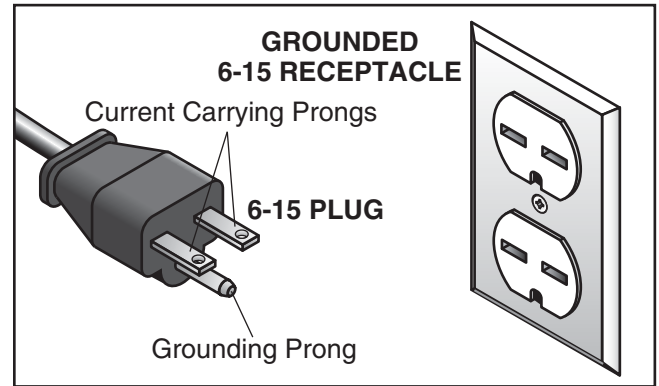

**Figure 2.** Typical 6-15 plug and receptacle.

Improper connection of the equipment-grounding wire can result in a risk of electric shock. The wire with green insulation (with or without yellow stripes) is the equipment-grounding wire. If repair or replacement of the power cord or plug is necessary, do not connect the equipment-grounding wire to a live (current carrying) terminal.

Check with a qualified electrician or service personnel if you do not understand these grounding requirements, or if you are in doubt about whether the tool is properly grounded. If you ever notice that a cord or plug is damaged or worn, disconnect it from power, and immediately replace it with a new one.

## Extension Cords

We do not recommend using an extension cord with this machine. If you must use an extension cord, only use it if absolutely necessary and only on a temporary basis.

Extension cords cause voltage drop, which may damage electrical components and shorten motor life. Voltage drop increases as the extension cord size gets longer and the gauge size gets smaller (higher gauge numbers indicate smaller sizes).

Any extension cord used with this machine must contain a ground wire, match the required plug and receptacle, and meet the following requirements:

- Minimum Gauge Size (for 120V) .....12 AWG**
- Minimum Gauge Size (for 240V) .....14 AWG**
- Maximum Length (Shorter is Better).....50 ft.**



## Voltage Conversion

The voltage conversion **MUST** be performed by an electrician or qualified service personnel.

The voltage conversion procedure consists of rewiring the motor and installing the correct plug. A wiring diagram is provided on the next page for your reference.

**IMPORTANT:** If the diagram included on the motor conflicts with the one on the next page, the motor may have changed since the manual was printed. Use the diagram included on the motor junction box cover instead.

### Items Needed

	Qty
• Phillips Head Screwdriver #2 .....	1
• Electrical Tape.....	As Needed
• Wire Nut (14 AWG x 3) .....	1
• Plug 6-15.....	1

### To convert the Model G0604X/ZX to 240V:

1. DISCONNECT MACHINE FROM POWER!
2. Cut off the included plug.
3. Open the motor junction box, then remove the wire nuts indicated in **Figure 3**.

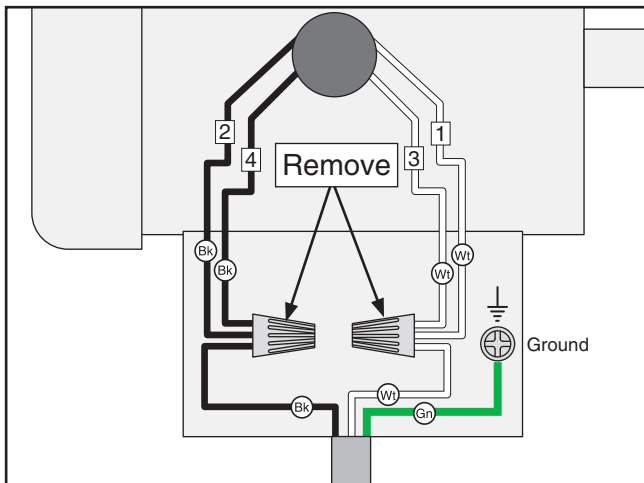

**Figure 3.** Location of wire nuts to be removed.

4. Connect the motor wires, as shown in **Figure 4**, with wire nuts. Once snug, wrap electrical tape around each wire nut and the connected wires, to reduce the likelihood of the wire nut vibrating loose during motor operation.

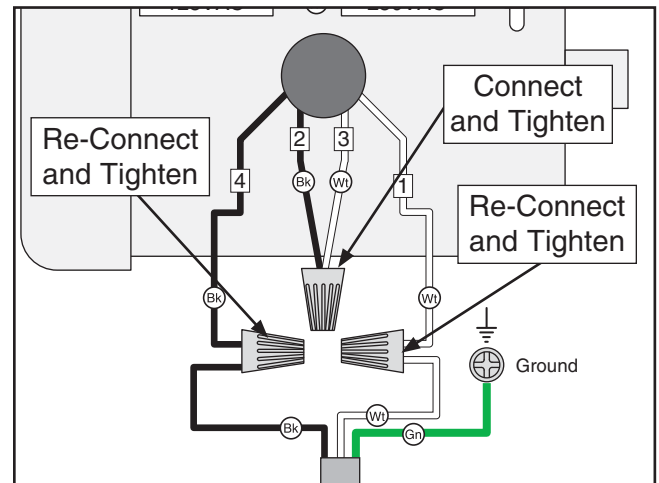

**Figure 4.** Motor wires repositioned for 240V.

5. Close and secure the motor junction box.
6. Install a 6-15 plug on the end of the cord, according to the instructions and wiring diagrams provided by the plug manufacturer.

—If the plug manufacturer did not include instructions, the wiring of a generic NEMA 6-15 plug is illustrated on the next page.



# G0604X/ZX 120V Wiring Diagram

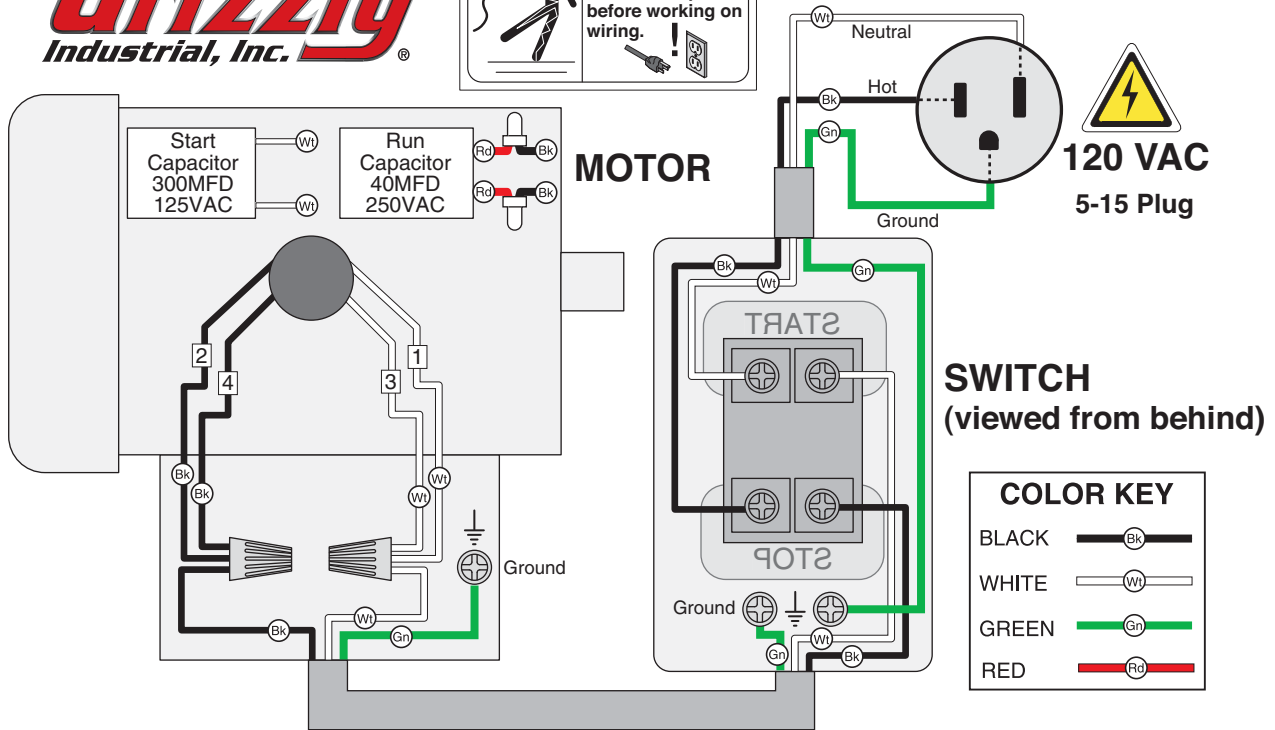

# G0604X/ZX 240V Wiring Diagram

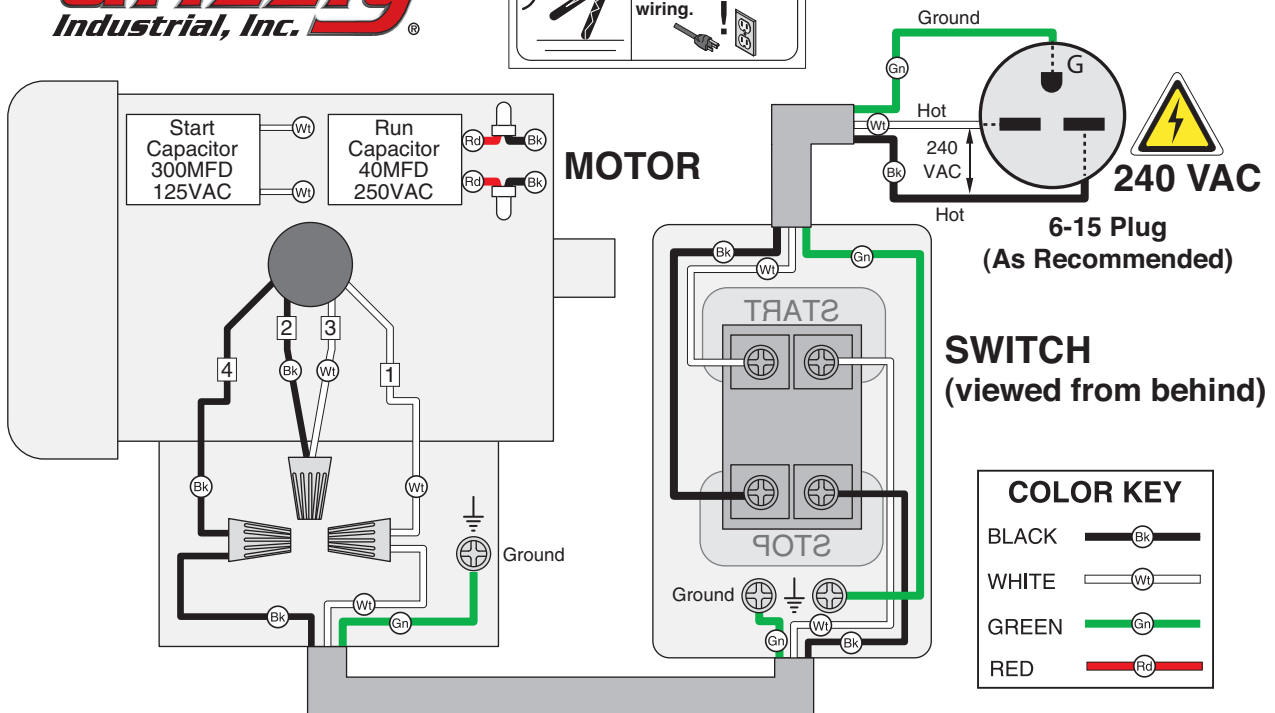

# *grizzly.com*<sup>®</sup>

**TOOL WEBSITE**

Buy Direct and Save with Grizzly<sup>®</sup> – Trusted, Proven and a Great Value!  
~Since 1983~

*Visit Our Website Today For  
Current Specials!*

**ORDER  
24 HOURS A DAY!  
1-800-523-4777**





## MODEL G0604ZX 6" X 56" JOINTER w/SPIRAL CUTTERHEAD MANUAL INSERT

The Model G0604ZX is the same as the Model G0604, except it has a spiral cutterhead and a 1½ HP 110/220V motor. Besides the data sheet, circuit requirements, parts, and wiring diagram in this insert, the content in the Model G0604 owner's manual is the same for both machines. Before operating your new machine, you **MUST** read and understand this insert and the entire Model G0604 manual to reduce the risk of injury from improper use or setup.

*If you have any further questions about this manual insert or the differences between the Model G0604ZX and the Model G0604, contact our Technical Support at (570) 546-9663 or email [techsupport@grizzly.com](mailto:techsupport@grizzly.com).*



COPYRIGHT © SEPTEMBER, 2007 BY GRIZZLY INDUSTRIAL, INC.  
**WARNING: NO PORTION OF THIS MANUAL MAY BE REPRODUCED IN ANY SHAPE  
OR FORM WITHOUT THE WRITTEN APPROVAL OF GRIZZLY INDUSTRIAL, INC.**  
#TR10011 PRINTED IN CHINA



# MACHINE DATA SHEET

Customer Service #: (570) 546-9663 • To Order Call: (800) 523-4777 • Fax #: (800) 438-5901

## MODEL G0604ZX 6" x 56" PARALLELOGRAM BED JOINTER w/SPIRAL CUTTERHEAD

Design Type: ..... Floor Model

### Overall Dimensions:

Table Size ..... 6" W x 55½" L  
Height (from floor to table) ..... 32½"  
Table Length ..... 55½"  
Table Width ..... 6"  
Shipping Weight ..... 352 lbs.  
Net Weight ..... 325 lbs.  
1<sup>st</sup> Box Size ..... 29"L x 18"W x 28"H  
2<sup>nd</sup> Box Size ..... 62"L x 21"W x 14"H  
Stand Footprint ..... 27"W x 20½"D

### Main Specifications:

Maximum Depth of Cut (per pass) ..... ⅛"  
Maximum Width of Cut ..... 6"  
Cutterhead Type ..... Spiral with German-Made Indexable Carbide Inserts  
Cutterhead Diameter ..... 3"  
Cutterhead Speed ..... 4,850 RPM  
Number of Indexable Carbide Inserts ..... 32  
Cuts Per Minute (Effective) ..... 19,400

### Construction:

Tables ..... Precision Ground Cast Iron  
Fence Assembly ..... Cast Iron  
Body Assembly ..... Cast Iron  
Stand ..... Preformed Steel  
Guard ..... Aluminum  
Bearings ..... Shielded and Lubricated

### Motor:

Type ..... TEFC Capacitor Start Induction  
Horsepower ..... 1½ HP  
Phase / Voltage ..... Single-Phase / 110/220V  
Amps ..... 15/7.5A  
Cycle / RPM ..... 60 Hertz / 3450 RPM  
Power Transfer ..... Belt Drive  
Bearings ..... Shielded and Lubricated  
Sound Rating ..... 80 dB

### Features:

Parallelogram Table Adjustment  
Convenient Top Mount Switch Controls with Large OFF Paddle  
Spiral Cutterhead with German-Made Indexable Carbide Inserts  
Fence Stops at 45°, 90°, 135°  
Included 4" Dust Port  
Built-In, Easy-to-Use Mobile Base  
Included Knife Setting Jig and Push Blocks

# CIRCUIT REQUIREMENTS

## 110/220V Operation

### **!WARNING**

Serious personal injury could occur if you connect the machine to power before completing the setup process. **DO NOT** connect the machine to the power until instructed in the G0604 manual in the Test Run section.



### **!WARNING**

Electrocution or fire could result if machine is not grounded and installed in compliance with electrical codes. Compliance **MUST** be verified by a qualified electrician!

### **NOTICE**

The Model G0604ZX is prewired for 110V operation. If you plan to operate your machine at 220V, rewire the motor (see 220V wiring diagram on the following page).

### Full Load Amperage Draw

Motor Draw at 110V (prewired) ..... 15 Amps  
Motor Draw at 220V ..... 7.5 Amps

### Circuit Requirements

You **MUST** connect your machine to a grounded circuit that is rated for the amperage given below. Never replace a circuit breaker on an existing circuit with one of higher amperage without consulting a qualified electrician to ensure compliance with wiring codes. **If you are unsure about the wiring codes in your area or you plan to connect your machine to a shared circuit, consult a qualified electrician.**

110V Circuit.....20 Amps  
220V Circuit..... 15 Amps

### Power Connection Device

The Model G0604ZX comes prewired with a NEMA 5-15 plug to connect the machine to power. If you rewire the motor to 220V, we recommend using the 220V plug and receptacle shown in **Figure 1**.

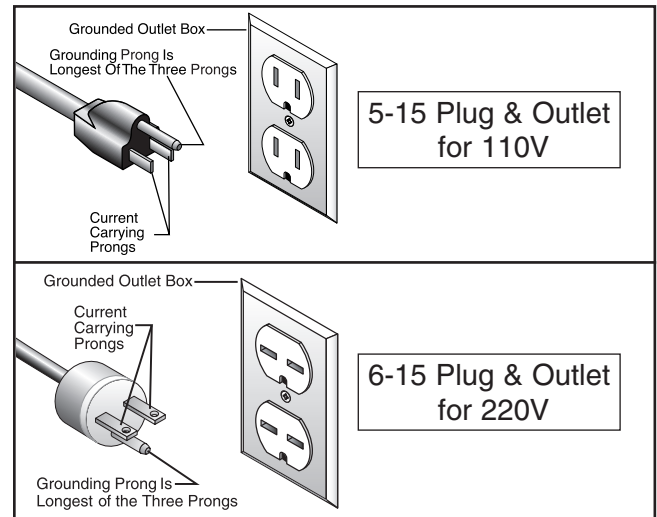

**Figure 1.** Recommended plug types.

### Extension Cords

Using extension cords may reduce the life of the motor. Instead, place the machine near a power source.

**If you must use an extension cord, follow these requirements:**

- For 110V, use at least a 12 gauge cord that does not exceed 50 feet in length.
- For 220V, use at least a 14 gauge cord that does not exceed 50 feet in length.
- The extension cord must have a ground wire and plug pin.



# G0604ZX 110V Wiring Diagram

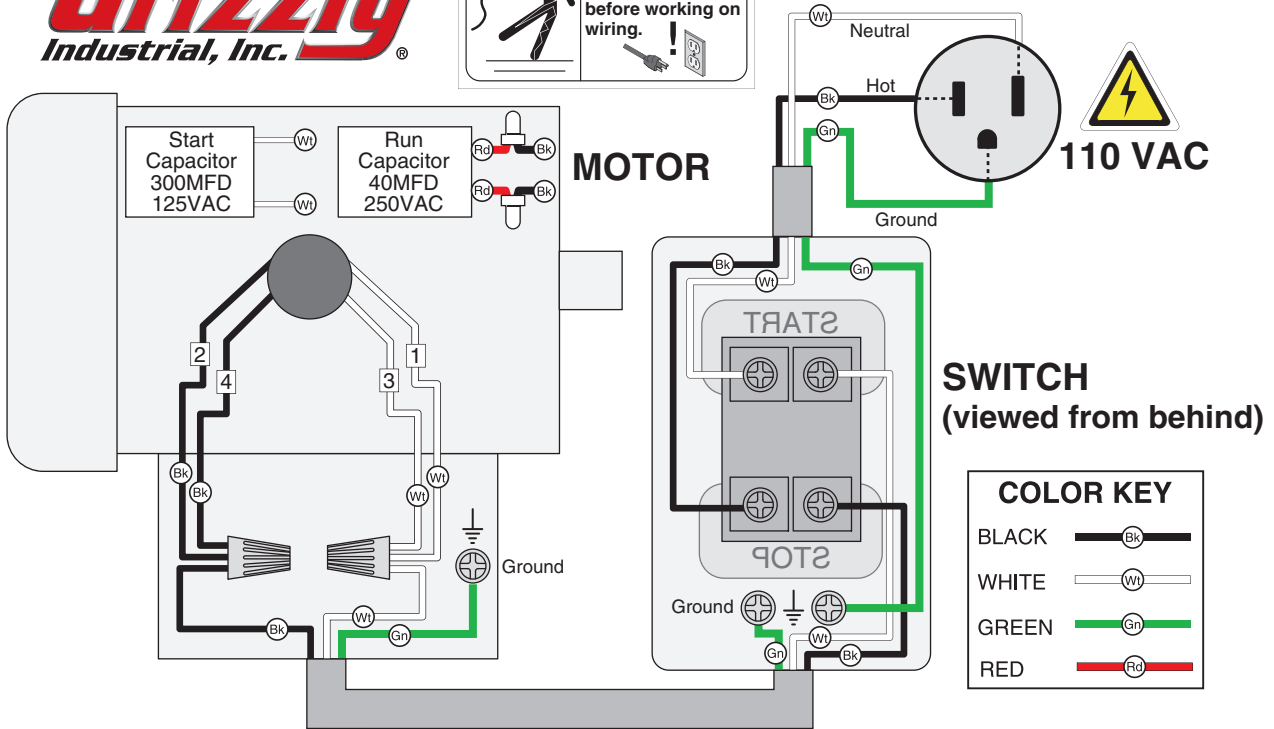

# G0604ZX 220V Wiring Diagram

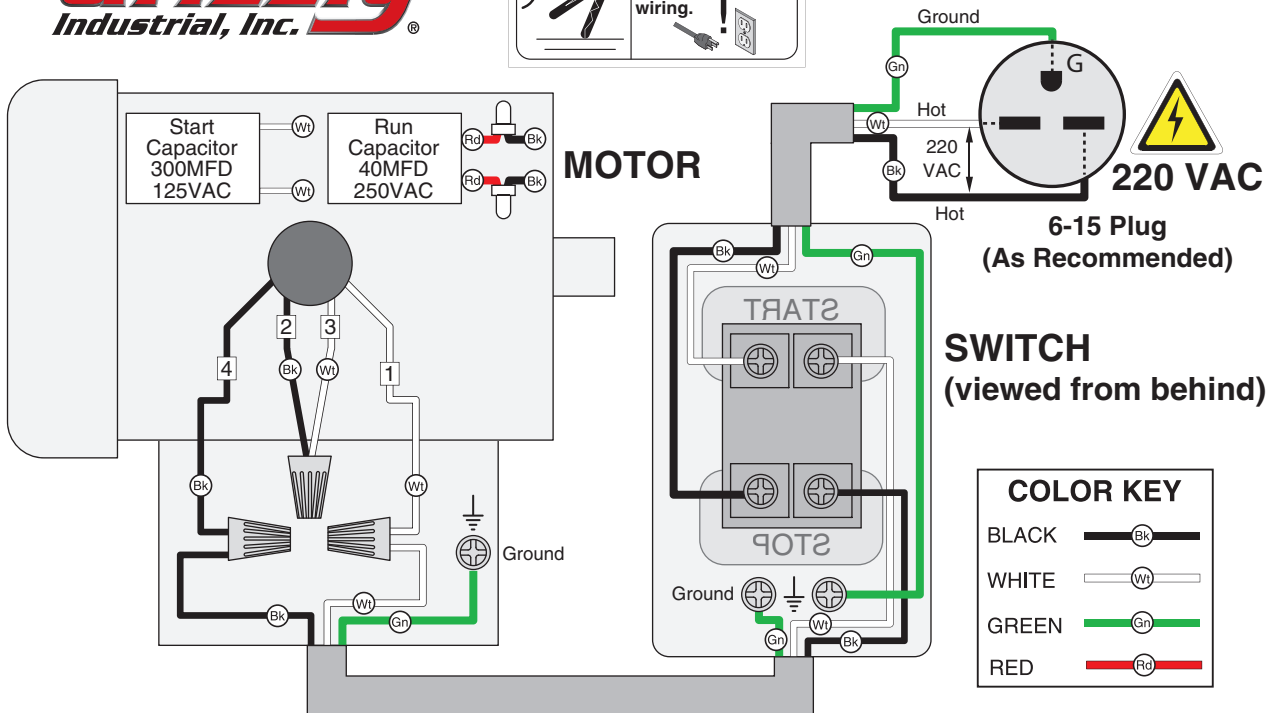

# Jointer Breakdown

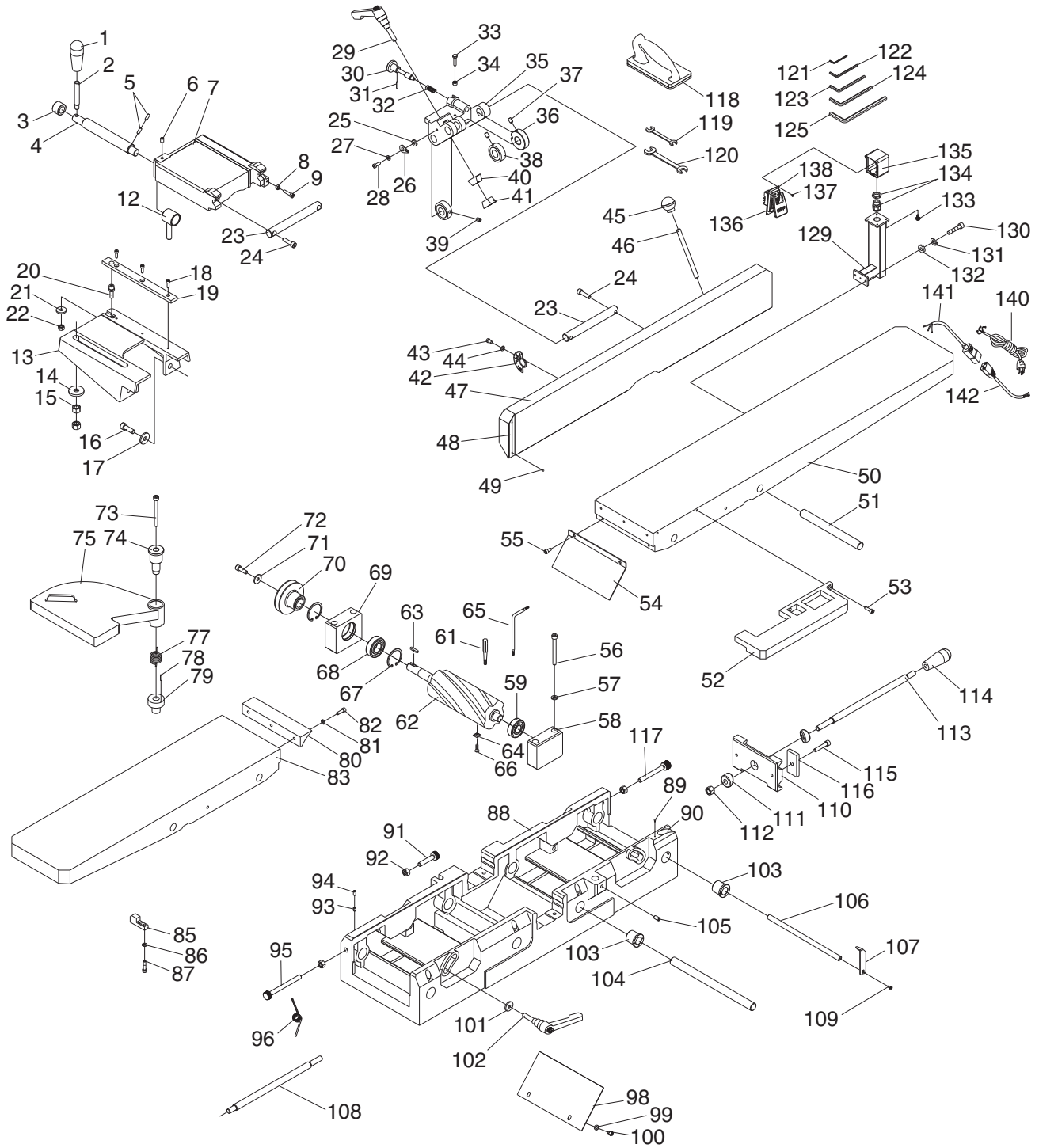

# Jointer Parts List

REF	PART #	DESCRIPTION
1	P0604001	HANDLE 3/8"
2	P0604002	STUD
3	P0604003	BUSHING
4	P0604004	SHAFT
5	PSS11M	SET SCREW M6-1 X 16
6	PSS16M	SET SCREW M8-1.25 X 10
7	P0604007	CARRIAGE
8	PN01M	HEX NUT M6-1
9	PSB06M	CAP SCREW M6-1 X 25
12	P0604012	COLLAR
13	P0604013	SUPPORT
14	PW06M	FLAT WASHER 12MM
15	PN09M	HEX NUT M12-1.75
16	PSB72M	CAP SCREW M10-1.5 X 30
17	PW04M	FLAT WASHER 10MM
18	PSB24M	CAP SCREW M5-.8 X 16
19	P0604019	GIB
20	P0604020	ECCENTRIC
21	PW01M	FLAT WASHER 8MM
22	PN03M	HEX NUT M8-1.25
23	P0604023	SHAFT
24	PSB13M	CAP SCREW M8-1.25 X 30
25	PW03M	FLAT WASHER 6MM
26	P0604026	POINTER
27	PLW03M	LOCK WASHER 6MM
28	PSB115M	BUTTON HD CAP SCR M6-1 X 16
29	P0604029	ADJUSTABLE HANDLE
30	P0604030	INDEX PIN ASSY
31	PRP42M	ROLL PIN 3 X 20
32	P0604032	COMPRESSION SPRING
33	PB10M	HEX BOLT M6-1 X 25
34	PN01M	HEX NUT M6-1
35	P0604035	SWIVEL
36	P0604036	COLLAR
37	PSS16M	SET SCREW M8-1.25 X 10
38	P0604038	LOCK
39	PSS14M	SET SCREW M8-1.25 X 12
40	P0604040	UPPER CLAMP
41	P0604041	LOWER CLAMP
42	P0604042	SCALE
43	PS68M	PHLP HD SCR M6-1 X 10
44	PW03M	FLAT WASHER 6MM
45	P0604045	BALL KNOB 3/8"
46	P0604046	STUD
47	P0604047	FENCE
48	P0604048	SCALE
49	P0604049	RIVET

REF	PART #	DESCRIPTION
50	P0604050	TABLE RH
51	P0604051	TABLE SHAFT
52	P0604052	RABBETING TABLE EXT
53	PSB02M	CAP SCREW M6-1 X 20
54	P0604054	CHIP DEFLECTOR
55	PSB33M	CAP SCREW M5-.8 X 12
56	PSB148M	CAP SCREW M8-1.25 X 80
57	PLW04M	LOCK WASHER 8MM
58	P0604058	BEARING BLOCK LEFT
59	P6004	BALL BEARING 6004ZZ
61	P0452Z001	DRIVER BIT TORX T20
62	P0452Z011	SPIRAL CUTTERHEAD 6"
63	PK74M	KEY 6 X 6 X 35
64	P0452Z002	INDEXABLE INSERT 14 x 14 x 2
65	P0452Z009	L-WRENCH TORX T20
66	PFH35M	FLAT HD TORX SCR T20 M6-1 X 15
67	PR24M	INT RETAINING RING 42MM
68	P6004	BALL BEARING 6004ZZ
69	P0604069	BEARING BLOCK RIGHT
70	P0604070	CUTTERHEAD PULLEY
71	PW01M	FLAT WASHER 8MM
72	PSB31M	CAP SCREW M8-1.25 X 25
73	PSB148M	CAP SCREW M8-1.25 X 80
74	P0604074	GUARD CLAMP
75	P0604075	CUTTERHEAD GUARD
77	P0604077	TORSION SPRING
78	PRP02M	ROLL PIN 3 X 16
79	P0604079	SUPPORT
80	P0604080	TABLE LIP
81	PW02M	FLAT WASHER 5MM
82	PSB24M	CAP SCREW M5-.8 X 16
83	P0604083	TABLE LH
85	P0604085	BUMPER
86	PW03M	FLAT WASHER 6MM
87	PSB07M	CAP SCREW M6-1 X 30
88	P0604088	BASE
89	P0604089	RIVET
90	P0604090	SCALE
91	P0490091	SHORT ADJUSTING SCREW
92	PN02M	HEX NUT M10-1.5
93	PSS01M	SET SCREW M6-1 X 10
94	PSS01M	SET SCREW M6-1 X 10
95	P0490095	LONG ADJUSTING SCREW
96	P0604096	TORSION SPRING
98	P0604098	CHIPBREAKER
99	PW03M	FLAT WASHER 6MM



# Jointer Parts List, Continued

REF	PART #	DESCRIPTION
100	PB02M	HEX BOLT M6-1 X 12
101	PW01M	FLAT WASHER 8MM
102	P0604102	ADJUSTABLE HANDLE
103	P0604103	ECCENTRIC BUSHING
104	P0604104	TABLE SHAFT
105	PSS14M	SET SCREW M8-1.25 X 12
106	P0604106	TABLE SHAFT
107	P0604107	POINTER
108	P0604108	LEVER
109	PFH07M	FLAT HD SCR M5-.8 X 10
110	P0604110	PIVOT BRACKET
111	P0604111	ADJUSTING BLOCK
112	PN09M	HEX NUT M12-1.75
113	P0604113	LEVER
114	P0604001	HANDLE 3/8"
115	PSB12M	CAP SCREW M8-1.25 X 40
116	P0604116	CLAMP PLATE
117	P0604117	MEDIUM ADJUSTMENT SCR
118	P0604118	PUSH BLOCK
119	P0604119	OPEN END WRENCH 8/10MM

REF	PART #	DESCRIPTION
120	P0604120	OPEN END WRENCH 12/14MM
121	PAW02.5M	HEX WRENCH 2.5MM
122	PAW04M	HEX WRENCH 4MM
123	PAW05M	HEX WRENCH 5MM
124	PAW06M	HEX WRENCH 6MM
125	PAW08M	HEX WRENCH 8MM
129	P0604129	SWITCH PEDESTAL
130	PSB31M	CAP SCREW M8-1.25 X 25
131	PLW04M	LOCK WASHER 8MM
132	PW01M	FLAT WASHER 8MM
133	P0604133	FLANGE BOLT M6-1 X 16
134	P0604134	BALL STRAIN RELIEF 13.5MM
135	P0604135	SWITCH BOX
136	P0604136	SWITCH ASSEMBLY
137	PHTEK4M	TAP SCREW M4 X 8
138	P0604138	SWITCH BRACKET
140	P0452075A-5	POWER CORD
141	P0452075A-6	SWITCH CORD
142	P0452075A-7	MOTOR CORD



# Stand Breakdown

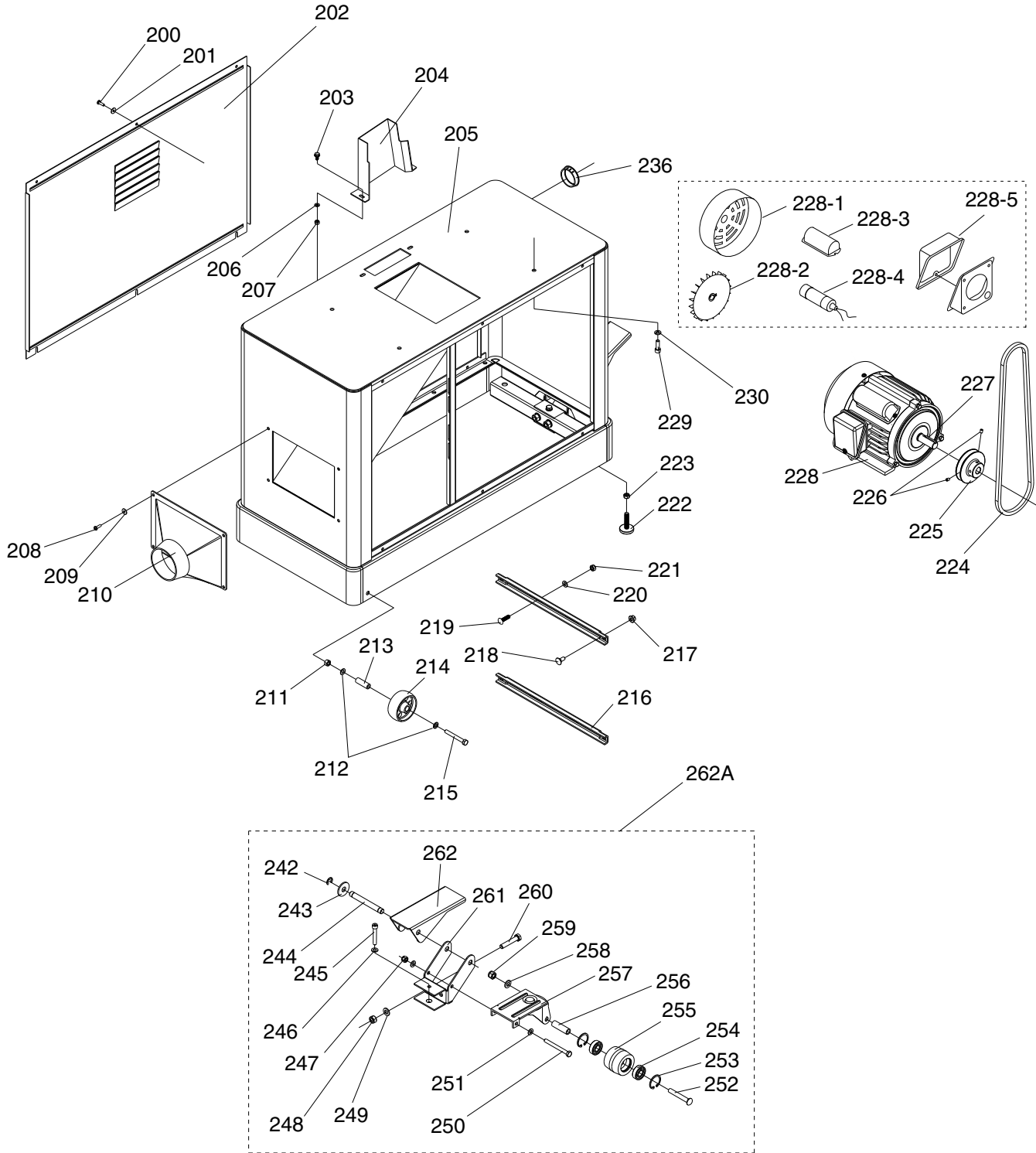

# Stand Parts List

REF	PART #	DESCRIPTION
200	PS40M	PHLP HD SCR M5-.8 X 16
201	PW02M	FLAT WASHER 5MM
202	P0604202	PANEL
203	PFS02M	FLANGE SCREW M6-1 X 12
204	P0604204	BELT GUARD
205	P0604205	CABINET STAND
206	PW03M	FLAT WASHER 6MM
207	PN01M	HEX NUT M6-1
208	PS40M	PHLP HD SCR M5-.8 X 16
209	PW02M	FLAT WASHER 5MM
210	P0604210	DUST PORT
211	PN03M	HEX NUT M8-1.25
212	PW01M	FLAT WASHER 8MM
213	P0604213	SLEEVE
214	P0604214	WHEEL
215	PB86M	HEX BOLT M8-1.25 X 65
216	P0604216	MOTOR BRACKET
217	P0604217	FLANGE NUT 5/16-18
218	PCB05	CARRIAGE BOLT 5/16-18 X 3/4
219	PCB11	CARRIAGE BOLT 5/16-18 X 1
220	PW07	FLAT WASHER 5/16
221	P0604221	FLANGE NUT 5/16-18
222	P0604222	FOOT
223	PN08	HEX NUT 3/8-16
224	PVA40	V-BELT A-40 4L400
225	P0604225	MOTOR PULLEY
226	PSS02M	SET SCREW M6-1 X 6
227	PK12M	KEY 5 X 5 X 30
228	P0452Z224	MOTOR 1.5HP, 110V/220V, 1-PHASE
228-1	P0452Z224-1	FAN COVER

REF	PART #	DESCRIPTION
228-2	P0452Z224-2	MOTOR FAN
228-3	P0452Z224-3	CAPACITOR COVER
228-4	P0452Z224-4	CAPACITOR 200M 125V 40 x 80MM
228-5	P0452Z224-5	JUNCTION BOX
229	PSB31M	CAP SCREW M8-1.25 X 25
230	PLW04M	LOCK WASHER 8MM
236	P0604236	STRAIN RELIEF
242	PR16M	EXT RETAINING RING 9MM
243	P0604243	SPECIAL WASHER 13MM
244	P0604244	SHAFT
245	PSB05M	CAP SCREW M8-1.25 X 50
246	PW01M	FLAT WASHER 8MM
247	PN03M	HEX NUT M8-1.25
248	PN02M	HEX NUT M10-1.5
249	PW04M	FLAT WASHER 10MM
250	PB45M	HEX BOLT M8-1.25 X 100
251	PW01M	FLAT WASHER 8MM
252	P0604252	SPECIAL BOLT
253	PR21M	INT RETAINING RING 35MM
254	P6202	BALL BEARING 6202ZZ
255	P0604255	TROLLEY WHEEL
256	P0604256	SLEEVE
257	P0604257	TROLLEY BRACKET
258	PW04M	FLAT WASHER 10MM
259	PN02M	HEX NUT M10-1.5
260	PB144M	HEX BOLT M10-1.5 X 55
261	P0604261	PEDAL BRACKET
262	P0604262	PEDAL
262A	P0604ZX262A	COMPLETE PEDAL ASSY



# Labels Breakdown & Parts List

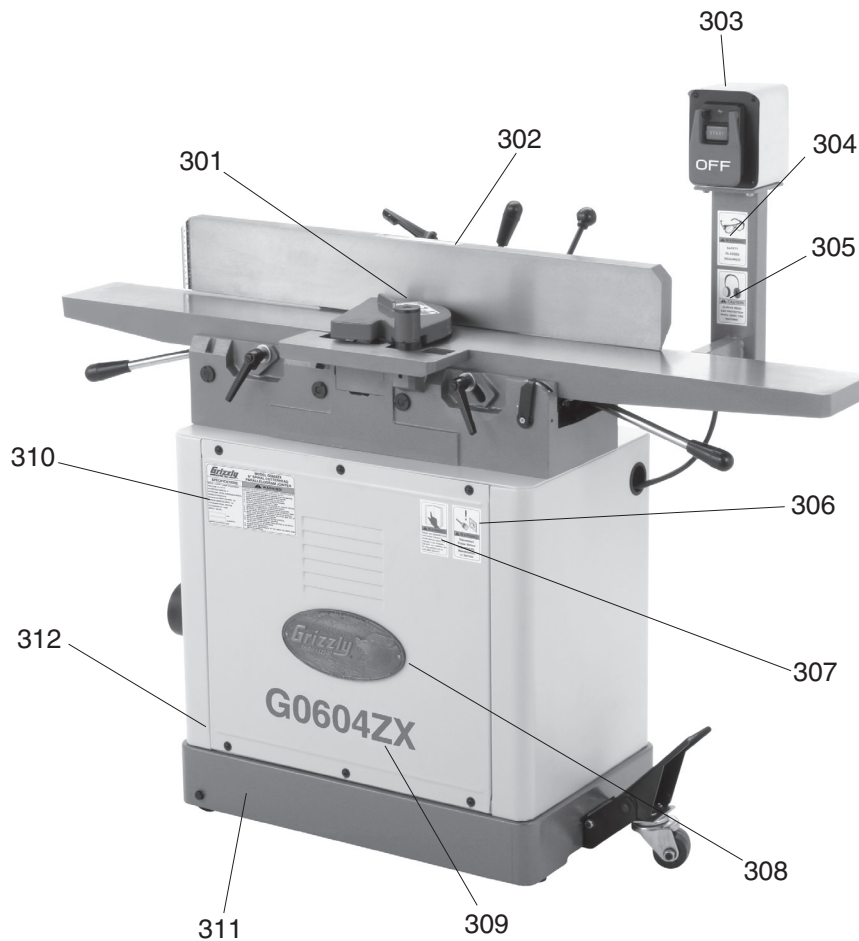

REF	PART #	DESCRIPTION
301	PLABEL-29	CUTTERHEAD GUARD LABEL
302	P0604302	CUTTERHEAD WARNING LABEL
303	PLABEL-14	ELECTRICITY LABEL
304	PLABEL-11	SAFETY GLASSES LABEL
305	PLABEL-15	EAR PROTECTION LABEL
306	PLABEL-26	DISCONNECT POWER LABEL

REF	PART #	DESCRIPTION
307	PLABEL-12A	READ MANUAL LABEL
308	P0604308	GRIZZLY NAMEPLATE
309	P0604ZX309	MODEL # LABEL
310	P0604ZX310	MACHINE ID LABEL
311	PPAINT-1	"GRIZZLY GREEN" TOUCH-UP PAINT
312	PPAINT-11	"PUTTY" TOUCH-UP PAINT

## WARNING

Safety labels warn about machine hazards and ways to prevent injury. The owner of this machine **MUST** maintain the original location and readability of the labels on the machine. If any label is removed or becomes unreadable, **REPLACE** that label before using the machine again. Contact Grizzly at (800) 523-4777 or [www.grizzly.com](http://www.grizzly.com) to order new labels.



# G0604ZX JOINTER ACCESSORIES

## G3640—Power Twist® V-Belt - ½" x 48"

Smooth running with less vibration and noise than solid belts. The Power Twist® V-belt can be customized in minutes to any size—just add or remove sections to fit your needs. Size: ½" x 48"; replaces all "A" sized V-belts. Requires one Power Twist® V-belt to replace the stock V-belt on the Model G0604ZX.

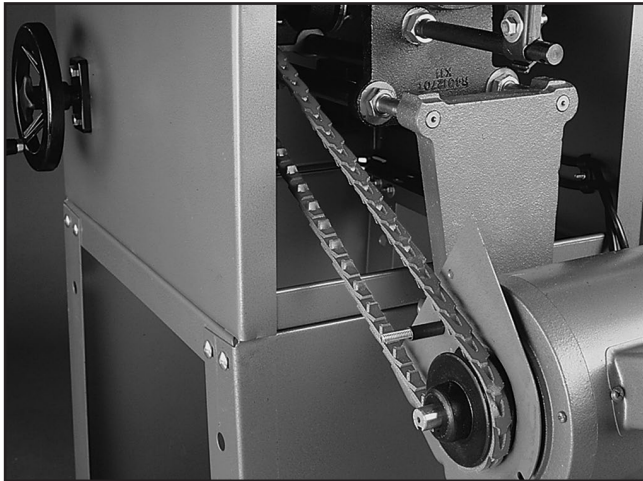

Figure 2. G3640 Power Twist® V-Belt.

## H9218—6" Byrd® Shelix Cutterhead

Made in the USA by Byrd, this indexable carbide insert cutterhead is the best money can buy—period! The inserts are not only placed in a spiral pattern, they are also positioned at an angle so the shearing action leaves a glassy smooth cut on the toughest and most figured woods. Comes with 5 extra replacement inserts. Very nice upgrade!

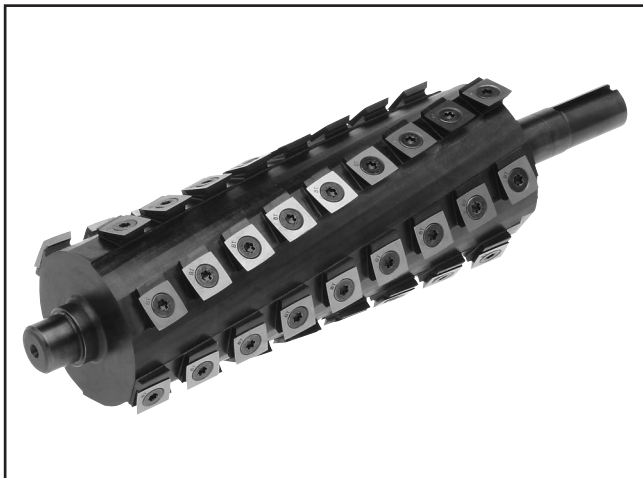

Figure 3. H9218 Byrd Shelix Cutterhead.

## T21348—10 pk. of Carbide Inserts 14x14x2mm

## H1411—PowerHands™ Safety Stick

This safety push stick features interchangeable traction treads; one for flat stock, and one for pressing against table and fence. It also has a spring loaded push-pin for full workpiece contact. Made in the USA.



Figure 4. H1411 PowerHands™ Safety Stick.

## G5562—SLIPIT® 1 Qt. Gel

## G5563—SLIPIT® 12 oz Spray

## G2871—Boeshield® T-9 12 oz Spray

## G2870—Boeshield® T-9 4 oz Spray

## H3788—G96® Gun Treatment 12 oz Spray

## H3789—G96® Gun Treatment 4.5 oz Spray



Figure 5. Recommended products for protecting unpainted cast iron/steel parts on machinery.

# *grizzly.com*

**TOOL WEBSITE**

Buy Direct and Save with Grizzly® – Trusted, Proven and a Great Value!

*Visit Our Website Today And Discover  
Why Grizzly® Is The Industry Leader!*

- SECURE ORDERING
- ORDERS SHIPPED WITHIN 24 HOURS
- E-MAIL RESPONSE WITHIN ONE HOUR

-OR-

Call Today For A **FREE**  
Full Color Catalog

**1-800-523-4777**



# *Grizzly* *Industrial, Inc.*®

## MODEL G0604 6" X 56" JOINTER OWNER'S MANUAL



COPYRIGHT © JUNE, 2006 BY GRIZZLY INDUSTRIAL, INC.  
**WARNING: NO PORTION OF THIS MANUAL MAY BE REPRODUCED IN ANY SHAPE  
OR FORM WITHOUT THE WRITTEN APPROVAL OF GRIZZLY INDUSTRIAL, INC.**  
#TR8349 PRINTED IN CHINA.



## **WARNING!**

**This manual provides critical safety instructions on the proper setup, operation, maintenance and service of this machine/equipment.**

**Failure to read, understand and follow the instructions given in this manual may result in serious personal injury, including amputation, electrocution or death.**

**The owner of this machine/equipment is solely responsible for its safe use. This responsibility includes but is not limited to proper installation in a safe environment, personnel training and usage authorization, proper inspection and maintenance, manual availability and comprehension, application of safety devices, blade/cutter integrity, and the usage of personal protective equipment.**

**The manufacturer will not be held liable for injury or property damage from negligence, improper training, machine modifications or misuse.**



## **WARNING!**

**Some dust created by power sanding, sawing, grinding, drilling, and other construction activities contains chemicals known to the State of California to cause cancer, birth defects or other reproductive harm. Some examples of these chemicals are:**

- **Lead from lead-based paints.**
- **Crystalline silica from bricks, cement and other masonry products.**
- **Arsenic and chromium from chemically-treated lumber.**

**Your risk from these exposures varies, depending on how often you do this type of work. To reduce your exposure to these chemicals: Work in a well ventilated area, and work with approved safety equipment, such as those dust masks that are specially designed to filter out microscopic particles.**

# Table of Contents

- INTRODUCTION..... 3**
  - Foreword ..... 3
  - Contact Info ..... 3
  - Machine Data Sheet..... 4
  - Identification ..... 5
- SECTION 1: SAFETY ..... 6**
  - Safety Instructions for Machinery ..... 6
  - Additional Safety for Jointers ..... 8
- SECTION 2: CIRCUIT REQUIREMENTS ..... 9**
  - 110V Operation ..... 9
- SECTION 3: SETUP ..... 10**
  - Setup Safety..... 10
  - Items Needed for Setup ..... 10
  - Unpacking ..... 10
  - Inventory..... 11
  - Hardware Recognition Chart..... 12
  - Cleanup ..... 13
  - Site Considerations ..... 13
  - Wheel Assembly ..... 13
  - Jointer..... 14
  - V-Belt..... 14
  - Checking Outfeed Table Height..... 15
  - Extension Table ..... 16
  - Fence ..... 17
  - Cutterhead Guard ..... 18
  - Pedestal Switch..... 18
  - Knife Setting Jig ..... 19
  - Dust Port ..... 19
  - Test Run..... 20
  - Recommended Adjustments ..... 20
- SECTION 4: OPERATIONS ..... 21**
  - Operation Safety ..... 21
  - Basic Controls ..... 21
  - Stock Inspection and Requirements ..... 22
  - Squaring Stock..... 23
  - Surface Planing..... 24
  - Edge Jointing ..... 25
  - Bevel Cutting..... 26
- SECTION 5: ACCESSORIES ..... 27**
- SECTION 6: MAINTENANCE ..... 30**
  - Schedule ..... 30
  - V-Belt..... 30
  - Cleaning ..... 30
  - Lubrication..... 30

<b>SECTION 7: SERVICE .....</b>	<b>31</b>
Troubleshooting Guide .....	31
Inspecting Knives .....	33
Adjusting/Replacing Knives.....	33
Checking/Adjusting Table Parallelism.....	36
Setting Outfeed Table Height.....	38
Setting Infeed Table .....	39
Calibrating Depth Scale .....	40
Setting Fence Stops.....	40
Wiring Diagram .....	42
Electrical Components .....	42
Jointer Parts Breakdown .....	43
Jointer Parts List .....	44
Stand/Motor Parts Breakdown .....	46
Stand/Motor Parts List.....	47
Warning Label Parts List.....	48
<b>WARRANTY AND RETURNS .....</b>	<b>49</b>

# INTRODUCTION

---

---

## Foreword

---

---

We are proud to offer the Model G0604 6" X 56" Jointer. This machine is part of a growing Grizzly family of fine woodworking machinery. When used according to the guidelines set forth in this manual, you can expect years of trouble-free, enjoyable operation and proof of Grizzly's commitment to customer satisfaction.

We are pleased to provide this manual with the Model G0604. It was written to guide you through assembly, review safety considerations, and cover general operating procedures. It represents our effort to produce the best documentation possible.

The specifications, drawings, and photographs illustrated in this manual represent the Model G0604 as supplied when the manual was prepared. However, owing to Grizzly's policy of continuous improvement, changes may be made at any time with no obligation on the part of Grizzly. For your convenience, we always keep current Grizzly manuals available on our website at **www.grizzly.com**. Any updates to your machine will be reflected in these manuals as soon as they are complete. Visit our site often to check for the latest updates to this manual!

## Contact Info

---

---

If you have any comments regarding this manual, please write to us at the address below:

Grizzly Industrial, Inc.  
c/o Technical Documentation Manager  
P.O. Box 2069  
Bellingham, WA 98227-2069

We stand behind our machines. If you have any service questions or parts requests, please call or write us at the location listed below.

Grizzly Industrial, Inc.  
1203 Lycoming Mall Circle  
Muncy, PA 17756  
Phone: (570) 546-9663  
Fax: (800) 438-5901  
E-Mail: [techsupport@grizzly.com](mailto:techsupport@grizzly.com)  
Web Site: <http://www.grizzly.com>





# MACHINE DATA SHEET

Customer Service #: (570) 546-9663 • To Order Call: (800) 523-4777 • Fax #: (800) 438-5901

## MODEL G0604 6" X 56" Jointer

**Design Type:** ..... Floor Model

**Overall Dimensions:**

Table Size ..... 6" W x 55½" L  
 Height (from floor to table) ..... 32½"  
 Table Length ..... 55½"  
 Table Width ..... 6"  
 Shipping Weight ..... 347 lbs.  
 Net Weight ..... 320 lbs.  
 1<sup>st</sup> Box Size ..... 29"L x 18"W x 28"H  
 2<sup>nd</sup> Box Size ..... 62"L x 21"W x 14"H  
 Stand Footprint ..... 27"W x 20½"D  
 Cutterhead ..... 4-Knife  
 Cutterhead Diameter ..... 3"  
 Cutterhead Knife Size ..... 6" x ¾" x ⅛"

**Capacities:**

Maximum Depth of Cut (per pass) ..... ⅛"  
 Maximum Width of Cut ..... 6"  
 Cutterhead Speed ..... 4850 RPM  
 Cuts Per Minute ..... 19,400

**Construction:**

Tables ..... Precision Ground Cast Iron  
 Fence Assembly ..... Cast Iron  
 Body Assembly ..... Cast Iron  
 Stand ..... Preformed Steel  
 Guard ..... Aluminum  
 Bearings ..... Shielded and Lubricated

**Motor:**

Type ..... TEFC Capacitor Start Induction  
 Horsepower ..... 1 HP  
 Phase / Voltage ..... Single-Phase / 110V  
 Amps ..... 13A  
 Cycle / RPM ..... 60 Hertz / 3450 RPM  
 Power Transfer ..... Belt Drive  
 Bearings ..... Shielded and Lubricated  
 Sound Rating ..... 80 dB

**Features:**

..... Parallelogram Table Adjustment  
 ..... Top Mount Switch Controls  
 ..... Fence Stops at 45°, 90°, 135°  
 ..... Included 4" Dust Port  
 ..... Included Push Blocks  
 ..... Included Knife Setting Jig

*Specifications, while deemed accurate, are not guaranteed.*



# Identification



- A. Outfeed Table
- B. Fence
- C. Fence Lock
- D. Fence Tilt Lock
- E. Cutterhead Guard
- F. Fence Tilt Handle
- G. Control Panel
- H. Infeed Table
- I. Infeed Table Adjustment Lever
- J. Mobile Base Lock
- K. Depth Scale
- L. Infeed Table Lock
- M. Outfeed Table Lock
- N. Outfeed Table Adjustment Lever



# SECTION 1: SAFETY

## **WARNING**

### **For Your Own Safety, Read Instruction Manual Before Operating this Machine**

The purpose of safety symbols is to attract your attention to possible hazardous conditions. This manual uses a series of symbols and signal words which are intended to convey the level of importance of the safety messages. The progression of symbols is described below. Remember that safety messages by themselves do not eliminate danger and are not a substitute for proper accident prevention measures.

 **DANGER** Indicates an imminently hazardous situation which, if not avoided, **WILL** result in death or serious injury.

 **WARNING** Indicates a potentially hazardous situation which, if not avoided, **COULD** result in death or serious injury.

 **CAUTION** Indicates a potentially hazardous situation which, if not avoided, **MAY** result in minor or moderate injury. It may also be used to alert against unsafe practices.

**NOTICE** This symbol is used to alert the user to useful information about proper operation of the machine.

## **WARNING**

### **Safety Instructions for Machinery**

- 1. READ THROUGH THE ENTIRE MANUAL BEFORE STARTING MACHINERY.** Machinery presents serious injury hazards to untrained users.
- 2. ALWAYS USE ANSI APPROVED SAFETY GLASSES WHEN OPERATING MACHINERY.** Everyday eyeglasses only have impact resistant lenses—they are NOT safety glasses.
- 3. ALWAYS WEAR AN ANSI APPROVED RESPIRATOR WHEN OPERATING MACHINERY THAT PRODUCES DUST.** Wood dust is a carcinogen and can cause cancer and severe respiratory illnesses.
- 4. ALWAYS USE HEARING PROTECTION WHEN OPERATING MACHINERY.** Machinery noise can cause permanent hearing damage.
- 5. WEAR PROPER APPAREL. DO NOT** wear loose clothing, gloves, neckties, rings, or jewelry which may get caught in moving parts. Wear protective hair covering to contain long hair and wear non-slip footwear.
- 6. NEVER OPERATE MACHINERY WHEN TIRED, OR UNDER THE INFLUENCE OF DRUGS OR ALCOHOL.** Be mentally alert at all times when running machinery.



# WARNING

## Safety Instructions for Machinery

7. **ONLY ALLOW TRAINED AND PROPERLY SUPERVISED PERSONNEL TO OPERATE MACHINERY.** Make sure operation instructions are safe and clearly understood.
8. **KEEP CHILDREN AND VISITORS AWAY.** Keep all children and visitors a safe distance from the work area.
9. **MAKE WORKSHOP CHILD PROOF.** Use padlocks, master switches, and remove start switch keys.
10. **NEVER LEAVE WHEN MACHINE IS RUNNING.** Turn power **OFF** and allow all moving parts to come to a complete stop before leaving machine unattended.
11. **DO NOT USE IN DANGEROUS ENVIRONMENTS.** DO NOT use machinery in damp, wet locations, or where any flammable or noxious fumes may exist.
12. **KEEP WORK AREA CLEAN AND WELL LIT.** Clutter and dark shadows may cause accidents.
13. **USE A GROUNDED EXTENSION CORD RATED FOR THE MACHINE AMPERAGE.** Undersized cords overheat and lose power. Replace extension cords if they become damaged.
14. **ALWAYS DISCONNECT FROM POWER SOURCE BEFORE SERVICING MACHINERY.** Make sure switch is in OFF position before reconnecting.
15. **MAINTAIN MACHINERY WITH CARE.** Keep blades sharp and clean for best and safest performance. Follow instructions for lubricating and changing accessories.
16. **MAKE SURE GUARDS ARE IN PLACE AND WORK CORRECTLY BEFORE USING MACHINERY.**
17. **REMOVE ADJUSTING KEYS AND WRENCHES.** Make a habit of checking for keys and adjusting wrenches before turning machinery **ON**.
18. **CHECK FOR DAMAGED PARTS BEFORE USING MACHINERY.** Check for binding and alignment of parts, broken parts, part mounting, loose bolts, and any other conditions that may affect machine operation. Repair or replace damaged parts.
19. **USE RECOMMENDED ACCESSORIES.** Refer to the instruction manual for recommended accessories. The use of improper accessories may cause risk of injury.
20. **DO NOT FORCE MACHINERY.** Work at the speed for which the machine or accessory was designed.
21. **SECURE WORKPIECE.** Use clamps or a vise to hold the workpiece when practical. A secured workpiece protects your hands and frees both hands to operate the machine.
22. **DO NOT OVERREACH.** Keep proper footing and balance at all times.
23. **MANY MACHINES WILL EJECT THE WORKPIECE TOWARD THE OPERATOR.** Know and avoid conditions that cause the workpiece to "kickback."
24. **ALWAYS LOCK MOBILE BASES (IF USED) BEFORE OPERATING MACHINERY.**
25. **BE AWARE THAT CERTAIN WOODS MAY CAUSE AN ALLERGIC REACTION** in people and animals, especially when exposed to fine dust. Make sure you know what type of wood dust you will be exposed to and always wear an approved respirator.



# **WARNING**

## **Additional Safety for Jointers**

- 1. JOINTER KICKBACK.** "Kickback" is when the workpiece is thrown off the jointer table by the force of the cutterhead. Always use push blocks and safety glasses to reduce the likelihood of injury from kickback. If you do not understand what kickback is, or how it occurs, DO NOT operate this machine.
- 2. OUTFEED TABLE ALIGNMENT.** Keep the top surface of the outfeed table aligned with the knives at top dead center (the highest point during rotation) to avoid kickback and personal injuries.
- 3. PUSH BLOCKS.** Always use push blocks whenever surface planing. Never pass your hands directly over the cutterhead without a push block.
- 4. WORKPIECE SUPPORT.** Supporting the workpiece adequately at all times while cutting is crucial for making safe cuts and avoiding injury. Never attempt to make a cut with an unstable workpiece.
- 5. USING GOOD STOCK.** Jointing safety begins with your lumber. Inspect your stock carefully before you feed it over the cutterhead. Never joint a board that has loose knots, nails, or staples. If you have any doubts about the stability or structural integrity of your stock, DO NOT joint it!
- 6. KICKBACK ZONE.** The "kickback zone" is the path directly through the end of the infeed table. Never stand or allow others to stand in this area during operation.
- 7. MAXIMUM CUTTING DEPTH.** The maximum cutting depth for one pass is  $\frac{1}{8}$ ". Never attempt any single cut deeper!
- 8. JOINTING WITH THE GRAIN.** Jointing against the grain or jointing end grain is dangerous and could produce chatter or excessive chip out. Always joint with the grain.
- 9. GUARDS IN PLACE.** All operations must be performed with the guard in place.
- 10. PROPER CUTTING.** When cutting, always keep the workpiece moving toward the outfeed table until the workpiece has passed completely over the cutterhead. Never back the work toward the infeed table.
- 11. SAFE KNIFE PROJECTION.** Knives should never be set in the cutterhead so they project more than 0.125" ( $\frac{1}{8}$ "). Incorrectly set knives may come loose during operation, may become damaged, or may damage the cutterhead.
- 12. MOBILE BASE.** Always lock the mobile base wheel before operating.

### **WARNING**

Like all machines there is danger associated with the Model G0604. Accidents are frequently caused by lack of familiarity or failure to pay attention. Use this machine with respect and caution to lessen the possibility of operator injury. If normal safety precautions are overlooked or ignored, serious personal injury may occur.

### **CAUTION**

No list of safety guidelines can be complete. Every shop environment is different. Always consider safety first, as it applies to your individual working conditions. Use this and other machinery with caution and respect. Failure to do so could result in serious personal injury, damage to equipment, or poor work results.



# SECTION 2: CIRCUIT REQUIREMENTS

## 110V Operation

### **⚠️ WARNING**

**Serious personal injury could occur if you connect the machine to the power source before you have completed the set up process. DO NOT connect the machine to the power source until instructed to do so.**

### Amperage Draw

The Model G0604 motor draws the following amps under maximum load:

Maximum Load..... 13 Amps

### Circuit Requirements

We recommend connecting this machine to a dedicated circuit with a verified ground, using the circuit size given below. Never replace a circuit breaker with one of higher amperage without consulting a qualified electrician to ensure compliance with wiring codes. **If you are unsure about the wiring codes in your area or you plan to connect your machine to a shared circuit, you may create a fire hazard—consult a qualified electrician to reduce this risk.**

Recommended Circuit Size..... 15 Amps

### Plug/Receptacle Type

Included Plug/Receptacle ..... NEMA 5-15

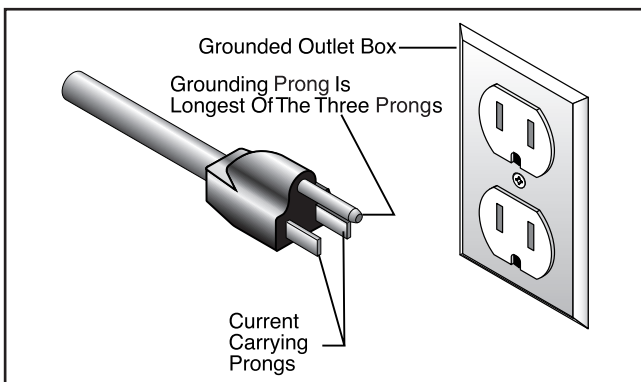

**Figure 1.** NEMA 5-15 plug and receptacle.

### Grounding

In the event of an electrical short, grounding reduces the risk of electric shock. This tool is equipped with a power cord that has a grounding wire, which must be properly connected to the grounding prong on the plug; likewise, the outlet must be properly installed and grounded. All electrical connections must be made in accordance with local codes and ordinances.

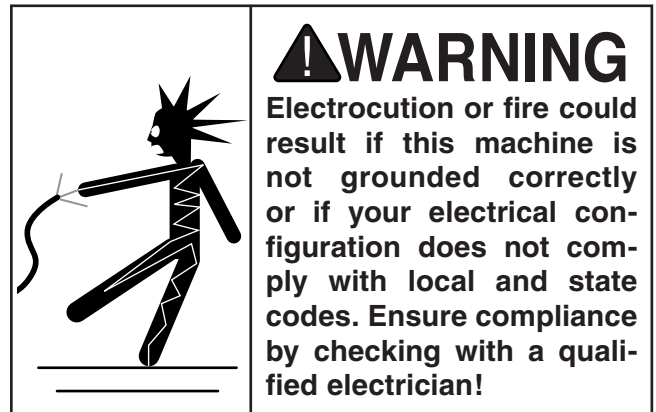

### Extension Cords

We do not recommend the use of extension cords. Instead, arrange the placement of your equipment and the installed wiring to eliminate the need for extension cords.

If you must use an extension cord at 110V with your machine:

- Use at least a 14 gauge cord that does not exceed 50 feet in length!
- The extension cord must also contain a ground wire and plug pin.
- Avoid cords over 50 feet long unless they have been sized by a qualified electrician.



# SECTION 3: SETUP

## Setup Safety

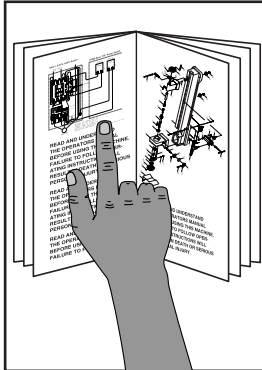

**!WARNING**  
 This machine presents serious injury hazards to untrained users. Read through this entire manual to become familiar with the controls and operations before starting the machine!



**!WARNING**  
 Wear safety glasses during the entire set up process!

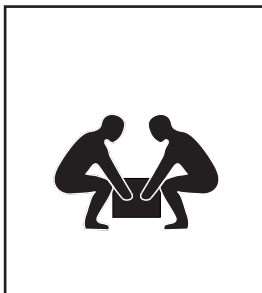

**!WARNING**  
 The jointer assembly is very heavy. DO NOT over-exert yourself while unpacking or moving your machine—get assistance.

## Items Needed for Setup

The following items are needed to complete the setup process, but are not included with your machine:

DESCRIPTION	Qty
• People for Lifting .....	2
• Straightedge (see <b>Page 28</b> ) .....	1
• Phillips Screwdriver #2 .....	1
• Wrench or Socket 17mm.....	2
• Wrench or Socket 14mm.....	1
• Wrench or Socket 13mm.....	1
• Wrench or Socket 12mm.....	1
• Degreaser.....	As Needed
• Rags for Cleaning .....	As Needed

## Unpacking

The Model G0604 was carefully packed when it left our warehouse. If you discover the machine is damaged after you have signed for delivery, *please immediately call Customer Service at (570) 546-9663 for advice.*

Save the containers and all packing materials for possible inspection by the carrier or its agent. *Otherwise, filing a freight claim can be difficult.*

When you are completely satisfied with the condition of your shipment, you should inventory the contents.



# Inventory

After all the parts have been removed from the two boxes, you should have the following items:

<b>Jointer Box: (Figure 2)</b>		<b>Qty</b>
A.	Jointer Assembly .....	1
B.	Carriage.....	1
C.	Fence .....	1
D.	Extension Table.....	1
E.	Push Blocks.....	2
F.	Cutterhead Guard.....	1
G.	Tool Hardware Bag	
	—Hex Wrenches 2.5, 4, 5, 6, 8mm... 1 Each	
	—Open-end Wrench 8/10mm .....	1
H.	Knife Setting Jig (not shown) .....	1

<b>Stand Box: (Figure 3)</b>		<b>Qty</b>
I.	Stand Assembly w/Motor .....	1
J.	Pedestal Switch.....	1
K.	Dust Port .....	1
L.	Wheel Assembly.....	1
M.	Belt Guard .....	1
N.	V-Belt.....	1

<b>Assembly Fasteners</b>		<b>Qty</b>
•	Hex Bolt M8-1.25 x 50 (Wheel/Stand) .....	1
•	Flat Washer 8mm (Wheel/Stand).....	1
•	Hex Bolts M10-1.5 x 55 (Wheel/Stand).....	2
•	Flat Washers 10mm (Wheel/Stand).....	2
•	Hex Nuts M10-1.5 (Wheel/Stand) .....	2
•	Cap Screws M8-1.25 x 25 (Jointer/Stand) .	4
•	Lock Washers 8mm (Jointer/Stand).....	4
•	Flange Bolts M6-1 x 12 (Belt Guard) .....	2
•	Hex Nuts 6mm (Belt Guard).....	2
•	Flat Washers 6mm (Belt Guard) .....	2
•	Cap Screws M8-1.25 x 30 (Fence) .....	2
•	Cap Screws M8-1.25 x 20 (Pedestal) .....	2
•	Lock Washers 8mm (Pedestal).....	2
•	Flat Washers 8mm (Pedestal).....	2
•	Phillips Screws M5-.8 x 16 (Dust Port) .....	4
•	Flat Washers 5mm (Dust Port) .....	4
•	Cap Screws M10-1.5 x 30 (Carriage) .....	2
•	Flat Washers 10mm (Carriage).....	2
•	Cap Screws M6-1 x 20 (Ext Table).....	2

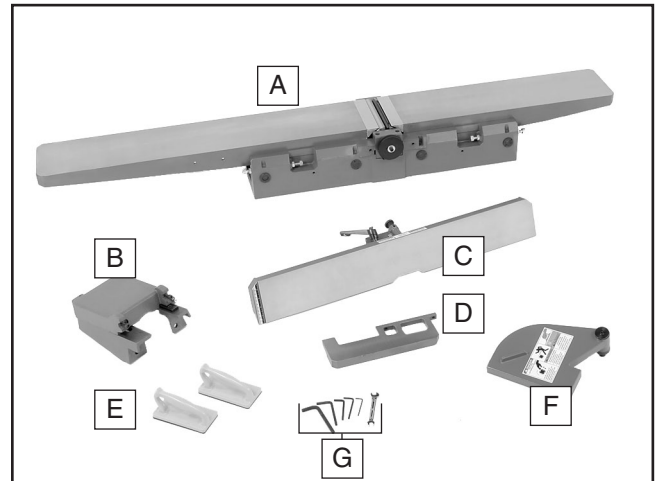

Figure 2. Box 1 inventory contents.

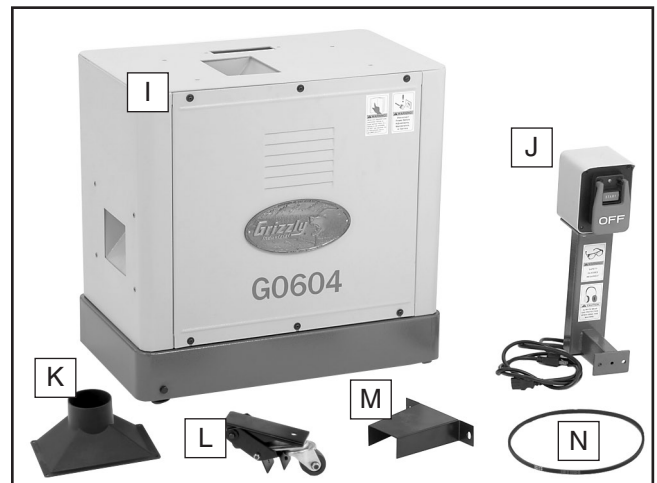

Figure 3. Box 2 inventory contents.

In the event that any nonproprietary parts are missing (e.g. a nut or a washer), we would be glad to replace them, or for the sake of expediency, replacements can be obtained at your local hardware store.

## NOTICE

Some assembly fasteners may arrive pre-installed on the machine. Check the mounting locations on the machine before assuming that any items from the inventory list are missing.



# Hardware Recognition Chart

USE THIS CHART TO MATCH UP  
HARDWARE DURING THE ASSEMBLY  
PROCESS!

MEASURE BOLT DIAMETER BY PLACING INSIDE CIRCLE

- #10
- 1/4"
- 5/16"
- 3/8"
- 7/16"
- 1/2"

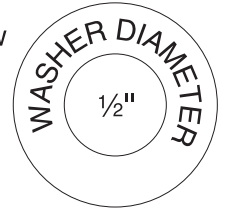
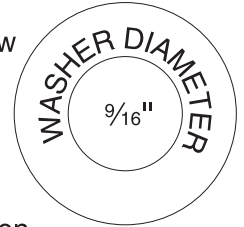
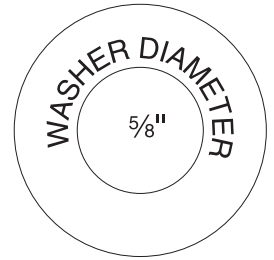
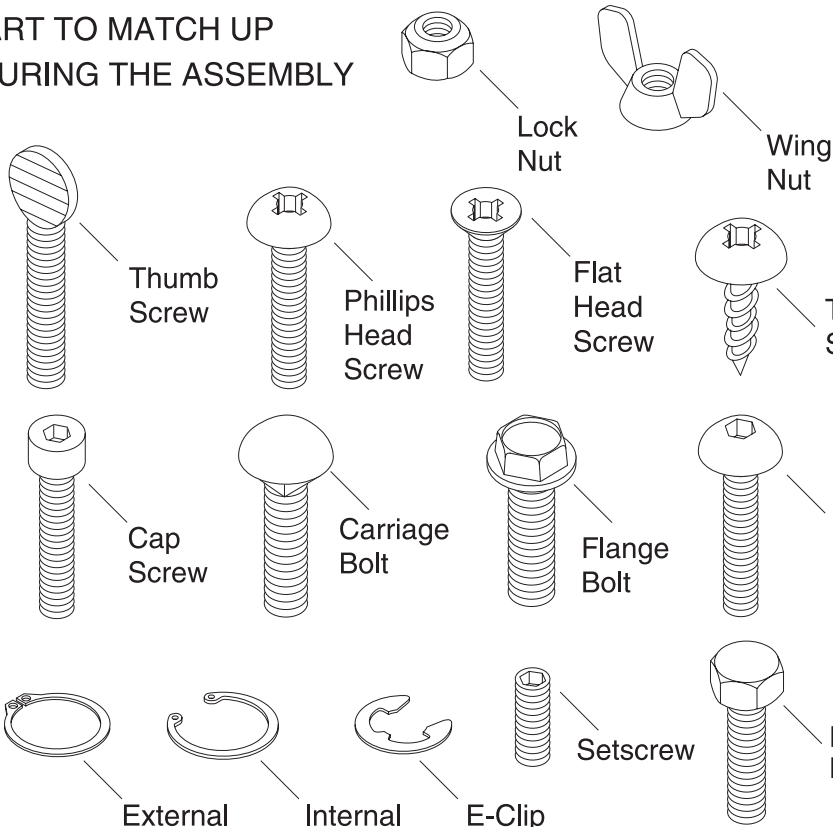

#10

- 4mm
- 6mm
- 8mm
- 10mm
- 12mm
- 16mm

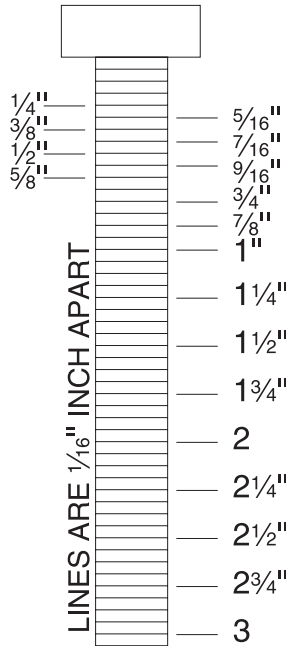
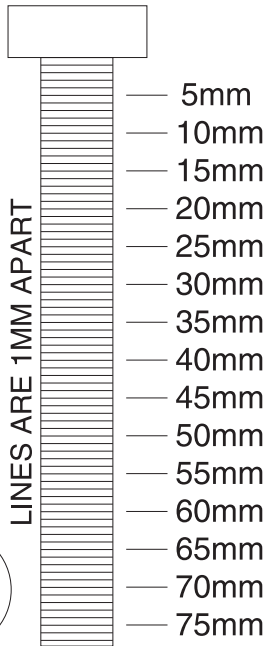

WASHERS ARE MEASURED BY THE INSIDE DIAMETER

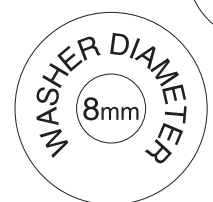
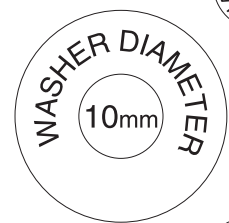
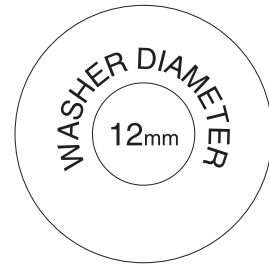

# Cleanup

The unpainted cast iron surfaces are coated with a waxy oil to protect them from corrosion during shipment. Remove this protective coating with a solvent cleaner or citrus-based degreaser such as Grizzly's G7895 Degreaser. To clean thoroughly, some parts may need to be removed. **For optimum performance from your machine, make sure you clean all moving parts or sliding contact surfaces that are coated.** Avoid chlorine-based solvents, such as acetone or brake parts cleaner, as they may damage painted surfaces should they come in contact.

# Site Considerations

## Machine Placement

Consider the jointer dimensions and size of material to be processed through each machine, and space for auxiliary stands, work tables or other machinery when establishing a location for your jointer. See **Figure 4** for the Model G0604 overhead view dimensions.

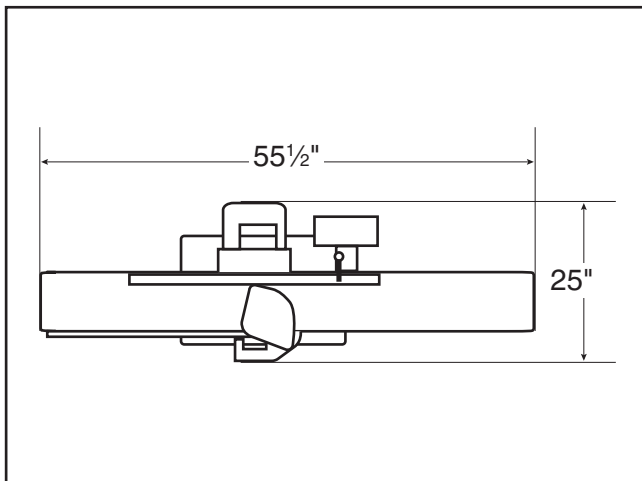

**Figure 4.** Model G0604 overhead view dimensions.

# Wheel Assembly

Components and Hardware Needed:	Qty
Wheel Assembly.....	1
Stand Assembly w/Motor.....	1
Hex Bolt M8-1.25 x 50.....	1
Flat Washer 8mm.....	1
Hex Bolts M10-1.5 x 55.....	2
Flat Washers 10mm.....	2
Hex Nuts M10-1.5.....	2

## To attach the wheel:

1. Carefully lay the stand on its side so you can access the underside.
2. Bolt the wheel assembly to the stand with the provided hardware as shown in **Figure 5**.

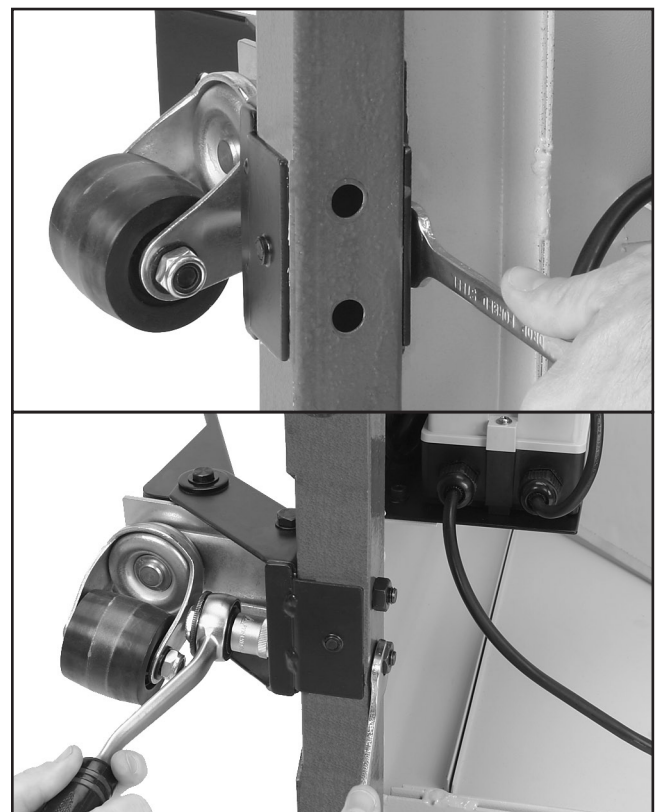

**Figure 5.** Bolting the wheel assembly to the stand.

3. Turn the stand rightside up.



# Jointer

Components and Hardware Needed:	Qty
Jointer Assembly .....	1
Stand Assembly w/Motor.....	1
Cap Screws M8-1.25 x 25.....	4
Lock Washers 8mm.....	4

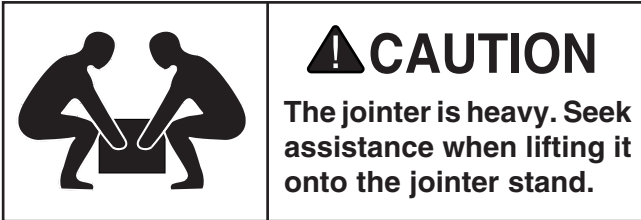

### To mount the jointer to the stand:

1. Remove the rear cover from the jointer stand.
2. With the help of an assistant, lift the jointer onto the stand.
3. Align the mounting holes on the jointer and stand.
4. Secure the jointer to the stand with the cap screws and washers as shown in **Figure 6**.



**Figure 6.** Securing jointer to stand.

# V-Belt

Components and Hardware Needed:	Qty
V-Belt.....	1
Belt Guard .....	1
Flange Bolts M6-1 x 12 .....	2
Hex Nuts 6mm.....	2
Flat Washers 6mm .....	2

### To install the V-belt:

1. Loosen the motor bracket fasteners shown in **Figure 7**.

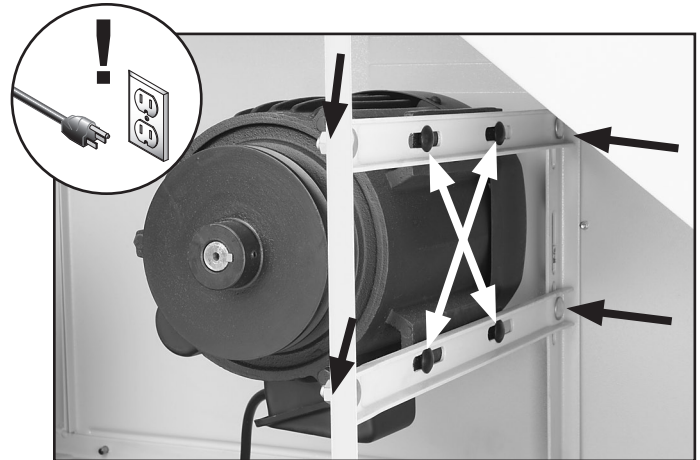
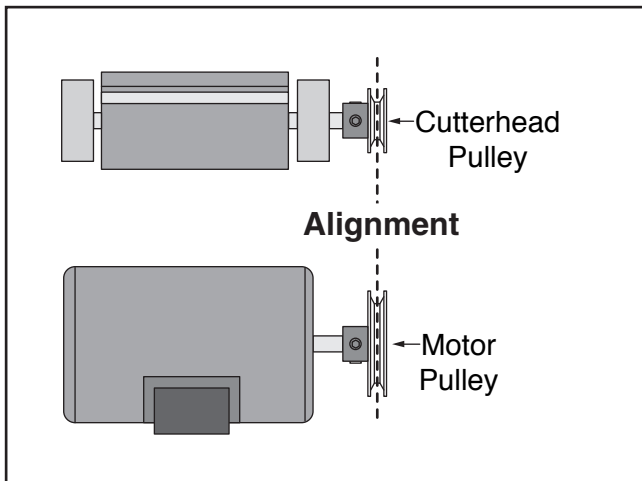

**Figure 7.** Motor bracket fasteners (black arrows); motor mount fasteners (white arrows).

2. Slide the motor upward and place the V-belt around the cutterhead pulley and the motor pulley.
3. Slide the motor down to tension the V-belt.
4. Visually check the alignment of the two pulleys to make sure that they are aligned and that the V-belt is straight up and down (see **Figure 8**).
  - If the pulleys are aligned, tighten the motor bracket fasteners and go to **Step 8**.
  - If the pulleys are NOT aligned, perform **Steps 5–7**.



# Checking Outfeed Table Height

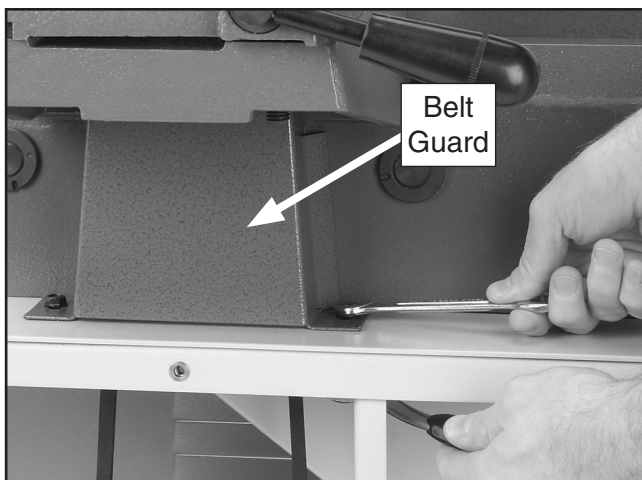

**Figure 8.** Pulleys aligned.

5. Remove the V-belt and loosen the motor mount fasteners.
6. Shift the motor horizontally as needed to align the motor pulley with the cutterhead pulley, then replace and retension the V-belt.
7. Tighten the motor mount fasteners.
8. Install the belt guard with the flange bolts, washers, and hex nuts (**Figure 9**).
9. Replace the access panel on the stand.

## **CAUTION**

The belt guard **MUST** be installed before operating the jointer or the moving V-belt will be exposed, creating an entanglement hazard at the back of the jointer.

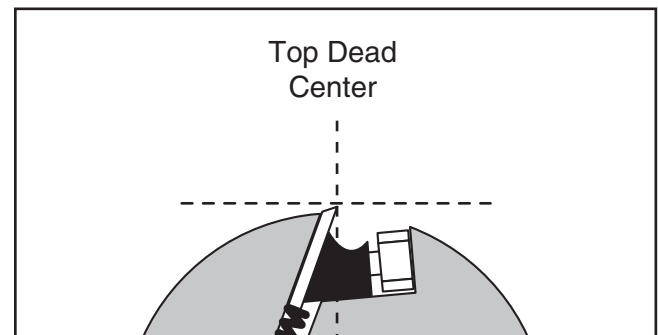

**Figure 9.** Installing belt guard.

The outfeed table **MUST** be level with the knives when they are at top dead center (their highest point during rotation) or the workpiece cannot be fed across the jointer safely.

### To check the outfeed table height:

1. Place a straightedge on the outfeed table so it extends over the cutterhead.
2. Rotate the cutterhead pulley until one of the knives is at top dead center, as illustrated in **Figure 10**.



**Figure 10.** Cutterhead knife at top dead center.



When correctly set, the knife will barely touch the straightedge, as shown in **Figure 11**.

—If your outfeed table is correctly set, no adjustments are necessary.

—If the knife lifts the straightedge off the table or it is below the straightedge, then the outfeed table must be reset. Refer to **Setting Outfeed Table Height** on **Page 38**.

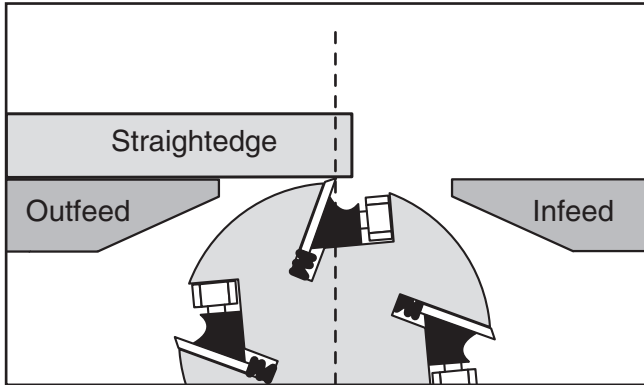

**Figure 11.** Using a straightedge to align outfeed table height with knife at TDC.

# Extension Table

Components and Hardware Needed:	Qty
Extension Table.....	1
Cap Screws M6-1 x 20.....	2

## To install the extension table:

1. Attach the extension table to the infeed table with the cap screws, as shown in **Figure 12**, but do not fully tighten the cap screws yet.

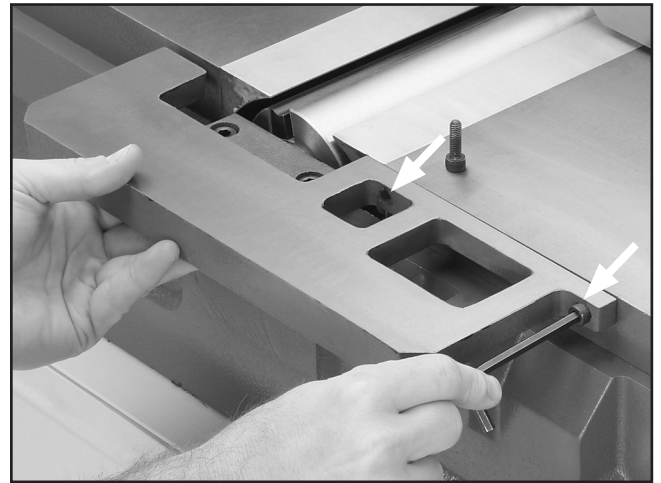

**Figure 12.** Installing extension table.

2. Use the straightedge to adjust the extension table flush with the infeed table.
3. Tighten the cap screws.



# Fence

Components and Hardware Needed:	Qty
Carriage.....	1
Fence.....	1
Cap Screws M10-1.5 x 30.....	2
Flat Washers 10mm.....	2
Cap Screws M8-1.25 x 30.....	2

## To install the fence:

1. Attach the fence carriage to the back of the table base (see **Figure 13**), but do not fully tighten the bolts yet.

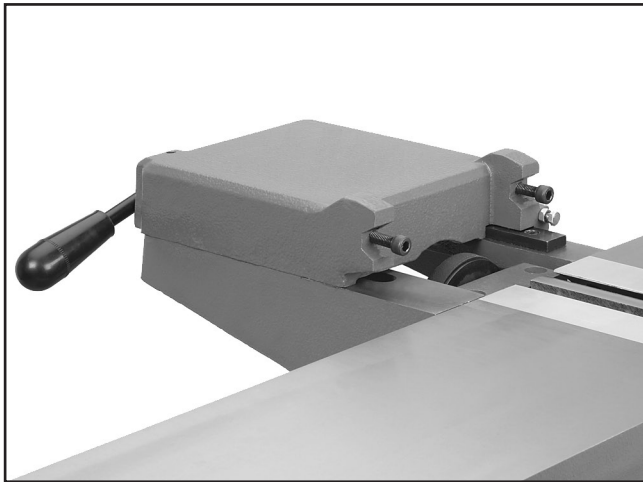

**Figure 13.** Fence carriage installed.

2. Place a piece of paper on the table and slide the carriage over the table top to allow it to rest on the paper and self align, as shown in **Figure 14**, then tighten the carriage mounting bolts.

**Note:** The paper will keep the carriage from making direct contact with the table, which will keep the fence from dragging across the table when it is installed.

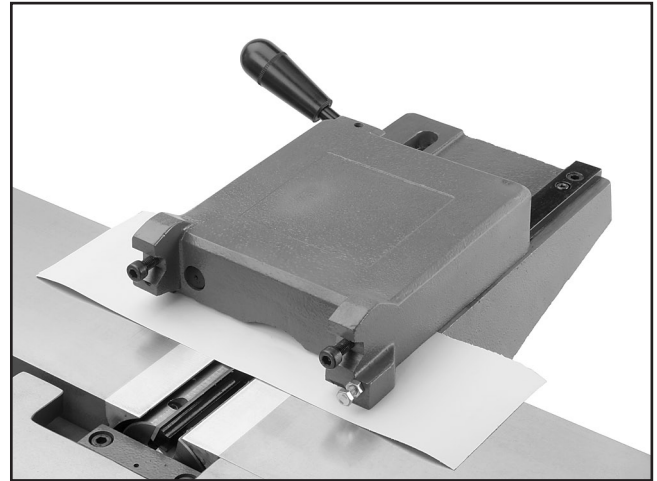

**Figure 14.** Carriage slide propped up on paper.

3. Attach the fence to the carriage, as shown in **Figure 15**.

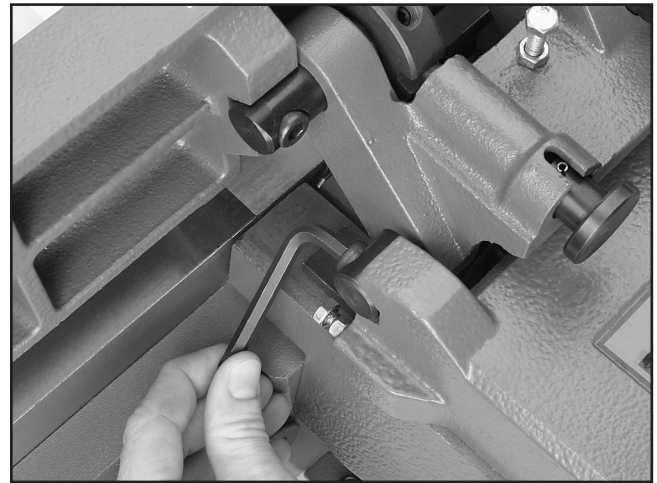

**Figure 15.** Attaching fence to carriage.

4. Install the tilt lever as shown in **Figure 16**.

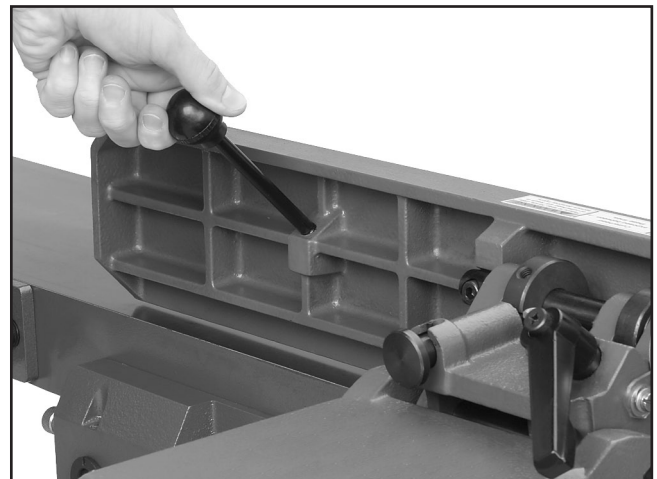

**Figure 16.** Installing the fence tilt lever.



# Cutterhead Guard

## **!WARNING**

The cutterhead guard is a critical safety feature on this machine—you **MUST** install and verify its operation before using the jointer! Failure to install this guard will greatly increase the chances of a serious injury.

Components and Hardware Needed:	Qty
Cutterhead Guard.....	1

### To install the cutterhead guard:

1. Move the fence all the way back, then raise it 2" off the table and lock it in place.
2. Insert cutterhead guard shaft so the flat is facing the set screw, then tighten the set screw against the shaft (see **Figure 17**), keeping the guard approximately 1/8" off the table.

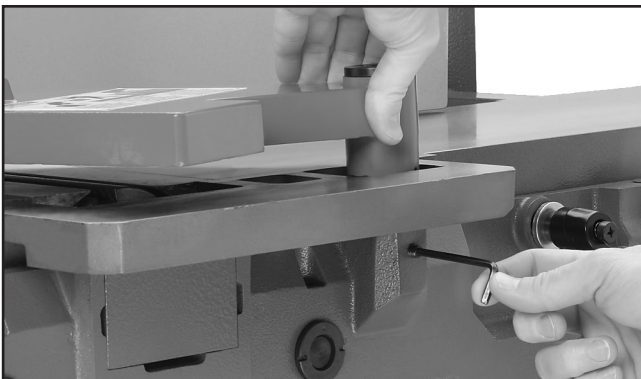

**Figure 17.** Installing the cutterhead guard.

3. Pull the cutterhead guard backward to tension the spring, then—while holding tension on the guard—move the fence into regular operating position and release the guard against the fence.
4. Test the guard. When pulled back and released, the guard should spring back over the cutterhead and stop against the fence.

—If the guard does not spring back over the cutterhead or drags across the table, reinstall it, making sure there is tension on the shaft when it is installed, so it will spring back over the fence.

# Pedestal Switch

Components and Hardware Needed:	Qty
Pedestal Switch.....	1
Cap Screws M8-1.25 x 20.....	2
Lock Washers 8mm.....	2
Flat Washers 8mm.....	2

### To install the pedestal switch:

1. Attach the pedestal switch with the cap screws, lock washers, and flat washers, as shown in **Figure 18**.

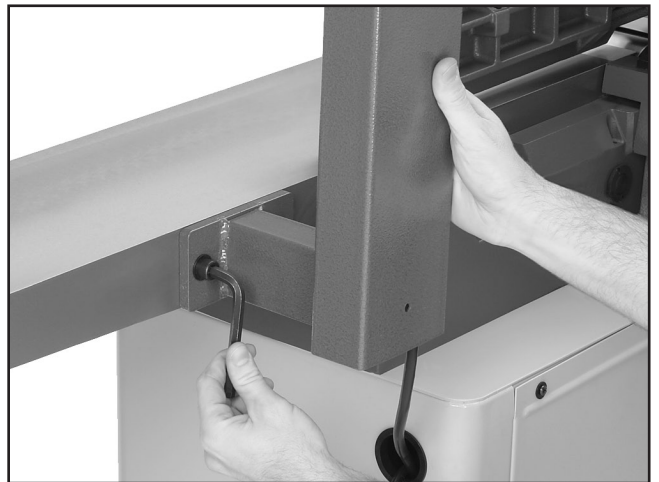

**Figure 18.** Attaching pedestal switch to stand.

2. Thread the excess motor cord through the access hole in the stand, and plug it into the switch cord.



# Knife Setting Jig

Components and Hardware Needed:	Qty
Knife Setting Jig Rod.....	1
Knife Setting Jig Foot.....	2
E-Clip.....	4

Assemble the knife setting jig as shown in **Figure 19**.

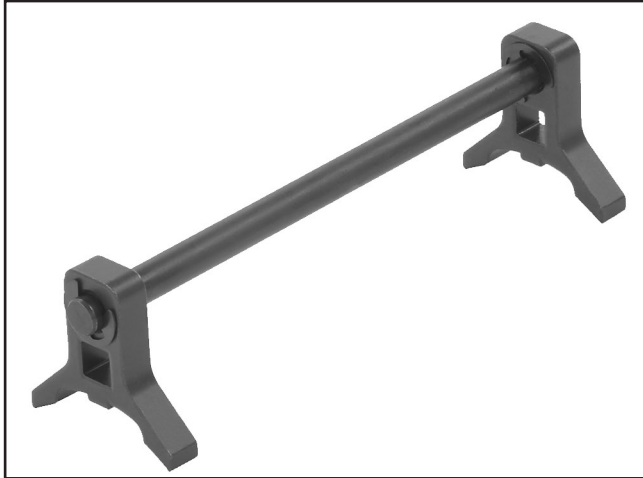
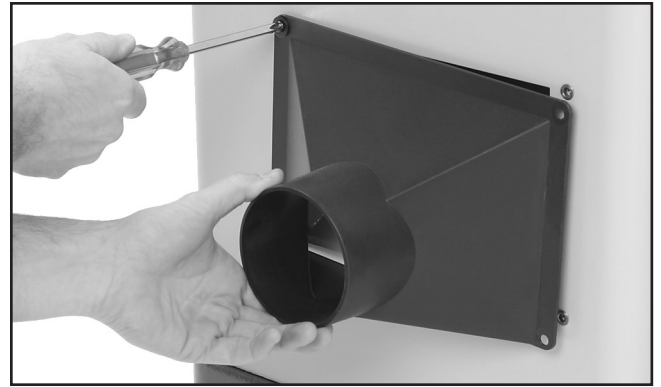

**Figure 19.** Knife setting jig assembly.

# Dust Port

Components and Hardware Needed:	Qty
Dust Port .....	1
Phillips Screws M5-.8 x 16.....	4
Flat Washers 5mm .....	4

Install the dust port as shown in **Figure 20**.



**Figure 20.** Installing dust port.

## CAUTION

**DO NOT** operate the Model G0604 without an adequate dust collection system. This machine creates substantial amounts of wood dust while operating. Failure to use a dust collection system can result in short and long-term respiratory illness.

**Recommended CFM at Dust Port: 400 CFM**  
*Do not confuse this CFM recommendation with the rating of the dust collector. To determine the CFM at the dust port, you must take into account many variables, including the CFM rating of the dust collector, the length of hose between the dust collector and the machine, the amount of branches or wyes, and the amount of other open lines throughout the system. Explaining this calculation is beyond the scope of this manual. If you are unsure of your system, consult an expert or purchase a good dust collection "how-to" book.*



# Test Run

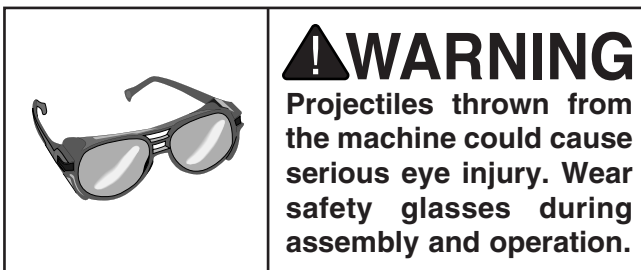
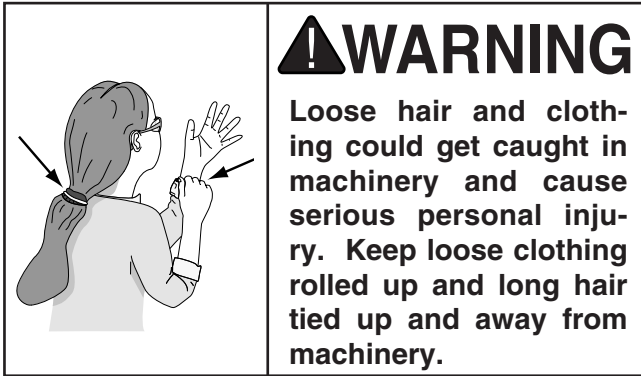

## Starting the machine:

1. Read the entire instruction manual first!
2. Make sure the cutterhead guard is installed and correctly adjusted (**Page 18**).
3. Make sure all tools and foreign objects have been removed from the machine.
4. Review **SECTION 2 (Page 9)** and connect your machine to the power source.
5. Turn the jointer **ON**.

—The jointer should run smoothly with little or no vibration.

—Immediately stop the jointer if you suspect any problems, and refer to **Page 31** to troubleshoot/fix any problems before starting the jointer again.

—If you need any help with your jointer call our Tech Support at (570) 546-9663.

# Recommended Adjustments

For your convenience, the adjustments listed below have been performed at the factory and no further setup is required to operate your machine.

However, because of the many variables involved with shipping, we recommend that you at least verify the following adjustments to ensure the best possible results from your new machine.

Step-by-step instructions for these adjustments can be found in **SECTION 7: SERVICE**.

## Factory adjustments that should be verified:

1. Knife Height Settings (**Page 33**).
2. Table Parallelism (**Page 36**).
3. Outfeed Table Height Even w/Knives at Top Dead Center (**Page 38**).
4. Depth Scale Calibration (**Page 40**).
5. Fence Stop Accuracy (**Page 40**).



# SECTION 4: OPERATIONS

## Operation Safety

### ⚠️ WARNING

Damage to your eyes, lungs, and ears could result from using this machine without proper protective gear. Always wear safety glasses, a respirator, and hearing protection when operating this machine.

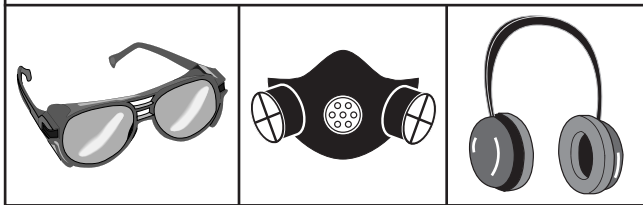

### ⚠️ WARNING

Loose hair and clothing could get caught in machinery and cause serious personal injury. Keep loose clothing and long hair away from moving machinery.

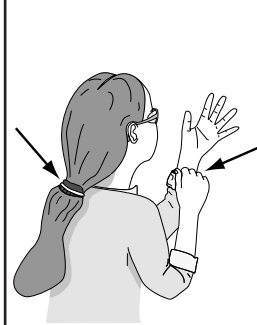

### ⚠️ WARNING

Lock the mobile base wheel before operating the jointer! Operating the jointer with the wheel unlocked may cause loss of control, resulting in serious personal injury.

### NOTICE

If you have never used this type of machine or equipment before, WE STRONGLY RECOMMEND that you read books, trade magazines, or get formal training before beginning any projects. Regardless of the content in this section, Grizzly Industrial will not be held liable for accidents caused by lack of training.

## Basic Controls

This section covers the basic controls used during routine operations.

### START & STOP Buttons (Figure 21)

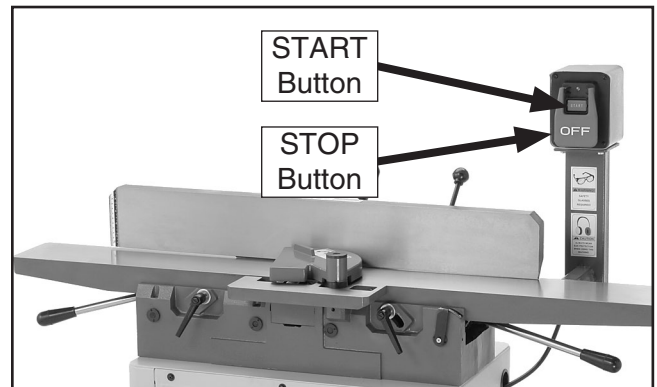

Figure 21. START/STOP button locations.

**Table Movement:** To move the infeed table, loosen the table lock (Figure 22), move the table with the table lever in the preset range, then tighten the table lock. The outfeed table is preset with no range of movement allowed, so if it gets accidentally unlocked it will not move. To adjust the preset range of movement, refer to **SECTION 7: SERVICE** about setting table heights.

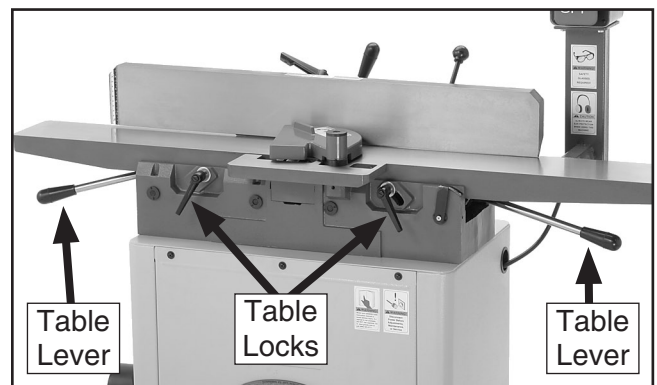
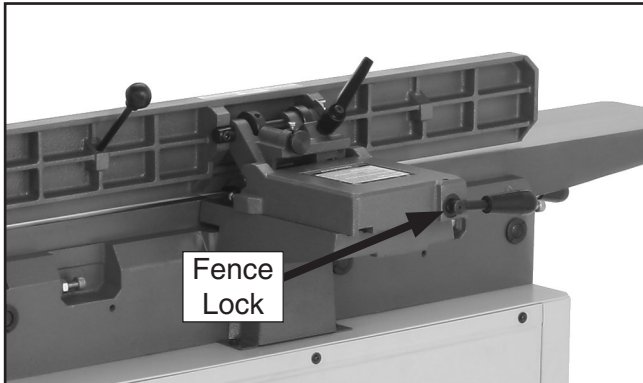

Figure 22. Table control locations.



**Fence Movement:** The fence has a lock that keeps it in position (**Figure 23**). To move the fence, loosen the lock and slide the fence where needed.



**Figure 23.** Fence lock location.

**Fence Tilting:** The tilt lock (**Figure 24**) secures the fence at any position in the available range. The plunger locks into an indexing ring to easily set the fence tilt to 90° after moving it. Two positive stops stop the fence at 45° inward and 45° outward (135°) for common 45° bevel cuts. Even when the fence is resting against the positive stops, the tilt lock must be tightened before cutting.

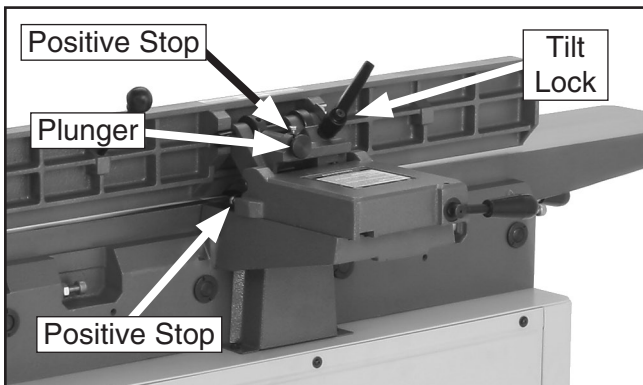

**Figure 24.** Tilt lock and plunger locations.

# Stock Inspection and Requirements

Here are some rules to follow when choosing and jointing stock:

- **Jointing and surface planing WITH the grain produces a better finish and is safer for the operator.** Cutting with the grain is described as feeding the stock on the jointer so the grain points down and toward you as viewed on the edge of the stock (**Figure 25**).

**Note:** If the grain changes direction along the edge of the board, decrease the cutting depth and make additional passes.

- **DO NOT joint or surface plane stock that contains large or loose knots.** Injury to the operator or damage to the workpiece can occur if the knots become dislodged during the cutting operation.
- **DO NOT joint or surface plane against the grain direction.** Cutting against the grain increases the likelihood of stock kickback, as well as tear-out on the workpiece.

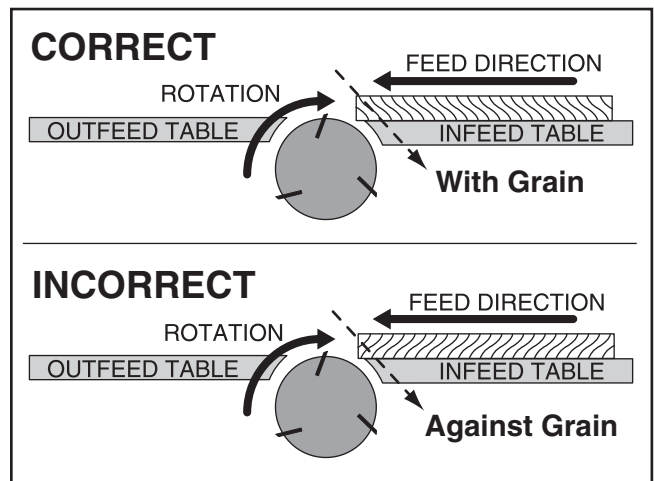

**Figure 25.** Correct and incorrect grain alignment with cutterhead.



- **Remove foreign objects from the stock.** Make sure that any stock you process with the jointer is clean and free of any dirt, nails, staples, tiny rocks or any other foreign objects that may damage the jointer blades.
- **Only process natural wood fiber through your jointer.** Never joint MDF, particle board, plywood, laminates or other synthetically made materials.
- **Make sure all stock is sufficiently dried before jointing.** Wood with a moisture content over 20% will cause unnecessary wear on the knives and poor cutting results.
- **Make sure your workpiece exceeds the minimum dimension requirements (Figures 26 & 27) before edge jointing or surface planing, or it may break or kick back during the operation!**

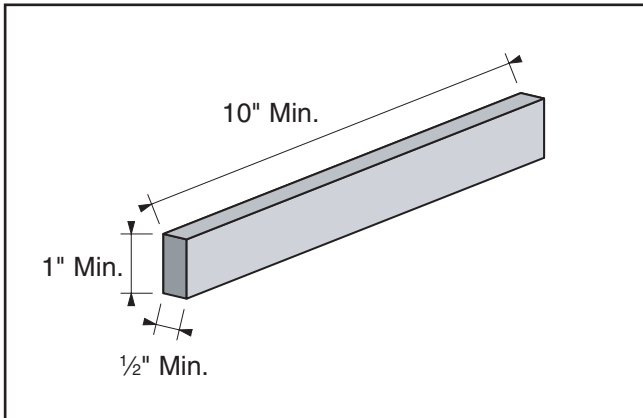

**Figure 26.** Minimum dimensions for edge jointing.

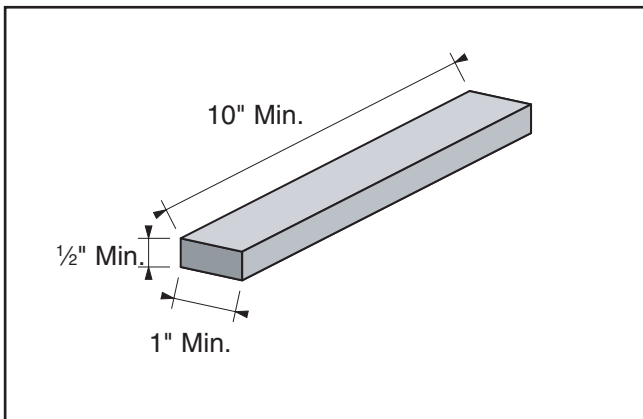
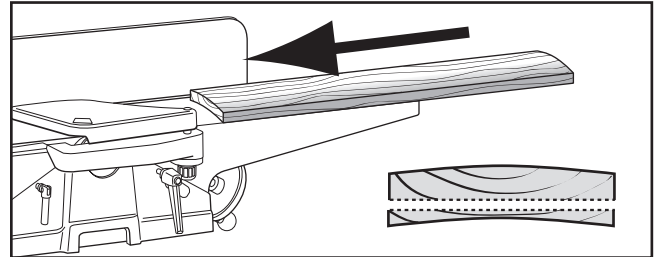

**Figure 27.** Minimum dimensions for surface planing.

# Squaring Stock

**Squaring stock involves four steps performed in the order below:**

**1. Surface Plane On The Jointer**—The concave face of the workpiece is surface planed flat with the jointer.



**2. Surface Plane On a Thickness Planer**—The opposite face of the workpiece is surface planed flat with a thickness planer.

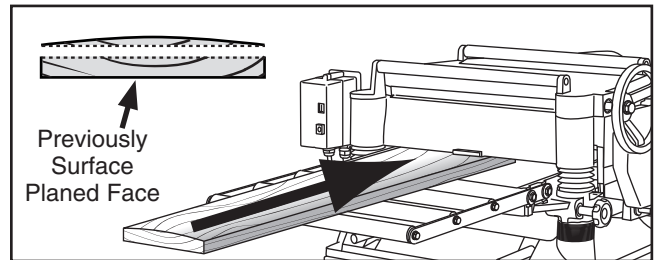

**3. Edge Joint On The Jointer**—The concave edge of the workpiece is jointed flat with the jointer.

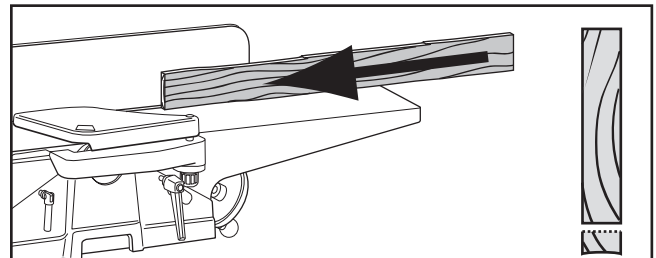

**4. Rip Cut On A Table Saw**—The jointed edge of the workpiece is placed against a table saw fence and the opposite edge cut off.

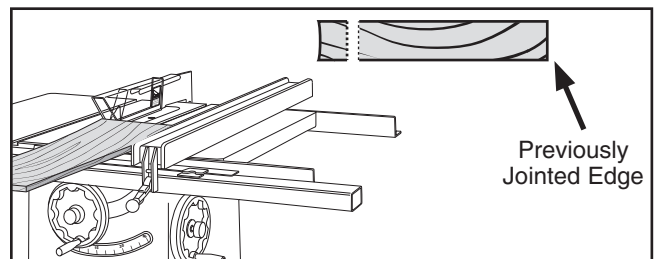

# Surface Planing

The purpose of surface planing on the jointer is to make one flat face on a piece of stock (see **Figures 28 & 29**) to prepare it for surface planing on a thickness planer.

## NOTICE

If you are not experienced with a jointer, set the depth of cut to zero, and practice feeding the workpiece across the tables as described. This procedure will better prepare you for the actual operation.

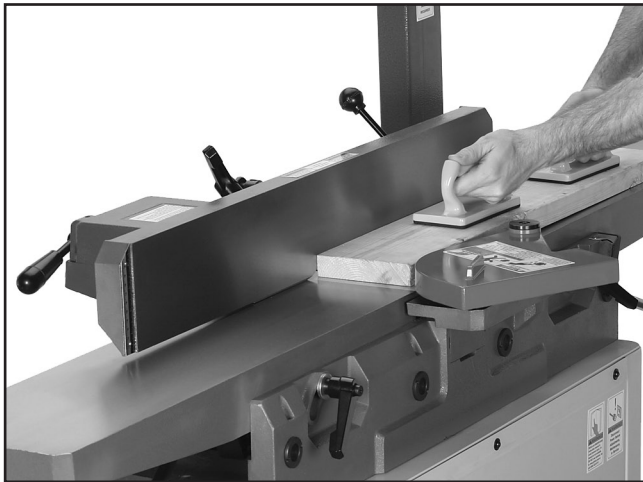

Figure 28. Typical surface planing operation.

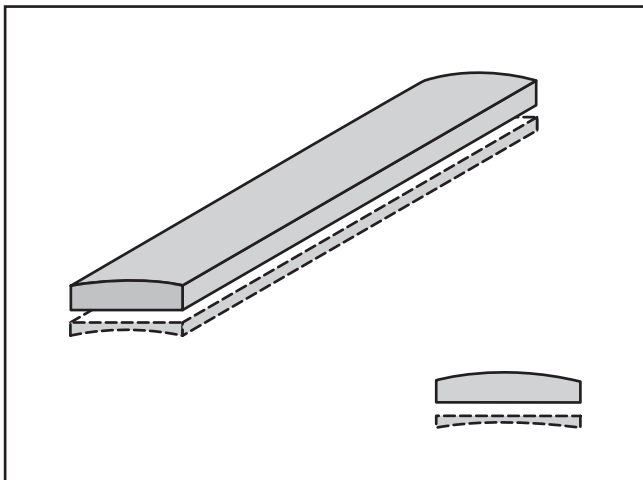

Figure 29. Illustration of surface planing results.

To surface plane on the jointer:

1. Read and understand **SECTION 1: SAFETY**, beginning on **Page 6**.
2. Make sure your stock has been inspected for dangerous conditions as described in the **Stock Inspection & Requirements** instructions, beginning on **Page 22**.
3. Set the cutting depth for your operation. (We suggest  $\frac{1}{32}$ " for surface planing.)
4. Make sure your fence is set to  $90^\circ$ .
5. If your workpiece is cupped (warped), place it so the concave side is face down on the surface of the infeed table.
6. Start the jointer.

## WARNING

Failure to use push blocks when surface planing may result in cutterhead contact, which will cause serious personal injury. Always use push blocks to protect your hands when surface planing on the jointer.

7. With a push block in each hand, press the workpiece against the table and fence with firm pressure, and feed the workpiece over the cutterhead.

**Note:** If your leading hand (with push block) gets within 4" of the cutterhead, lift it up and over the cutterhead, and place the push block on the portion of the workpiece that is on the outfeed table. Now, focus your pressure on the outfeed end of the workpiece while feeding, and repeat the same action with your trailing hand when it gets within 4" of the cutterhead. To keep your hands safe, **DO NOT** let them get closer than 4" from the cutterhead when it is moving!

8. Repeat **Step 7** until the entire surface is flat.



# Edge Jointing

The purpose of edge jointing is to produce a finished, flat-edged surface (see **Figures 30 & 31**) that is suitable for joinery or finishing. It is also a necessary step when squaring rough or warped stock.

## NOTICE

If you are not experienced with a jointer, set the depth of cut to zero, and practice feeding the workpiece across the tables as described below. This procedure will better prepare you for the actual operation.



**Figure 30.** Typical edge jointing operation.

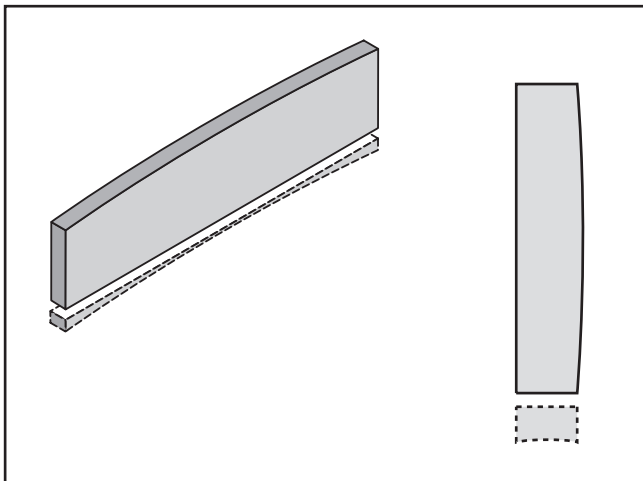

**Figure 31.** Illustration of edge jointing results.

To edge joint on the jointer:

1. Read and understand **SECTION 1: SAFETY**, beginning on **Page 6**.
2. Make sure your stock has been inspected for dangerous conditions as described in the **Stock Inspection** instructions, beginning on **Page 22**.
3. Set the cutting depth for your operation. (We suggest between  $\frac{1}{16}$ " and  $\frac{1}{8}$ " for edge jointing, using a more shallow depth for hard wood species or for wide stock.)
4. Make sure the fence is set to  $90^\circ$ .
5. If your workpiece is cupped (warped), place it so the concave side is face down on the surface of the infeed table.
6. Start the jointer.
7. Press the workpiece against the table and fence with firm pressure. Use your trailing hand to guide the workpiece through the cut, and feed the workpiece over the cutterhead.

**Note:** If your leading hand gets within 4" of the cutterhead, lift it up and over the cutterhead, and place it on the portion of the workpiece that is over the outfeed table. Now, focus your pressure on the outfeed end of the workpiece while feeding, and repeat the same action with your trailing hand when it gets within 4" of the cutterhead. To keep your hands safe, **DO NOT** let them get closer than 4" from the cutterhead when it is moving!

8. Repeat **Step 7** until the entire edge is flat.



# Bevel Cutting

The purpose of bevel cutting is to cut a specific angle into the edge of a workpiece (see **Figures 32 & 33**).

The Model G0604 has preset fence stops at 45° inward, 90°, and 45° outward (135°). If your situation requires a different angle, the fence can be locked anywhere between these angles.

## NOTICE

If you are not experienced with a jointer, set the depth of cut to zero, and practice feeding the workpiece across the tables as described below. This procedure will better prepare you for the actual operation.



**Figure 32.** Typical bevel cutting operation.

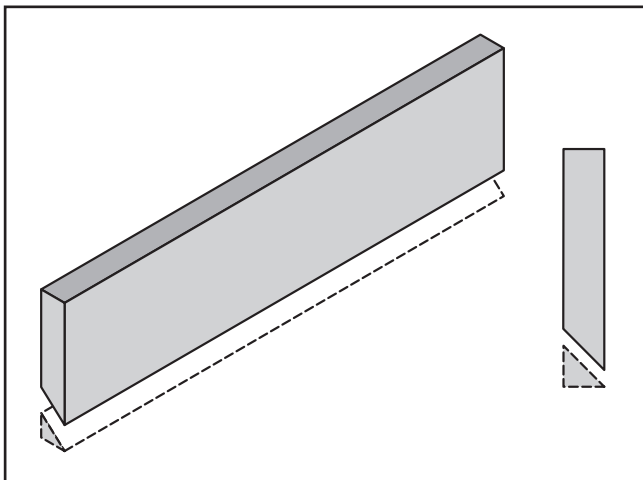

**Figure 33.** Illustration of bevel cutting results.

## To bevel cut on the jointer:

1. Read and understand **SECTION 1: SAFETY**, beginning on **Page 6**.
2. Make sure your stock has been inspected for dangerous conditions as described in the **Stock Inspection** instructions, beginning on **Page 22**.
3. Set the cutting depth for your operation. (We suggest between  $\frac{1}{16}$ " and  $\frac{1}{8}$ " for bevel cutting, using a more shallow depth for hard wood species or for wide stock.)
4. Make sure your fence is set to the angle of your desired cut.
5. If your workpiece is cupped (warped), place it so the concave side is face down on the surface of the infeed table.
6. Start the jointer.
7. With a push block in your leading hand, press the workpiece against the table and fence with firm pressure, and feed the workpiece over the cutterhead.

**Note:** If your leading hand gets within 4" of the cutterhead, lift it up and over the cutterhead, and place the push block on the portion of the workpiece that is on the outfeed table. Now, focus your pressure on the outfeed end of the workpiece while feeding, and repeat the same action with your trailing hand when it gets within 4" of the cutterhead. To keep your hands safe, **DO NOT** let them get closer than 4" from the cutterhead when it is moving!

8. Repeat **Step 7** until the angled cut is satisfactory to your needs.



# SECTION 5: ACCESSORIES

## G3640—Power Twist® V-Belt - ½" x 48"

Smooth running with less vibration and noise than solid belts. The Power Twist® V-belt can be customized in minutes to any size—just add or remove sections to fit your needs. Size: ½" x 48"; replaces all "A" sized V-belts. Requires one Power Twist® V-belt to replace the stock V-belt on the Model G0604.

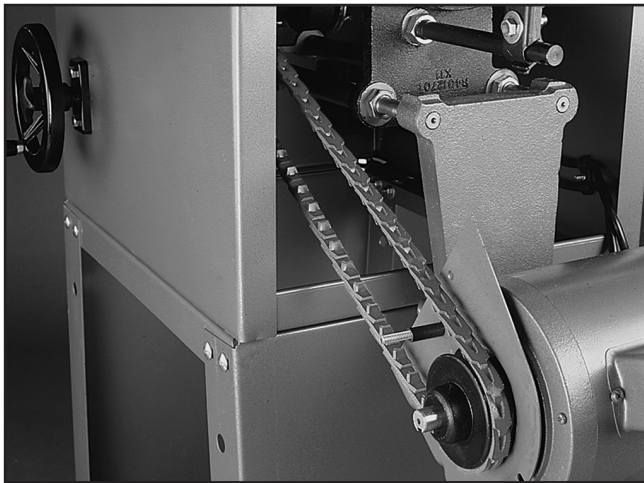

Figure 34. G3640 Power Twist® V-Belt.

## H9218—6" Byrd® Shelix Cutterhead

Made in the USA by Byrd, this indexable carbide insert cutterhead is the best money can buy—period! The inserts are not only placed in a spiral pattern, they are also positioned at an angle so the shearing action leaves a glassy smooth cut on the toughest and most figured woods. Comes with 5 extra replacement inserts. Very nice upgrade!

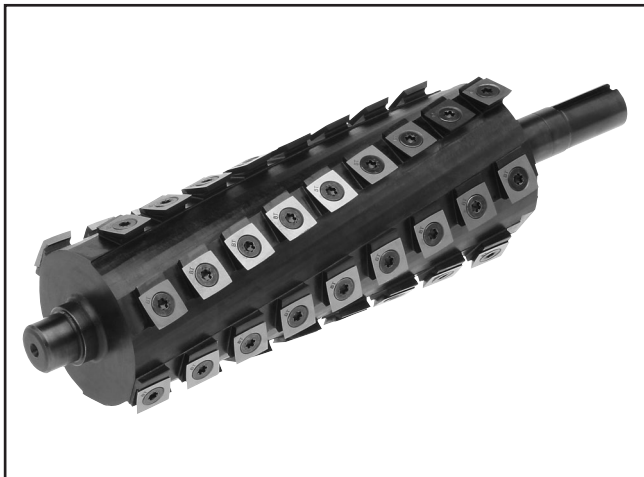

Figure 35. H9218 Byrd Shelix Cutterhead.

## G1753—Jointer Pal® Magnetic Knife Jig (For HSS & Cobalt Knives)

## G1756—Jointer Pal® Magnetic Knife Jig (For Carbide Knives)

This patented magnetic knife-setting system lets you set jointer knives in perfect alignment every time! It also allows you to shift nicked knives to get a perfect cut to an accuracy of + or - 0.001".



Figure 36. G1753 Jointer Pal® Knife Jig.

## G3631—Jointer/Planer Knife Hone

Add a razor hone to your planer and jointer knives with this hand-held sharpening device. This handy tool sharpens flat and beveled surfaces quickly and easily. Great for touch-ups.



Figure 37. G3631 Jointer/Planer Knife Hone.

Call 1-800-523-4777 To Order



- G5562—SLIPIT® 1 Qt. Gel
- G5563—SLIPIT® 12 oz Spray
- G2871—Boeshield® T-9 12 oz Spray
- G2870—Boeshield® T-9 4 oz Spray
- H3788—G96® Gun Treatment 12 oz Spray
- H3789—G96® Gun Treatment 4.5 oz Spray



**Figure 38.** Recommended products for protecting unpainted cast iron/steel parts on machinery.

- H9219—Dispoz-A-Blade® System (Includes 4 Holders & Knife Inserts)
- H9220—Dispoz-A-Blade® Knife Inserts (Set of 4)

Install a Dispoz-A-Blade® Knife system in your new jointer and save up to 70% on knife replacements for the life of your jointer. Each knife insert is double-edged, so you get two knives in one, and is indexed so that all knife inserts can be installed at the same height in just minutes. Very simple and super fast knife changes!

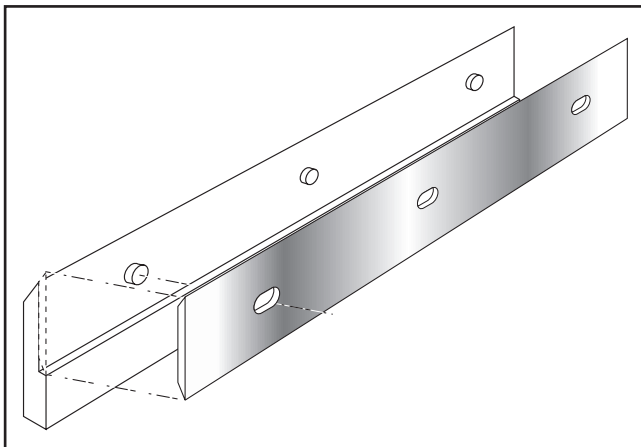

**Figure 39.** Dispoz-A-Blade® Holder and Knife.

- H9221—6" HSS Replacement Jointer Knives (Set of 4)

- H1411—PowerHands™ Safety Stick

This safety push stick features interchangeable traction treads; one for flat stock, and one for pressing against table and fence. It also has a spring loaded push-pin for full workpiece contact. Made in the USA.



**Figure 40.** H1411 PowerHands™ Safety Stick.

- G9643—8" Precision Straightedge
- G9644—12" Precision Straightedge
- H2675—16" Precision Straightedge

These grade 00 heavy-duty stainless steel straightedges are manufactured to DIN874 standards for professional results in set-up and inspection work.



**Figure 41.** Straightedges.

**Call 1-800-523-4777 To Order**



- G7984—Face Shield**
- H1298—Dust Sealed Safety Glasses**
- H1300—UV Blocking, Clear Safety Glasses**
- H2347—Uvex® Spitfire Safety Glasses**
- H0736—Shop Fox® Safety Glasses**

Safety Glasses are essential to every shop. If you already have a pair, buy extras for visitors or employees. You can't be too careful when it comes to shop safety!



**Figure 42.** Our most popular safety glasses.

- H6175—Power Respirator**
- H6892—3M Pre-Filter, 10-Pack**
- H6893—Filter Cartridge, 10-Pack, P100**

Say goodbye to foggy safety glasses and labored breathing, this battery powered respirator supplies a constant breeze of fresh air all day long. Comes with its own plastic case for clean, sealed storage. Finally, a respirator you can look forward to wearing—at an affordable price!



**Figure 43.** H6175 Power Respirator.

- H2499—Small Half-Mask Respirator**
- H3631—Medium Half-Mask Respirator**
- H3632—Large Half-Mask Respirator**
- H3635—Disposable Cartridge Filter Pair P100**

Wood dust is a known carcinogen and has been linked to nasal cancer and severe respiratory illnesses. If you work around dust everyday, a half-mask respirator can be a lifesaver. Also compatible with safety glasses!



**Figure 44.** Half-mask respirator and disposable cartridge filters.

- G9256—6" Dial Caliper**
- G9257—8" Dial Caliper**
- G9258—12" Dial Caliper**

Required for jointing, planing, or sanding to critical tolerances. These traditional dial calipers are accurate to 0.001" and can measure outside surfaces, inside surfaces, and heights/depths. Features stainless steel, shock resistant construction and a dust proof display. An absolute treat for the perfectionist!

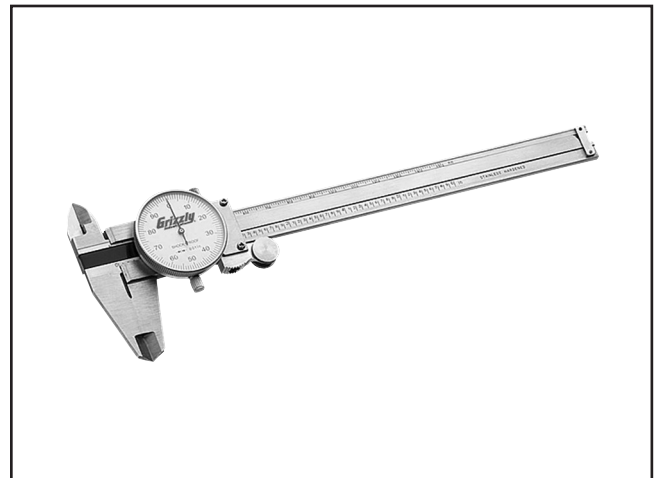

**Figure 45.** Grizzly® Dial Calipers.

**Call 1-800-523-4777 To Order**



# SECTION 6: MAINTENANCE

---

---



## Schedule

---

---

For optimum performance from your machine, follow this maintenance schedule and refer to any specific instructions given in this section.

### Daily

- Vacuum all dust on and around the machine.
- Wipe down tables and all other unpainted cast iron with a metal protectant.

### Monthly Check

- V-belt tension, damage, or wear.
- Clean/vacuum dust buildup from inside cabinet and off of motor.

## V-Belt

---

---

To ensure optimum power transmission from the motor to the blade, the V-belt must be in good condition (free from cracks, fraying and wear) and properly aligned and tensioned (refer to the instructions on **Page 14**).

## Cleaning

---

---

Cleaning the Model G0604 is relatively easy. Vacuum excess wood chips and sawdust, and wipe off the remaining dust with a dry cloth. If any resin has built up, use a resin dissolving cleaner to remove it.

Protect the unpainted cast iron surfaces on the table by wiping the table clean after every use—this ensures moisture from wood dust does not remain on bare metal surfaces.

Keep tables rust-free with regular applications of products like G96® Gun Treatment, SLIPIT®, or Boeshield® T-9 (see **Page 28**).

## Lubrication

---

---

Since all bearings are sealed and permanently lubricated, simply leave them alone until they need to be replaced. **DO NOT** lubricate them.



# SECTION 7: SERVICE

Review the troubleshooting and procedures in this section to fix your machine if a problem develops. If you need replacement parts or you are unsure of your repair skills, then feel free to call our Technical Support at (570) 546-9663.

## Troubleshooting Guide

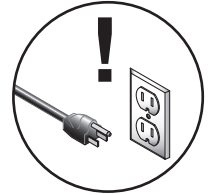

### Motor & Machine Operation

Symptom	Possible Cause	Possible Solution
Motor will not start.	<ol style="list-style-type: none"> <li>1. Thermal overload protection tripped in magnetic switch.</li> <li>2. Low voltage.</li> <li>3. Open circuit in motor or loose connections.</li> </ol>	<ol style="list-style-type: none"> <li>1. Press the "Reset" button on the thermal overload relay, located inside the magnetic switch.</li> <li>2. Check power line for proper voltage.</li> <li>3. Inspect all lead connections on motor for loose or open connections.</li> </ol>
Fuses or circuit breakers blow.	<ol style="list-style-type: none"> <li>1. Short circuit in line cord or plug.</li> </ol>	<ol style="list-style-type: none"> <li>1. Repair or replace cord or plug for damaged insulation and shorted wires.</li> </ol>
Motor overheats.	<ol style="list-style-type: none"> <li>1. Motor overloaded during operation.</li> <li>2. Air circulation through the motor restricted.</li> </ol>	<ol style="list-style-type: none"> <li>1. Reduce load on motor; take lighter cuts.</li> <li>2. Clean out motor to provide normal air circulation.</li> </ol>
Motor stalls or shuts off during a cut.	<ol style="list-style-type: none"> <li>1. Motor overloaded during operation.</li> <li>2. Thermal overload protection tripped in magnetic switch.</li> <li>3. Short circuit in motor or loose connections.</li> <li>4. Circuit breaker tripped.</li> </ol>	<ol style="list-style-type: none"> <li>1. Reduce load on motor; take lighter cuts.</li> <li>2. Press the "Reset" button on the thermal overload relay, located inside the magnetic switch.</li> <li>3. Repair or replace connections on motor for loose or shorted terminals or worn insulation.</li> <li>4. Install correct circuit breaker; reduce number of machines running on that circuit (circuit overload).</li> </ol>
Blade slows when cutting or makes a squealing noise, especially on start-up.	<ol style="list-style-type: none"> <li>1. V-belt loose.</li> <li>2. V-belt worn out.</li> </ol>	<ol style="list-style-type: none"> <li>1. Tighten V-belt (<b>Page 14</b>).</li> <li>2. Replace V-belt (<b>Page 14</b>).</li> </ol>
Loud repetitious noise coming from machine.	<ol style="list-style-type: none"> <li>1. Pulley setscrews or keys are missing or loose.</li> <li>2. Motor fan is hitting the cover.</li> <li>3. V-belt is damaged.</li> </ol>	<ol style="list-style-type: none"> <li>1. Inspect keys and setscrews. Replace or tighten if necessary.</li> <li>2. Adjust fan cover mounting position, tighten fan, or shim fan cover.</li> <li>3. Replace V-belt (<b>Page 14</b>).</li> </ol>
Vibration when running or cutting.	<ol style="list-style-type: none"> <li>1. Loose or damaged blade.</li> <li>2. Damaged V-belt.</li> <li>3. Worn cutterhead bearings.</li> </ol>	<ol style="list-style-type: none"> <li>1. Tighten or replace blade.</li> <li>2. Replace.</li> <li>3. Check/replace cutterhead bearings.</li> </ol>



## Table

Symptom	Possible Cause	Possible Solution
Tables are hard to adjust.	1. Table lock is engaged or partially engaged. 2. Table stops blocking movement.	1. Completely loosen the table lock. 2. Loosen/reset table positive stops.

## Cutting

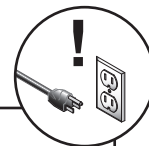

Symptom	Possible Cause	Possible Solution
Excessive snipe (gouge in the end of the board that is uneven with the rest of the cut).	1. Outfeed table is set too low. 2. Operator pushing down on trailing end of the workpiece.	1. Align outfeed table with cutterhead knife at top dead center ( <b>Page 15</b> ). 2. Reduce/eliminate downward pressure on that end of workpiece.
Workpiece stops in the middle of the cut.	1. Outfeed table is set too high.	1. Align outfeed table with cutterhead knife at top dead center ( <b>Page 15</b> ).
Chipping.	1. Knots or conflicting grain direction in wood. 2. Nicked or chipped blades. 3. Feeding workpiece too fast. 4. Taking too deep of a cut.	1. Inspect workpiece for knots and grain ( <b>Page 22</b> ); only use clean stock. 2. Adjust one of the nicked knives sideways; replace knives ( <b>Page 33</b> ). 3. Slow down the feed rate. 4. Take a smaller depth of cut. (Always reduce cutting depth when surface planing or working with hard woods.)
Fuzzy Grain.	1. Wood may have high moisture content or surface wetness. 2. Dull knives.	1. Check moisture content and allow to dry if moisture is too high. 2. Replace knives ( <b>Page 33</b> ).
Long lines or ridges that run along the length of the board.	1. Nicked or chipped knives.	1. Adjust one of the nicked knives sideways; replace knives ( <b>Page 33</b> ).
Uneven cutter marks, wavy surface, or chatter marks across the face of the board.	1. Feeding workpiece too fast. 2. Knives not adjusted at even heights in the cutterhead.	1. Slow down the feed rate. 2. Adjust the knives so they are set up evenly in the cutterhead ( <b>Page 33</b> ).
Board edge is concave or convex after jointing.	1. Board not held with even pressure on infeed and outfeed table during cut. 2. Board started out extremely warped. 3. Board has excessive bow or twist along its length. 4. Insufficient number of passes.	1. Hold board with even pressure as it moves over the cutterhead. 2. Take partial cuts to remove the extreme high spots before doing a full pass. 3. Surface plane one face so there is a good surface to position against the fence. 4. It may take 3 to 5 passes to achieve a perfect edge, depending on the starting condition of the board and the depth of cut.
Cuts aren't square.	1. Fence is not perpendicular to the tables.	1. Recalibrate the 90° fence stop ( <b>Page 40</b> ).
Overall cut quality is poor; inconsistent snipe problems; or consistent difficulty feeding workpiece.	1. Infeed and outfeed tables are not parallel with each other.	1. Recalibrate the jointer in this order: a. Set the infeed and outfeed tables parallel with each other ( <b>Page 36</b> ). b. Set the knives ( <b>Page 33</b> ). c. Set the outfeed table height to the knives ( <b>Page 38</b> ). d. Calibrate the fence stops ( <b>Page 40</b> ).



# Inspecting Knives

The height of the knives can be inspected with a straightedge to ensure that they are set evenly with the outfeed table at their highest point in the cutterhead rotation.

## To inspect the knives:

1. DISCONNECT JOINTER FROM POWER SOURCE!
2. Remove the cutterhead guard or block it out of the way.
3. Using a straightedge on the outfeed table, check the height of each knife at the positions shown in **Figure 46**.

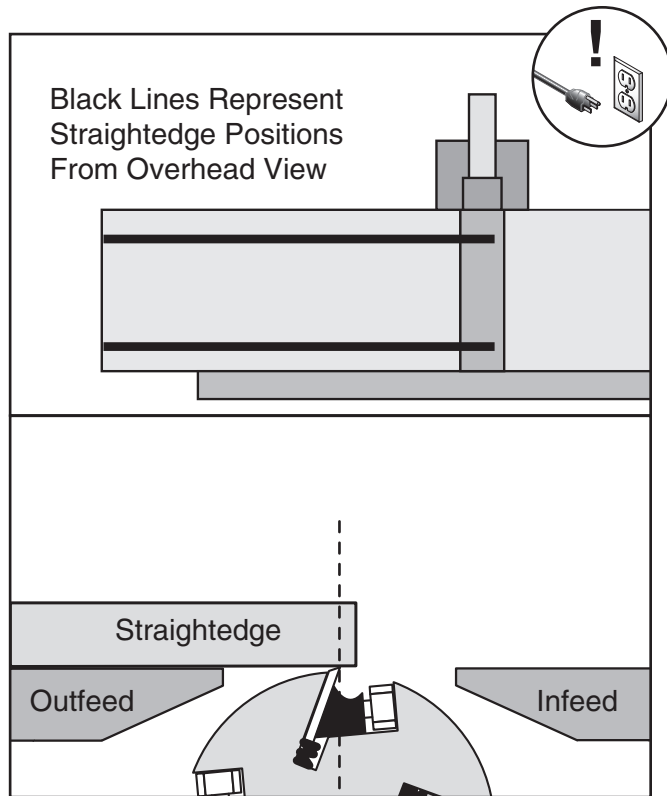

**Figure 46.** Checking knife height with a straightedge.

—The knives are set correctly when they just touch the bottom of the straightedge in each of the straightedge positions.

—If the knives do not touch the straightedge or they lift it up in any of the positions, then those knives need to be adjusted.

# Adjusting/Replacing Knives

Setting the knives correctly is crucial to the proper operation of the jointer and is very important in keeping the knives sharp. If one knife is higher than the others, it will do the majority of the work, and thus, dull much faster than the others.

There are two options for setting the knives—the straightedge method and the knife setting jig method. Each option has advantages and disadvantages and the correct one for you will become a matter of personal preference. For best results, the tables must be parallel with each other (**Checking/Adjusting Table Parallelism** on **Page 36**) and the outfeed table height must be properly set (**Setting Outfeed Table Height** on **Page 38**) before adjusting/replacing the knives.

**Straightedge Method:** A high quality straightedge is held flat against the outfeed table and the knife heights are set to the bottom of the straightedge, as shown in **Figure 46**. Because the knife projection height from the cutterhead is dependent on the outfeed table height, the outfeed table must be set as described in **Setting Outfeed Table Height** on **Page 38** for this method to work correctly.

When using a straightedge to set the knives, you will not need to move the outfeed table once it is set and you will always be assured that the knives are even with the outfeed table in their highest point of rotation—even if the cutterhead is not parallel with the outfeed table.



**Knife Setting Jig Method:** Both tables are lowered to fit the jig on the cutterhead, as shown in **Figure 47**, and the knife heights are set to just touch the middle pad of the jig.

The knife setting jig makes it easy to ensure that the knives project out of the cutterhead evenly. After using the knife setting jig to set the knives, you have to re-adjust the outfeed table height to ensure that it is even with the knives at their highest point of rotation. If you use the positive stops on the tables, reset them before operation.

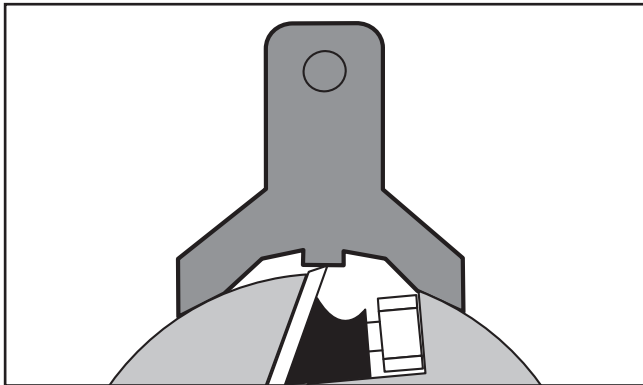

**Figure 47.** Using knife setting jig to set knife height.

The Model G0604 comes with both jack screws and springs inside the cutterhead to provide two options for adjusting the knives (see **Figure 48**).

**Note:** Only one of these options is needed to set the knives—see **Step 5** for clarification.

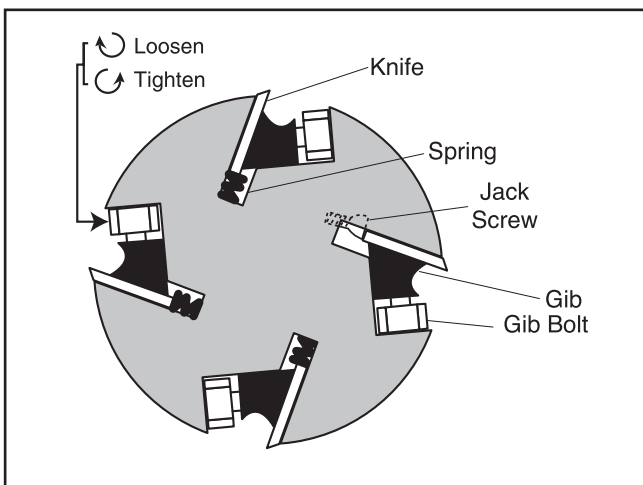

**Figure 48.** Cutterhead profile diagram.

Tools Needed	Qty
Straightedge .....	1
Knife Setting Jig (Optional) .....	1
Hex Wrench 4mm.....	1
Wrench 10mm.....	1

**To adjust/replace the knives:**

1. DISCONNECT JOINTER FROM POWER SOURCE!
2. Remove the cutterhead guard from the table and move the fence back as far as it will go.
3. Remove the belt guard to expose the cutterhead pulley.
4. Rotate the cutterhead pulley to get access to one of the cutterhead knives.
5. Loosen the cutterhead gib bolts, starting in the middle, and alternating back and forth until all of the gib bolts are loose, but not falling out.

—If this is the first time you are setting the knives, remove the gib and knife from the cutterhead. Decide which adjustment option you are going to use between the jack screws and the springs.

—If you decide to use the jack screws, remove the springs from the cutterhead (they are located directly below the knives).

—If you decide to use the springs, just thread the jack screws completely into the cutterhead so they will not get lost. Replace the gib and knife.



6. Remove and clean the gibs and clean inside the cutterhead slot to remove all pitch or sawdust. Coat the knives and gibs with a metal protectant (**Page 28**), then fit the gibs back in the cutterhead with the new knives.
7. Adjusting the knife heights:

**Jack Screws:** Using a 3mm hex wrench, find the jack screws through the access holes in the cutterhead (**Figure 49**) and rotate the jack screws to raise or lower the knife. When the knife is set correctly, it will barely touch the bottom of the straightedge or the knife setting jig middle pad. Snug the gib bolts tight enough to just hold the knife in place. Repeat on the other side of the cutterhead, then repeat **Steps 5–7** with the rest of the knives.

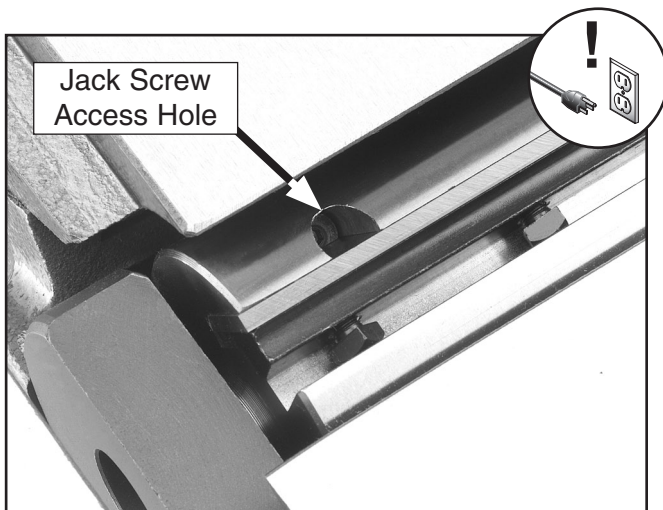

**Figure 49.** Jack screw access hole.

**Springs:** Push the knife down with the straightedge or middle pad of the knife setting jig, keeping the straightedge flat against the outfeed table or the knife setting jig feet evenly against the cutterhead. Tighten the gib bolts just tight enough to hold the knife in place. Repeat on the other side of the cutterhead, then repeat **Steps 5–7** with the rest of the knives.

8. Rotate the cutterhead to the first knife you started with. Slightly tighten all the gib bolts, starting in the middle and working your way to the ends by alternating left and right (**Figure 50**). Repeat this step on the rest of the knives.

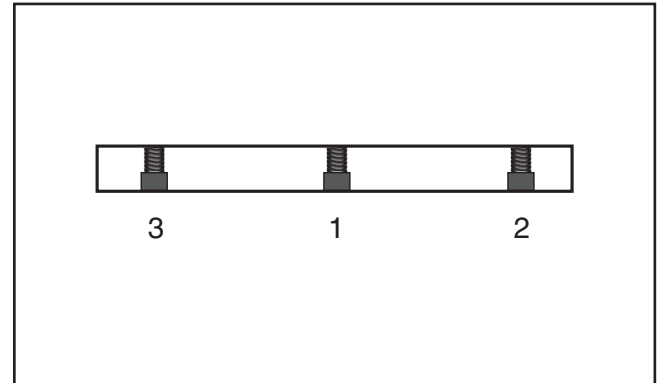

**Figure 50.** Gib bolt tightening sequence.

9. Repeat **Step 8**.
10. Repeat **Step 8**, but final tighten each gib bolt.
11. If you used the straightedge to set the knife heights, skip to the next step.

If you used the knife setting jig to set the knife heights, use the straightedge to adjust the outfeed table height evenly with the knives at top dead center (the highest point in their rotation).

12. Replace the cutterhead guard and the belt guard.



# Checking/Adjusting Table Parallelism

If the tables are not parallel with the cutterhead or each other, then poor cutting results and kickback can occur.

Tools Needed	Qty
Straightedge .....	1
Wrench 17mm .....	1
Hex Wrench 8mm.....	1
Hex Wrench 4mm.....	1
Hex Wrench 3mm.....	1

## Checking Outfeed Table

To check the outfeed table parallelism:

1. DISCONNECT JOINTER FROM POWER SOURCE!
2. Remove the cutterhead guard and fence.
3. Loosen the outfeed table lock located at the front of the machine, and loosen the jam nuts and positive stop bolts located at the back of the machine (see **Figure 51**).

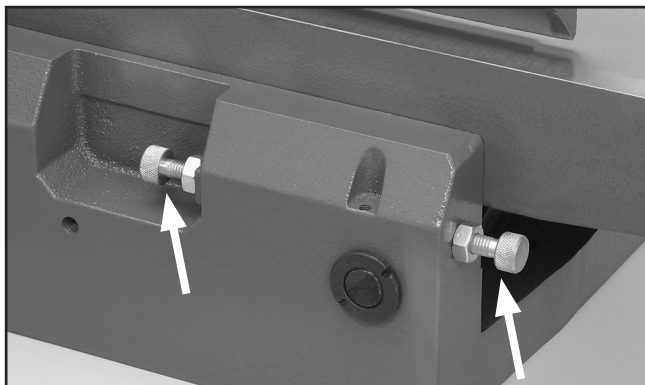

**Figure 51.** Outfeed table positive stop bolts.

4. Place the straightedge on the outfeed table so it hangs over the cutterhead, and lower the outfeed table until the straightedge just touches the body of the cutterhead, as shown in **Figure 52** (rotate the cutterhead if necessary).

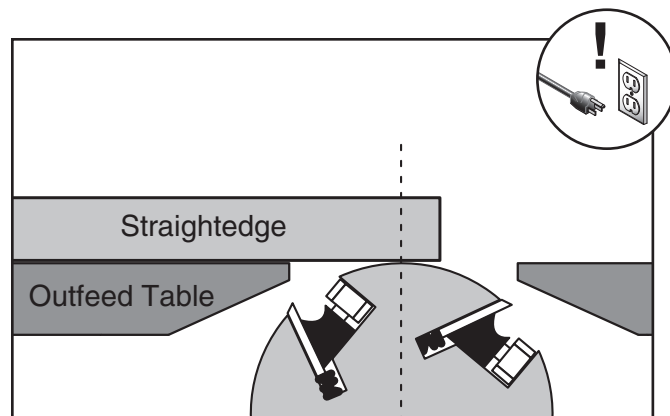

**Figure 52.** Adjusting outfeed table even with cutterhead body.

5. Place the straightedge in the positions shown in **Figure 53**. In each position, the straightedge should touch the cutterhead and sit flat on the outfeed table.

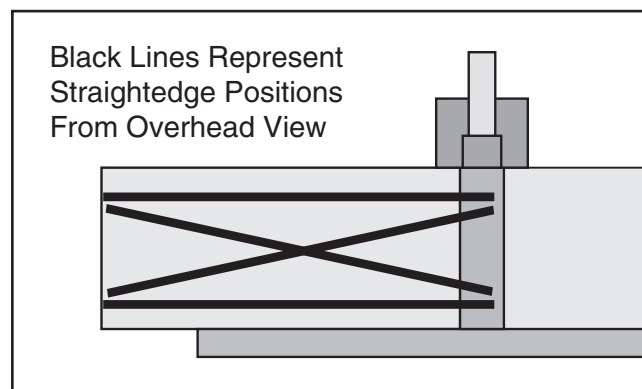

**Figure 53.** Straightedge positions for verifying if outfeed table is parallel with cutterhead.

—If the straightedge touches the cutterhead and sits flat across the outfeed table in each position, then the outfeed table is already parallel with the cutterhead. Check the infeed table to make sure that it is parallel with the outfeed table.

—If the straightedge does not touch the cutterhead and sit flat on the outfeed table in any of the positions, then the outfeed table is not parallel with the cutterhead. Correct the outfeed table parallelism, then correct the infeed table parallelism.



## Checking Infeed Table

To check the infeed table parallelism:

1. Follow all the steps for checking the outfeed table parallelism to first make sure that the outfeed table is parallel with the cutterhead.
2. Raise the outfeed table higher than the cutterhead.
3. Place the straightedge halfway across the infeed table and halfway over the outfeed table, and adjust the infeed table even with the outfeed table, as shown in **Figure 54**.

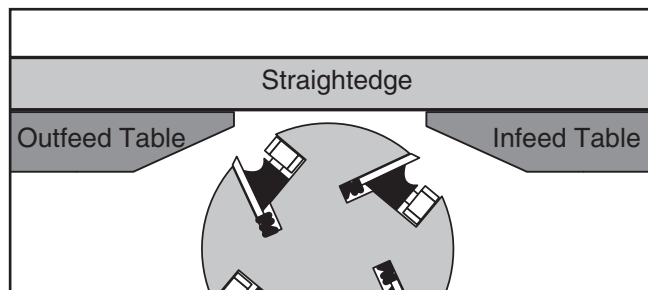

**Figure 54.** Infeed and outfeed tables set evenly.

4. Place the straightedge in the positions shown in **Figure 55**. In each position, the straightedge should sit flat against both the outfeed table and the infeed table.

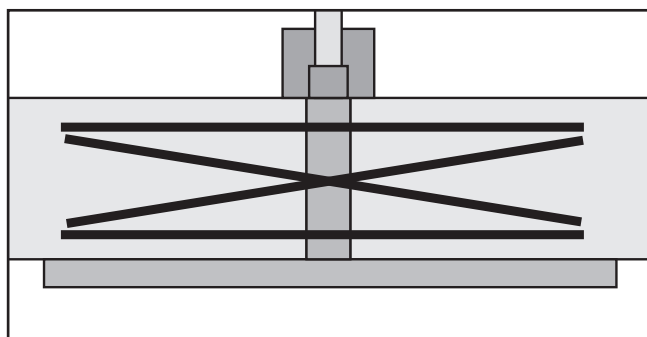

**Figure 55.** Straightedge positions for checking infeed/outfeed table parallelism.

—If the straightedge sits flat against both the infeed and outfeed table, then the tables are parallel. Set both table heights (**Pages 38 & 39**) and replace the cutterhead guard.

—If the straightedge does not sit flat against both the infeed and outfeed table in any of the positions, then follow the **Adjusting Table Parallelism** instructions.

## Adjusting Table Parallelism

For safe and proper cutting results, the tables must be parallel to the cutterhead. Adjusting them to be parallel is a task of precision and patience, and may take up to one hour to complete. Luckily, this is considered a permanent adjustment and should not need to be repeated for the life of the machine.

Due to the complex nature of this task, we recommend that you double check the current table positions to make sure that they really need to be adjusted before starting. Refer to the previous two subsections if you have not just completed them.

The tables have four eccentric bushings under each corner that allow the tables to be adjusted parallel. These eccentric bushings are locked in place by piggybacked set screws (one on top of the other) and adjust when unlocked and rotated.

The correct order for adjusting the table parallelism is to first adjust the outfeed table parallel with the cutterhead, then adjust the infeed table parallel with the outfeed table.

When setting the outfeed table, all measurements must be made from the cutterhead body—not the knives—or results may get skewed the next time you change knives.

**IMPORTANT:** The steps below are intended to be performed in succession with the procedures for checking the outfeed and infeed tables, beginning on **Page 36**. **DO NOT CONTINUE UNTIL YOU HAVE FOLLOWED THOSE PROCEDURES FIRST!**

To adjust the table parallelism:

1. Place the straightedge on the outfeed table so it hangs over the cutterhead, and lower the outfeed table until the straightedge just touches the cutterhead body, as shown in **Figure 52** (rotate the cutterhead if necessary).
2. Remove the set screw from each of the four eccentric bushings (**Figure 56**) under the outfeed table, and loosen the set screws underneath those removed set screws.



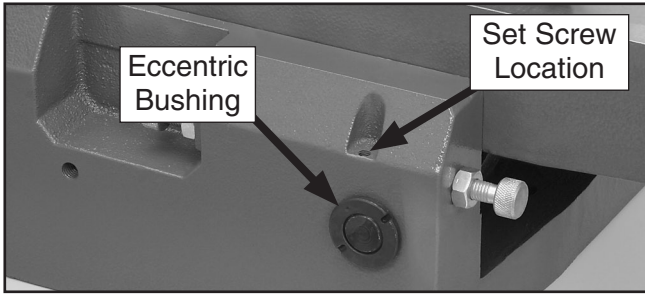

**Figure 56.** Eccentric bushing and set screw location.

3. Place the straightedge in one of the positions shown in **Figure 53**, and adjust the table by turning the eccentric bearings (a small hammer and punch or pin-type spanner wrench may be necessary), so that the straightedge touches the cutterhead while lying flat across the outfeed table. Repeat this step with each of the remaining straightedge positions as necessary until the outfeed table is parallel with the cutterhead.
4. Tighten/replace the set screws in the eccentric bushings on the outfeed table.
5. Remove the set screw from each of the four eccentric bushings under the infeed table, and loosen the set screws underneath those removed set screws.
6. Place the straightedge halfway across the infeed table and halfway over the outfeed table, and adjust the infeed table even with the outfeed table, as shown in **Figure 54**.
7. Place the straightedge in one of the positions shown in **Figure 55**, and adjust the eccentric bushings under the infeed table so the straightedge lies flat against both tables. Repeat this step with each of the remaining straightedge positions as many times as necessary until the infeed table is parallel with the outfeed table.
8. Tighten/replace the set screws in the eccentric bushings on the infeed table.
9. Set the knives (refer to **Page 33**), set the outfeed table height (refer to the next subsection), and recalibrate the fence stops (**Page 40**).
10. Reinstall the cutterhead guard.

# Setting Outfeed Table Height

The outfeed table height must be even with the top of the cutterhead knives. If the outfeed table is set too low, there will be snipe. If the outfeed table is set too high, the workpiece will hit the edge of the outfeed table during operation, increasing the chance of kickback.

<b>Tools Needed</b>	<b>Qty</b>
Straightedge .....	1
Wrench 17mm .....	1
Hex Wrench 8mm.....	1
Hex Wrench 4mm.....	1
Hex Wrench 3mm.....	1
Feeler Gauge(s) 0.062" .....	1

## To set the outfeed table height:

1. DISCONNECT JOINTER FROM POWER SOURCE!
2. Check/adjust the table parallelism.
3. Remove the cutterhead guard and fence.
4. Loosen the outfeed table lock located at the front of the machine, and loosen the jam nuts and positive stop bolts located at the back of the machine (see **Figure 51**).



5. Place the straightedge on the outfeed table so it hangs over the cutterhead, and lower the outfeed table until the straightedge is 0.062" ( $\frac{1}{16}$ " ) above the cutterhead body, as determined by using the feeler gauge or combination of feeler gauges (see **Figure 57**).

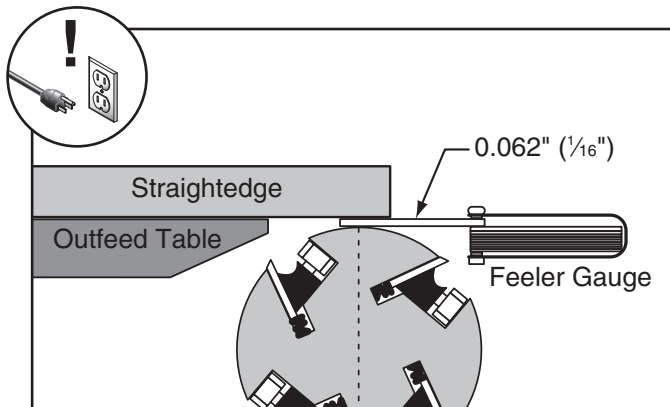

**Figure 57.** Using feeler gauge to set outfeed table height.

6. Tighten the outfeed table lock located at the front of the machine, and tighten the positive stop bolts and jam nuts located at the back of the machine (see **Figure 51**).
7. Set the knife heights to the new outfeed table height.

## Setting Infeed Table

The infeed table on the Model G0604 has positive stop bolts that, when properly set up, allow the operator to quickly adjust the infeed table between finish/final cuts and shaping/heavy cuts.

We recommend setting the minimum depth of cut to  $\frac{1}{32}$ " and the maximum depth of cut to  $\frac{1}{8}$ " for most operations. **DO NOT exceed  $\frac{1}{8}$ " cut per pass on this machine or kickback and serious injury may occur!**

Each positive stop bolt (**Figure 58**) controls the top or bottom range of the table movement. The jam nuts lock the positive stop bolt in position so it won't move during operation.

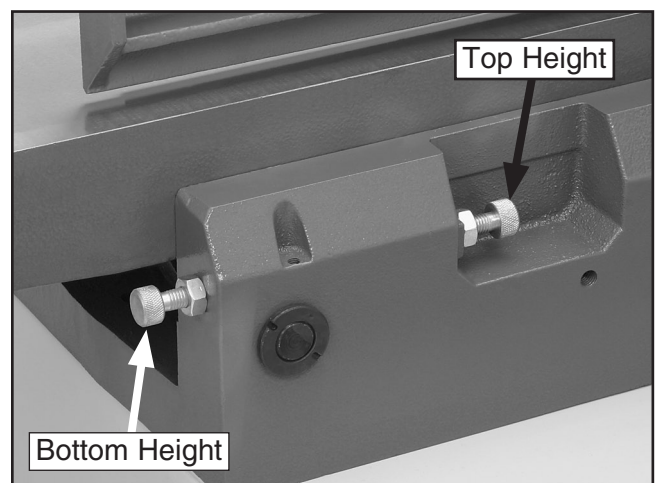

**Figure 58.** Positive stop bolts for infeed table.



# Calibrating Depth Scale

The depth scale on the infeed table can be calibrated or "zeroed" if it is not correct.

Tools Needed	Qty
Straightedge .....	1
Phillips Screwdriver .....	1

## To calibrate the depth scale:

1. DISCONNECT JOINTER FROM POWER SOURCE!
2. Loosen the infeed table positive stop bolts.
3. Use the straightedge to help adjust the infeed table exactly even with the outfeed table, as shown in **Figure 59**.

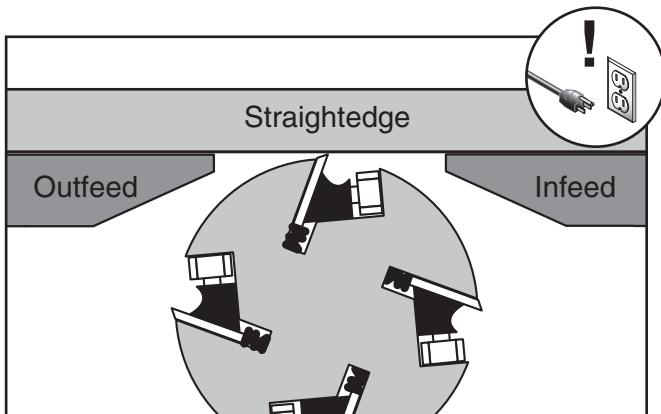

**Figure 59.** Infeed table even with outfeed table.

4. Using a screwdriver, adjust the scale pointer to zero (**Figure 60**), then reset the infeed table positive stops.

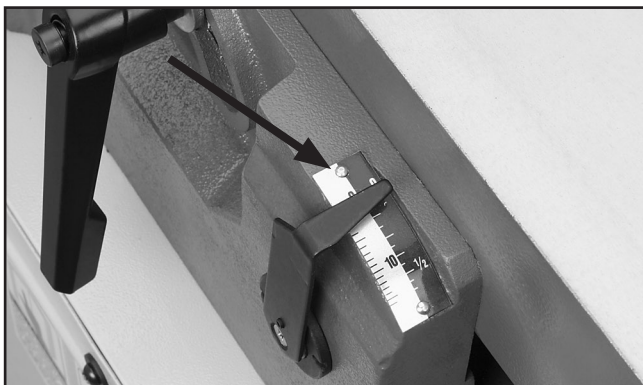

**Figure 60.** Depth scale adjusted to "0" position.

# Setting Fence Stops

The fence stops simplify the task of adjusting the fence to 45° inward, 90°, and 45° outward (135°).

Tools Needed	Qty
45° Square .....	1
90° Square .....	1
Sliding Bevel.....	1
Wrench 10mm .....	1
Hex Wrench 4mm.....	1

## To set the 45° inward fence stop:

1. Tilt the fence approximately 45° inward (**Figure 61**) onto the positive stop bolt.

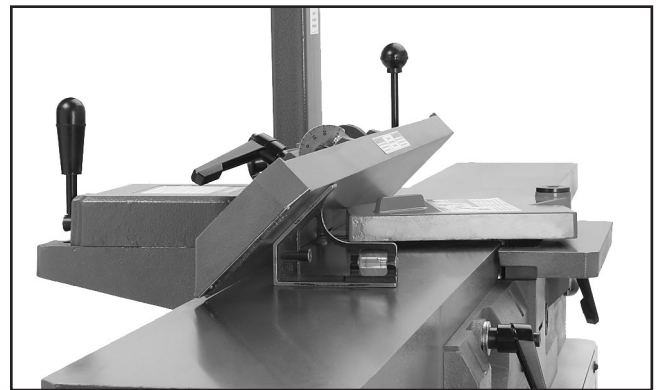

**Figure 61.** Fence adjusted 45° inward.

2. Loosen the jam nut on the 45° inward positive stop bolt shown in **Figure 62**.

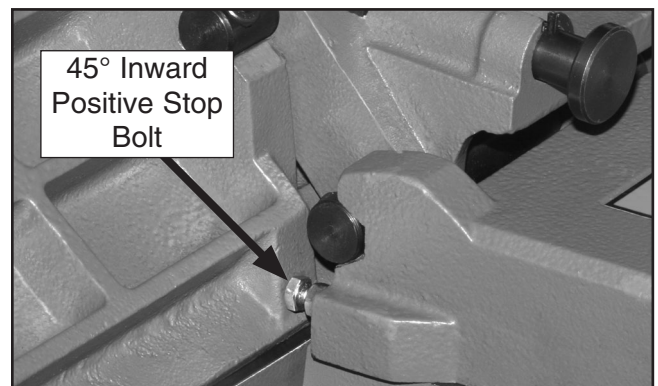

**Figure 62.** 45° inward positive stop bolt.

3. Adjust the positive stop bolt until the fence is exactly 45° inward while resting on the bolt (verify the angle with a 45° square).
4. Retighten the jam nut loosened in **Step 2**.



### To set the 90° fence stop:

1. Loosen the set screw in the plunger lock collar, shown in **Figure 63**, and loosen the fence tilt lock.
2. Using a 90° square, adjust the fence to the 90° position, as shown in **Figure 63**.

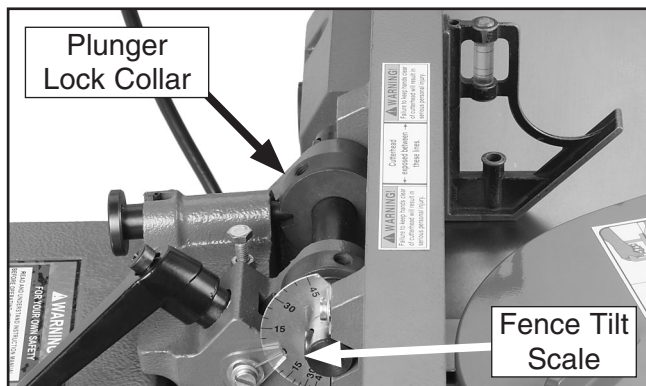

**Figure 63.** Adjusting fence to 90°.

3. Tighten the set screw in the plunger lock collar.
4. Adjust the indicator (if necessary) to 0° to calibrate the fence tilt scale.

### To set the 45° outward fence stop:

1. Loosen the fence tilt lock, and position the fence against the 45° outward positive stop bolt.
2. Loosen the jam nut on the 45° outward fence positive stop bolt (**Figure 64**).

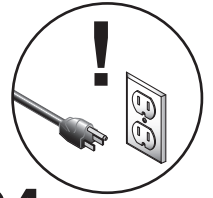

**Figure 64.** Adjusting fence 45° outward.

3. Adjust the 45° outward positive stop bolt until the fence is exactly 45° outward while resting on the bolt (check the angle with a sliding bevel set to 135°).
4. Retighten the jam nut loosened in **Step 2**.



# Wiring Diagram



## MODEL G0604 110V OPERATION

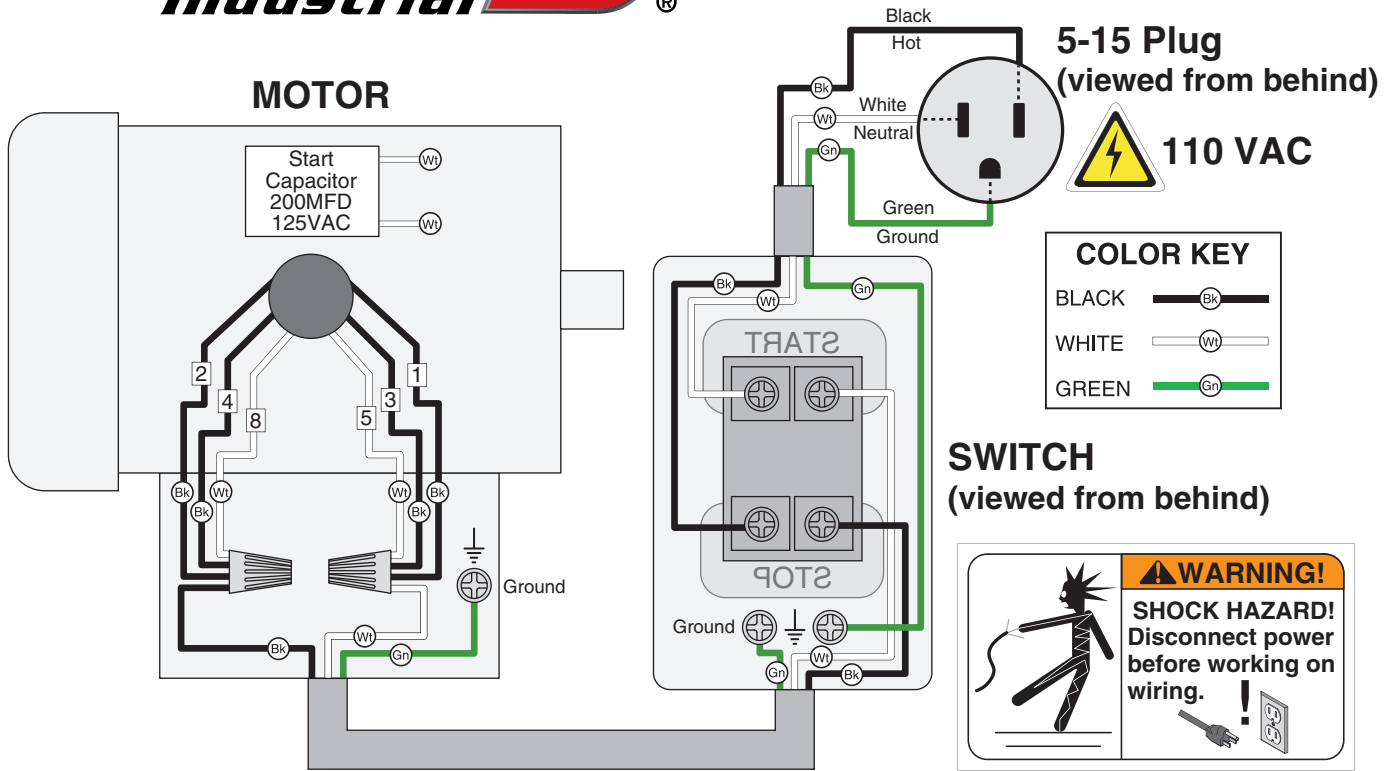

## Electrical Components

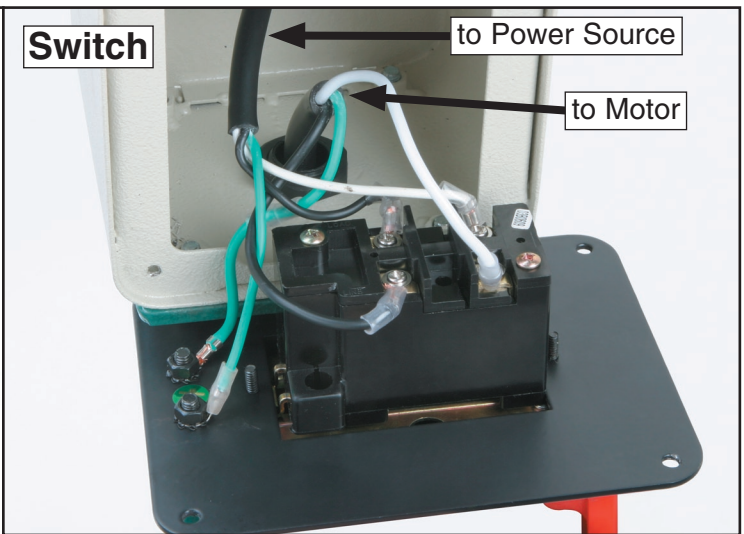
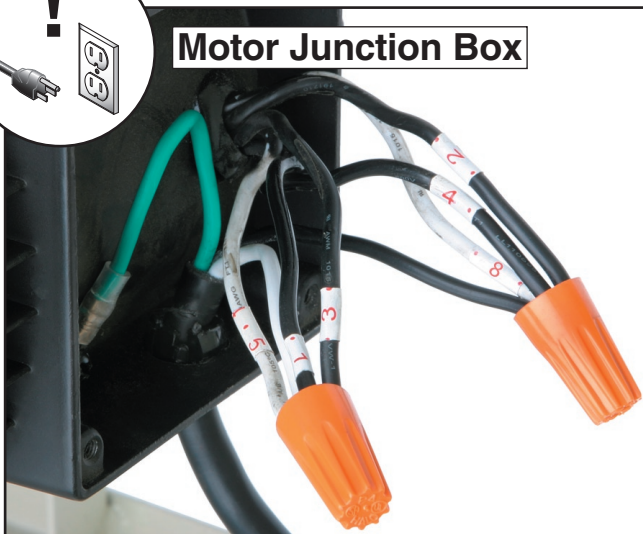
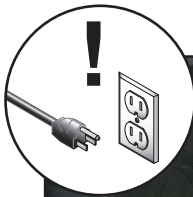

# Jointer Parts Breakdown

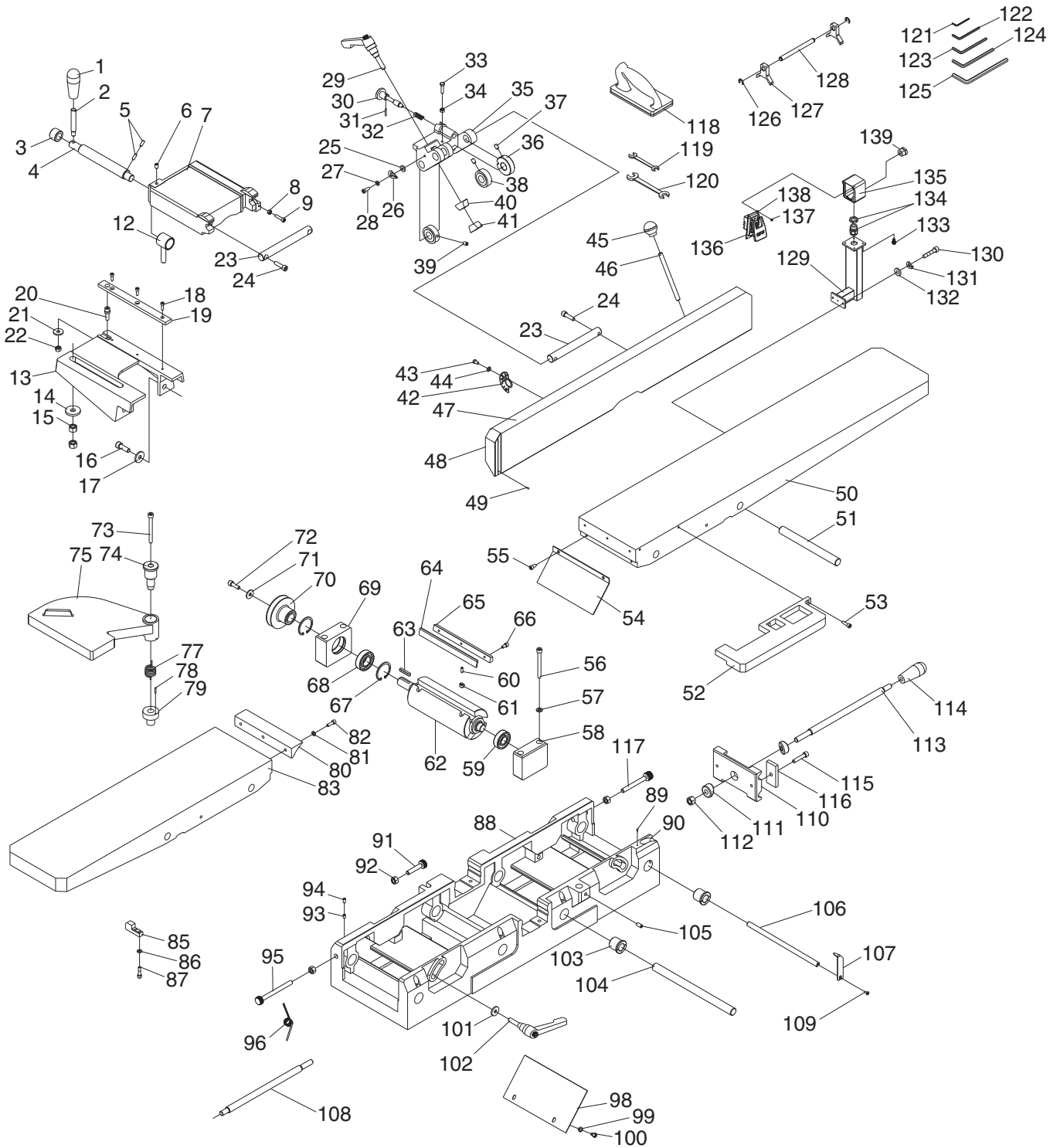

# Jointer Parts List

REF	PART #	DESCRIPTION
1	P0604001	HANDLE
2	P0604002	STUD
3	P0604003	BUSHING
4	P0604004	SHAFT
5	PSS11M	SET SCREW M6-1 X 16
6	PSS16M	SET SCREW M8-1.25 X 10
7	P0604007	CARRIAGE
8	PN01M	HEX NUT M6-1
9	PSB06M	CAP SCREW M6-1 X 25
12	P0604012	COLLAR
13	P0604013	SUPPORT
14	PW06M	FLAT WASHER 12MM
15	PN09M	HEX NUT M12-1.75
16	PSB72M	CAP SCREW M10-1.5 X 30
17	PW04M	FLAT WASHER 10MM
18	PSB24M	CAP SCREW M5-.8 X 16
19	P0604019	GIB
20	P0604020	ECCENTRIC
21	PW01M	FLAT WASHER 8MM
22	PN03M	HEX NUT M8-1.25
23	P0604023	SHAFT
24	PSB13M	CAP SCREW M8-1.25 X 30
25	PW03M	FLAT WASHER 6MM
26	P0604026	POINTER
27	PW03M	FLAT WASHER 6MM
28	PSB115M	BUTTON HD CAP SCR M6-1 X 16
29	P0604029	ADJUSTABLE HANDLE
30	P0604030	INDEX PIN ASSY
31	PRP42M	ROLL PIN 3 X 20
32	P0604032	COMPRESSION SPRING
33	PB10M	HEX BOLT M6-1 X 25
34	PN01M	HEX NUT M6-1
35	P0604035	SWIVEL
36	P0604036	COLLAR
37	PSS16M	SET SCREW M8-1.25 X 10
38	P0604038	LOCK
39	PSS14M	SET SCREW M8-1.25 X 12
40	P0604040	CLAMP
41	P0604041	CLAMP
42	P0604042	SCALE

REF	PART #	DESCRIPTION
43	PS68M	PHLP HD SCR M6-1 X 10
44	PW03M	FLAT WASHER 6MM
45	P0604045	BALL HANDLE
46	P0604046	STUD
47	P0604047	FENCE
48	P0604048	SCALE
49	P0604049	RIVET
50	P0604050	TABLE RH
51	P0604051	TABLE SHAFT
52	P0604052	RABBETING TABLE EXT
53	PSB02M	CAP SCREW M6-1 X 20
54	P0604054	CHIP DEFLECTOR
55	PSB33M	CAP SCREW M5-.8 X 12
56	PSB148M	CAP SCREW M8-1.25 X 80
57	PLW04M	LOCK WASHER 8MM
58	P0604058	BEARING BLOCK LEFT
59	P6004	BALL BEARING 6004ZZ
60	PSS34M	SET SCREW M5-.8 X 16
61	P0604061	KNIFE LIFTER SPRING
62	P0604062	CUTTERHEAD
63	PK74M	KEY 6 X 6 X 35
64	P0604064	SET OF (3) KNIVES
65	P0604065	KNIFE GIB
66	P0604066	GIB BOLT
67	PR24M	INT RETAINING RING 42MM
68	P6004	BALL BEARING 6004ZZ
69	P0604069	BEARING BLOCK RIGHT
70	P0604070	CUTTERHEAD PULLEY
71	PW01M	FLAT WASHER 8MM
72	PSB31M	CAP SCREW M8-1.25 X 25
73	PSB148M	CAP SCREW M8-1.25 X 80
74	P0604074	GUARD CLAMP
75	P0604075	CUTTERHEAD GUARD
77	P0604077	TORSION SPRING
78	PRP02M	ROLL PIN 3 X 16
79	P0604079	SUPPORT
80	P0604080	TABLE LIP
81	PW02M	FLAT WASHER 5MM
82	PSB24M	CAP SCREW M5-.8 X 16
83	P0604083	TABLE LH



# Jointer Parts List

REF	PART #	DESCRIPTION
85	P0604085	BUMPER
86	PW03M	FLAT WASHER 6MM
87	PSB07M	CAP SCREW M6-1 X 30
88	P0604088	BASE
89	P0604089	RIVET
90	P0604090	SCALE
91	P0604091	ADJUSTMENT SCREW
92	PN02M	HEX NUT M10-1.5
93	PSS01M	SET SCREW M6-1 X 10
94	PSS01M	SET SCREW M6-1 X 10
95	P0604095	ADJUSTMENT SCREW
96	P0604096	EXTENSION SPRING
98	P0604098	CHIPBREAKER
99	PW03M	FLAT WASHER 6MM
100	PB02M	HEX BOLT M6-1 X 12
101	PW01M	FLAT WASHER 8MM
102	P0604102	ADJUSTABLE HANDLE
103	P0604103	ECCENTRIC BUSHING
104	P0604104	TABLE SHAFT
105	PSS14M	SET SCREW M8-1.25 X 12
106	P0604106	TABLE SHAFT
107	P0604107	POINTER
108	P0604108	LEVER
109	PFH07M	FLAT HD SCR M5-.8 X 10
110	P0604110	PIVOT BRACKET
111	P0604111	ADJUSTING BLOCK
112	PN09M	HEX NUT M12-1.75

REF	PART #	DESCRIPTION
113	P0604113	LEVER
114	P0604114	HANDLE
115	PSB12M	CAP SCREW M8-1.25 X 40
116	P0604116	CLAMP PLATE
117	P0604117	MEDIUM ADJUSTMENT SCR
118	P0604118	PUSH BLOCK
119	P0604119	OPEN END WRENCH 8/10MM
120	P0604120	OPEN END WRENCH 12/14MM
121	PAW02.5M	HEX WRENCH 2.5MM
122	PAW04M	HEX WRENCH 4MM
123	PAW05M	HEX WRENCH 5MM
124	PAW06M	HEX WRENCH 6MM
125	PAW08M	HEX WRENCH 8MM
126	PEC015M	E-CLIP 8MM
127	P0604127	KNIFE GAUGE BLOCK
128	P0604128	KNIFE GAUGE ROD 120MM
129	P0604129	SWITCH PEDESTAL
130	PSB31M	CAP SCREW M8-1.25 X 25
131	PLW04M	LOCK WASHER 8MM
132	PW01M	FLAT WASHER 8MM
133	P0604133	FLANGE BOLT M6-1 X 16
134	P0604134	BALL STRAIN RELIEF 13.5MM
135	P0604135	SWITCH BOX
136	P0604136	SWITCH ASSEMBLY'
137	PHTEK4M	TAP SCREW M4 X 8
138	P0604138	SWITCH BRACKET
139	P0604139	STRAIN RELIEF



# Stand/Motor Parts Breakdown

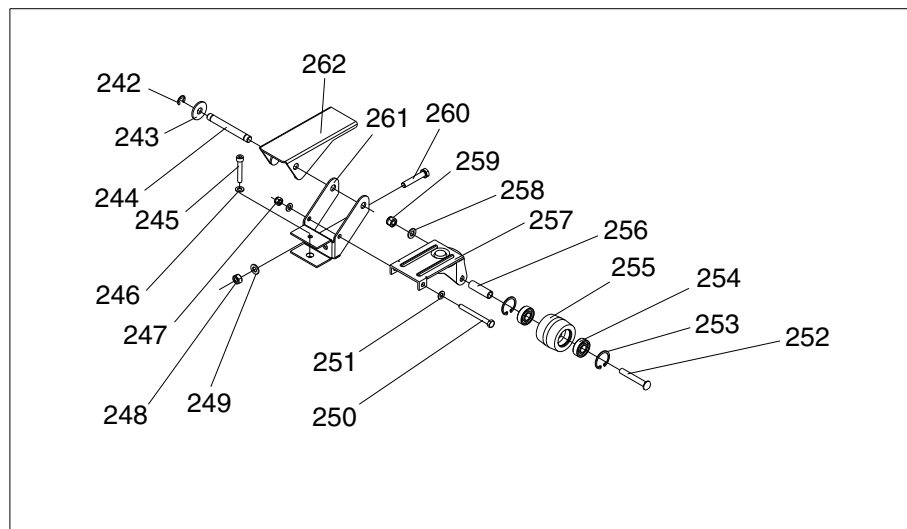
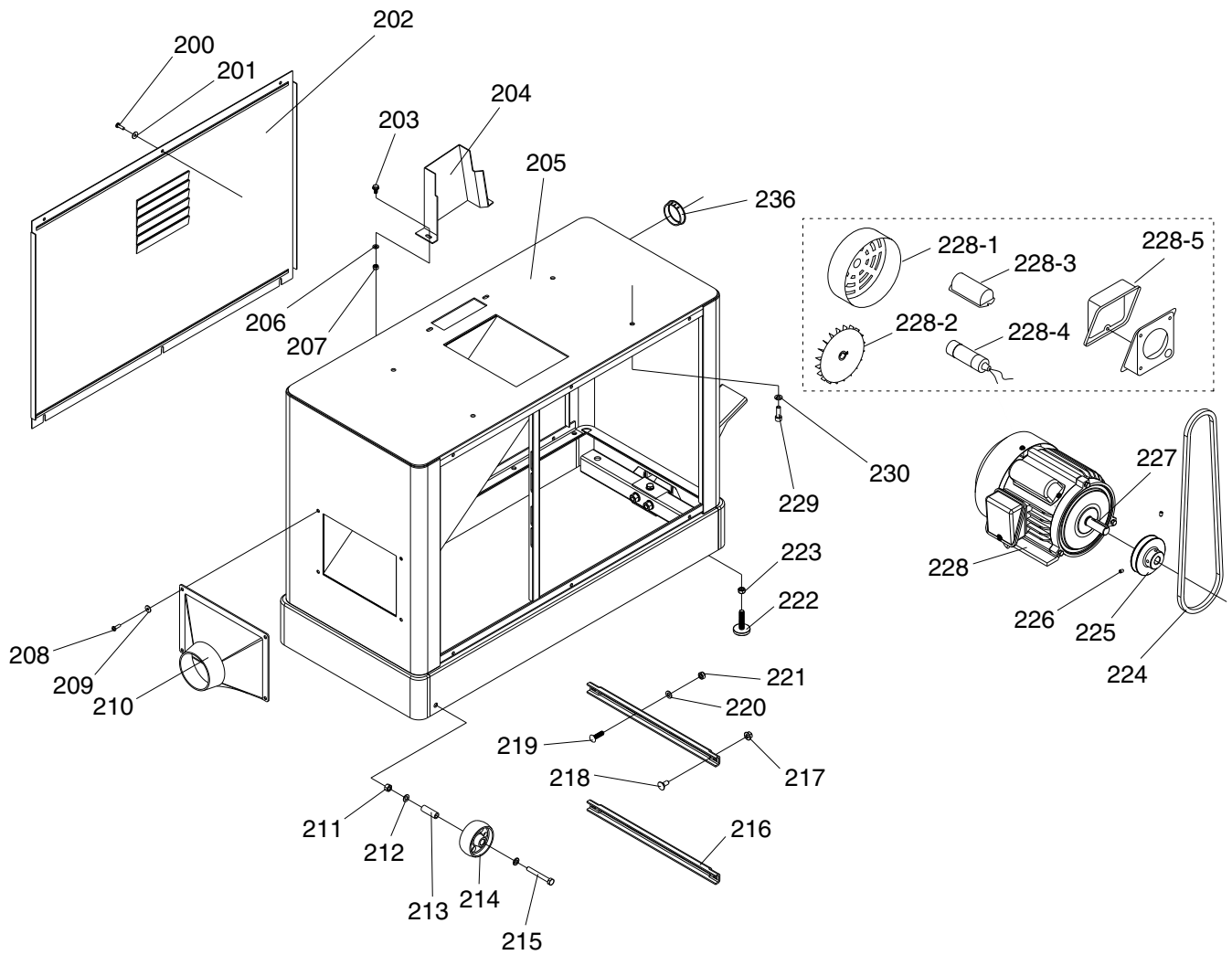

# Stand/Motor Parts List

REF	PART #	DESCRIPTION
200	PS40M	PHLP HD SCR M5-.8 X 16
201	PW02M	FLAT WASHER 5MM
202	P0604202	PANEL
203	PFS02M	FLANGE SCREW M6-1 X 12
204	P0604204	BELT GUARD
205	P0604205	CABINET STAND
206	PW03M	FLAT WASHER 6MM
207	PN01M	HEX NUT M6-1
208	PS40M	PHLP HD SCR M5-.8 X 16
209	PW02M	FLAT WASHER 5MM
210	P0604210	DUST PORT
211	PN03M	HEX NUT M8-1.25
212	PW01M	FLAT WASHER 8MM
213	P0604213	SLEEVE
214	P0604214	WHEEL
215	PB86M	HEX BOLT M8-1.25 X 65
216	P0604216	MOTOR BRACKET
217	P0604217	FLANGE NUT 5/16-18
218	PCB05	CARRIAGE BOLT 5/16-18 X 3/4
219	PCB11	CARRIAGE BOLT 5/16-18 X 1
220	PW07	FLAT WASHER 5/16
221	P0604221	FLANGE NUT 5/16-18
222	P0604222	FOOT
223	PN08	HEX NUT 3/8-16
224	PVA40	V-BELT A-40 4L400
225	P0604225	MOTOR PULLEY
226	PSS02M	SET SCREW M6-1 X 6
227	PK12M	KEY 5 X 5 X 30
228	P0604228	MOTOR 1HP

REF	PART #	DESCRIPTION
228-1	P0604228-1	FAN COVER
228-2	P0604228-2	MOTOR FAN
228-3	P0604228-3	CAPACITOR COVER
228-4	P0604228-4	CAPACITOR 200MFD 125VAC
228-5	P0604228-5	WIRING BOX
229	PSB31M	CAP SCREW M8-1.25 X 25
230	PLW04M	LOCK WASHER 8MM
236	P0604236	STRAIN RELIEF
242	PR16M	EXT RETAINING RING 9MM
243	P0604243	SPECIAL WASHER 13MM
244	P0604244	SHAFT
245	PSB05M	CAP SCREW M8-1.25 X 50
246	PW01M	FLAT WASHER 8MM
247	PN03M	HEX NUT M8-1.25
248	PN02M	HEX NUT M10-1.5
249	PW04M	FLAT WASHER 10MM
250	PB45M	HEX BOLT M8-1.25 X 100
251	PW01M	FLAT WASHER 8MM
252	P0604252	SPECIAL BOLT
253	PR21M	INT RETAINING RING 35MM
254	P0604254	BALL BEARING 6202Z
255	P0604255	TROLLEY WHEEL
256	P0604256	SLEEVE
257	P0604257	TROLLEY BRACKET
258	PW04M	FLAT WASHER 10MM
259	PN02M	HEX NUT M10-1.5
260	PB144M	HEX BOLT M10-1.5 X 55
261	P0604261	PEDAL BRACKET
262	P0604262	PEDAL



# Warning Label Parts List

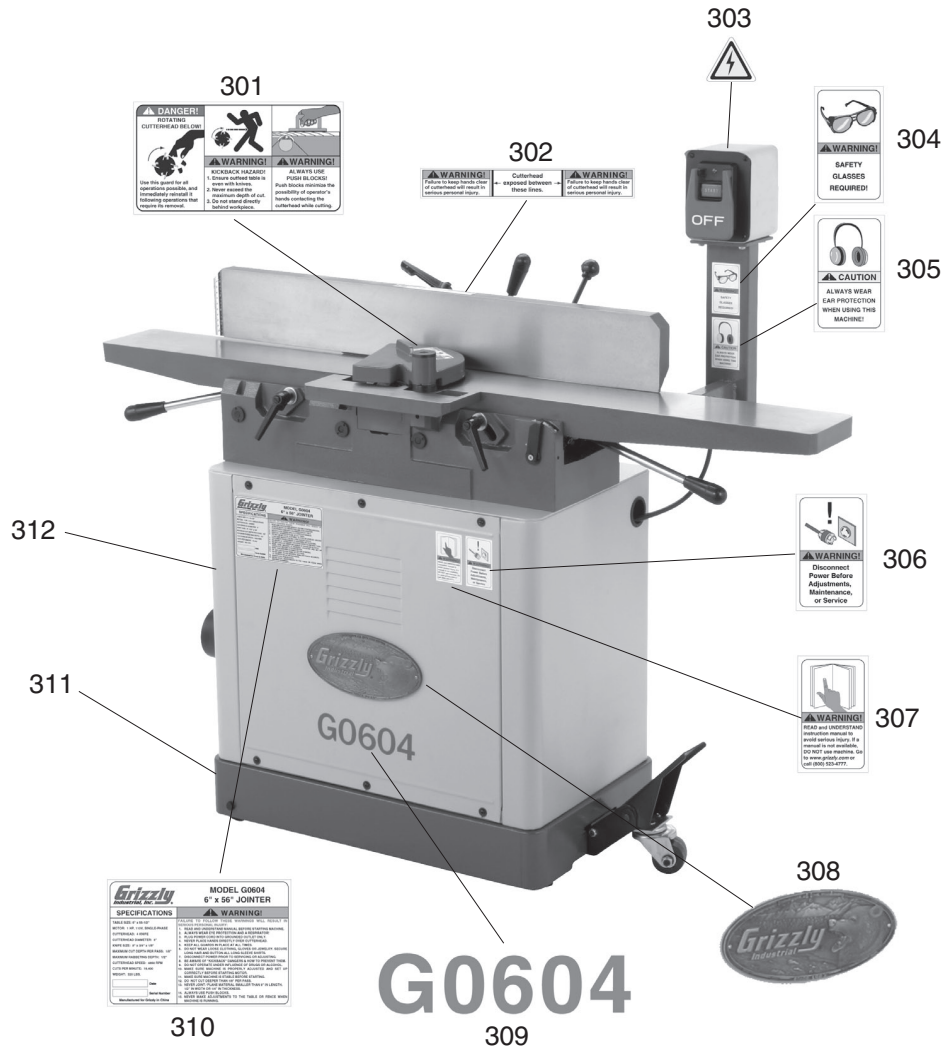

REF	PART #	DESCRIPTION
301	PLABEL-29	CUTTERHEAD GUARD LABEL
302	P0604302	CUTTERHEAD WARNING LABEL
303	PLABEL-14	ELECTRICITY LABEL
304	P0604304	SAFETY GLASSES LABEL
305	P0604305	EAR PROTECTION LABEL
306	P0604306	DISCONNENCT POWER LABEL

REF	PART #	DESCRIPTION
307	P0604307	READ MANUAL LABEL
308	P0604308	GRIZZLY NAMEPLATE
309	P0604309	MODEL # LABEL
310	P0604310	MACHINE ID LABEL
311	P0604311	"GRIZZLY GREEN" TOUCH-UP PAI
312	P0604312	"PUTTY" TOUCH-UP PAINT

## WARNING

Safety labels warn about machine hazards and ways to prevent injury. The owner of this machine **MUST** maintain the original location and readability of the labels on the machine. If any label is removed or becomes unreadable, **REPLACE** that label before using the machine again. Contact Grizzly at (800) 523-4777 or [www.grizzly.com](http://www.grizzly.com) to order new labels.



# WARRANTY AND RETURNS

---

Grizzly Industrial, Inc. warrants every product it sells for a period of **1 year** to the original purchaser from the date of purchase. This warranty does not apply to defects due directly or indirectly to misuse, abuse, negligence, accidents, repairs or alterations or lack of maintenance. This is Grizzly's sole written warranty and any and all warranties that may be implied by law, including any merchantability or fitness, for any particular purpose, are hereby limited to the duration of this written warranty. We do not warrant or represent that the merchandise complies with the provisions of any law or acts unless the manufacturer so warrants. In no event shall Grizzly's liability under this warranty exceed the purchase price paid for the product and any legal actions brought against Grizzly shall be tried in the State of Washington, County of Whatcom.

We shall in no event be liable for death, injuries to persons or property or for incidental, contingent, special, or consequential damages arising from the use of our products.

To take advantage of this warranty, contact us by mail or phone and give us all the details. We will then issue you a "Return Number," which must be clearly posted on the outside as well as the inside of the carton. We will not accept any item back without this number. Proof of purchase must accompany the merchandise.

The manufacturers reserve the right to change specifications at any time because they constantly strive to achieve better quality equipment. We make every effort to ensure that our products meet high quality and durability standards and we hope you never need to use this warranty.

Please feel free to write or call us if you have any questions about the machine or the manual.

Thank you again for your business and continued support. We hope to serve you again soon.







# WARRANTY CARD

Name \_\_\_\_\_  
 Street \_\_\_\_\_  
 City \_\_\_\_\_ State \_\_\_\_\_ Zip \_\_\_\_\_  
 Phone # \_\_\_\_\_ Email \_\_\_\_\_ Invoice # \_\_\_\_\_  
 Model # \_\_\_\_\_ Order # \_\_\_\_\_ Serial # \_\_\_\_\_

The following information is given on a voluntary basis. It will be used for marketing purposes to help us develop better products and services. **Of course, all information is strictly confidential.**

1. How did you learn about us?

Advertisement       Friend       Catalog  
 Card Deck       Website       Other: \_\_\_\_\_

2. Which of the following magazines do you subscribe to?

<input type="checkbox"/> Cabinet Maker	<input type="checkbox"/> Popular Mechanics	<input type="checkbox"/> Today's Homeowner
<input type="checkbox"/> Family Handyman	<input type="checkbox"/> Popular Science	<input type="checkbox"/> Wood
<input type="checkbox"/> Hand Loader	<input type="checkbox"/> Popular Woodworking	<input type="checkbox"/> Wooden Boat
<input type="checkbox"/> Handy	<input type="checkbox"/> Practical Homeowner	<input type="checkbox"/> Woodshop News
<input type="checkbox"/> Home Shop Machinist	<input type="checkbox"/> Precision Shooter	<input type="checkbox"/> Woodsmith
<input type="checkbox"/> Journal of Light Cont.	<input type="checkbox"/> Projects in Metal	<input type="checkbox"/> Woodwork
<input type="checkbox"/> Live Steam	<input type="checkbox"/> RC Modeler	<input type="checkbox"/> Woodworker West
<input type="checkbox"/> Model Airplane News	<input type="checkbox"/> Rifle	<input type="checkbox"/> Woodworker's Journal
<input type="checkbox"/> Modeltec	<input type="checkbox"/> Shop Notes	<input type="checkbox"/> Other: _____
<input type="checkbox"/> Old House Journal	<input type="checkbox"/> Shotgun News	

3. What is your annual household income?

\$20,000-\$29,000       \$30,000-\$39,000       \$40,000-\$49,000  
 \$50,000-\$59,000       \$60,000-\$69,000       \$70,000+

4. What is your age group?

20-29       30-39       40-49  
 50-59       60-69       70+

5. How long have you been a woodworker/metalworker?

0-2 Years       2-8 Years       8-20 Years       20+ Years

6. How many of your machines or tools are Grizzly?

0-2       3-5       6-9       10+

7. Do you think your machine represents a good value?

Yes       No

8. Would you recommend Grizzly Industrial to a friend?

Yes       No

9. Would you allow us to use your name as a reference for Grizzly customers in your area?

Note: *We never use names more than 3 times.*       Yes       No

10. Comments: \_\_\_\_\_  
 \_\_\_\_\_  
 \_\_\_\_\_  
 \_\_\_\_\_

CUT ALONG DOTTED LINE

FOLD ALONG DOTTED LINE

\_\_\_\_\_  
\_\_\_\_\_  
\_\_\_\_\_



Place  
Stamp  
Here



**GRIZZLY INDUSTRIAL, INC.**  
**P.O. BOX 2069**  
**BELLINGHAM, WA 98227-2069**



FOLD ALONG DOTTED LINE

Send a Grizzly Catalog to a friend:

Name \_\_\_\_\_  
Street \_\_\_\_\_  
City \_\_\_\_\_ State \_\_\_\_\_ Zip \_\_\_\_\_

TAPE ALONG EDGES--PLEASE DO NOT STAPLE







# *grizzly.com*

**TOOL WEBSITE**

Buy Direct and Save with Grizzly® – Trusted, Proven and a Great Value!

*Visit Our Website Today And Discover Why  
Grizzly® Is The Industry Leader!*

- SECURE ORDERING
- ORDERS SHIPPED WITHIN 24 HOURS
- E-MAIL RESPONSE WITHIN ONE HOUR

-OR-

Call Today For A **FREE**  
Full Color Catalog

**1-800-523-4777**

