



INSTRUCTION SHEET

Model G0593

Spiral Cutterhead 8" x 75" Jointer

INTRODUCTION

The Model G0593 is the spiral cutterhead version of the G0586. Except for differences noted in this insert, all other content in the Model G0586 owner's manual applies to this machine. Before operating your new machine, you **MUST** read and understand this insert and the entire Model G0586 manual to reduce the risk of injury when using this machine.

If you have any questions about this manual insert or the differences between these two models, contact our Technical Support at (570) 546-9663 or email techsupport@grizzly.com.

The spiral cutterhead consists of 36 indexable carbide inserts. Each insert has four cutting edges, which can be easily rotated if the current cutting edge becomes dull or damaged.

INVENTORY

For the Model G0593, use the inventory list from the Model G0586, but exchange the standard cutterhead parts for the parts below:

Flat-Head Torx Screws.....	10
Torx Screw Driver T-Handle 6mm.....	1
Torx Bits T-25.....	5
Carbide Inserts.....	5

REPLACING or ROTATING INSERTS

To replace or rotate the inserts:

1. **Disconnect the jointer from the power source.**
2. Clean out the heads of the insert Torx screws that you wish to replace or rotate.
3. Remove the Torx screw, replace or rotate the insert, lubricate the threads of the Torx screw with a light machine oil, and torque the screw to 50 inch pounds to tighten the insert.

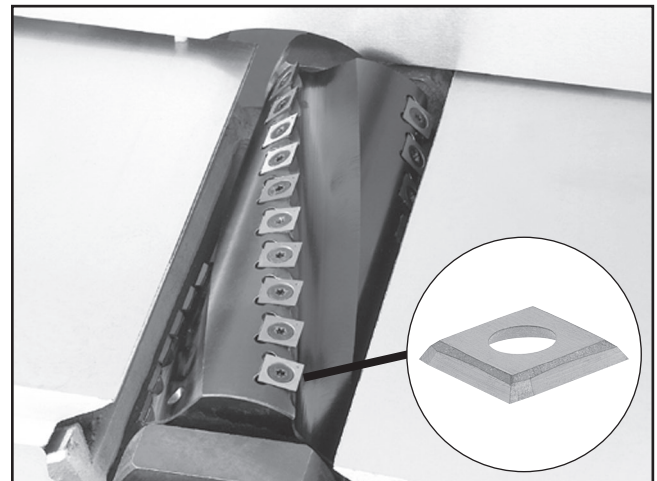

Figure 1. Spiral cutterhead and close up of carbide insert.

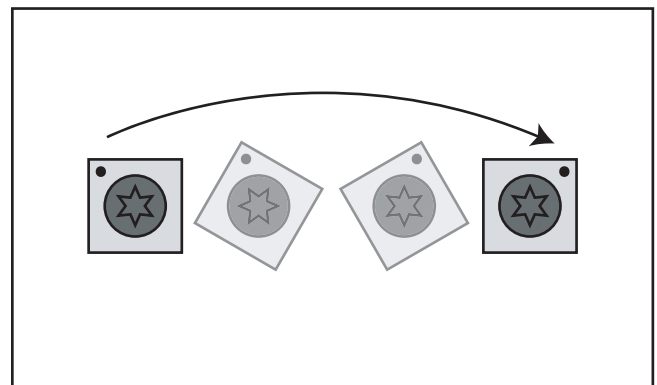

Figure 2. Rotating indexable carbide inserts.

NOTICE

Make sure there is no wood dust or debris under insert when replacing it.

NOTICE

Over-tightening Torx screws may strip the cutterhead threads!

Model G0593 Replacement Parts

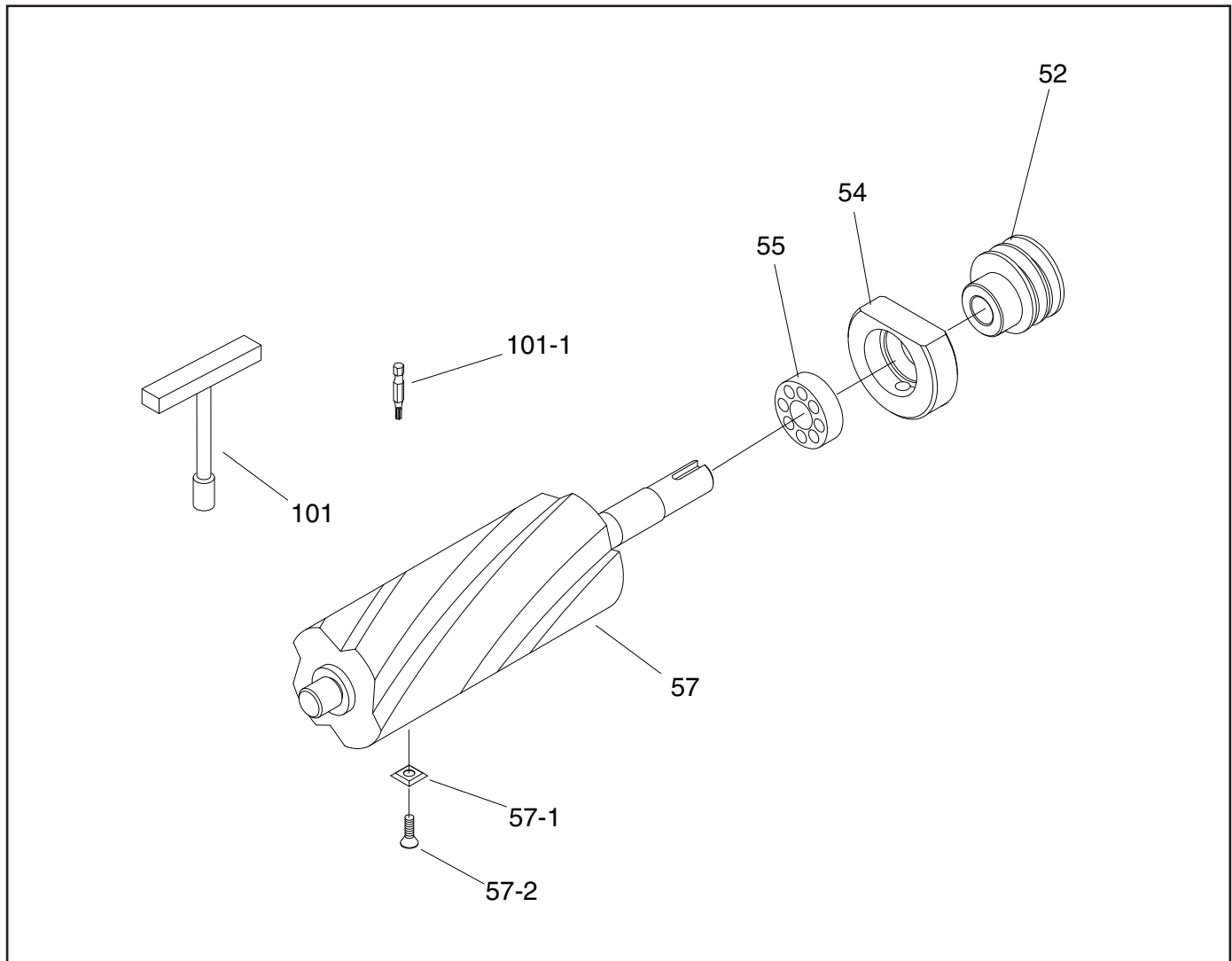

REF	PART #	DESCRIPTION
52	P0593052	2 SHEAVE CUTTERHEAD PULLEY
54	P0593054	BEARING BLOCK
55	P6205	BALL BEARING 6205
57A	P0593057A	SPIRAL CUTTERHEAD 8" V2.03.08
57A-1	P0593057A-1	INDEXABLE CARBIDE INSERT V2.03.08
57A-2	P0593057A-2	FLAT HD TORX SCR 10-32 X 1/2
101	P0593101	TORX T-HANDLE DRIVER 6MM
101-1A	P0593101-1A	TORX BIT T-25

NOTICE

All parts for the Model G0593, except those shown above, are the same as the Model G0586. Therefore, please use the included Model G0586 Manual when ordering new parts for your machine, unless those parts are shown above.

COPYRIGHT © MAY, 2005. BY GRIZZLY INDUSTRIAL, INC. REVISED MARCH, 2008 (TR)
**WARNING: NO PORTION OF THIS MANUAL MAY BE REPRODUCED IN ANY SHAPE
OR FORM WITHOUT THE WRITTEN APPROVAL OF GRIZZLY INDUSTRIAL, INC.**

#TR7280 PRINTED IN CHINA

Grizzly **Industrial, Inc.**®

8" X 75" DELUXE JOINTER MODEL G0586 INSTRUCTION MANUAL



COPYRIGHT © MARCH, 2005 BY GRIZZLY INDUSTRIAL, INC.

**WARNING: NO PORTION OF THIS MANUAL MAY BE REPRODUCED IN ANY SHAPE
OR FORM WITHOUT THE WRITTEN APPROVAL OF GRIZZLY INDUSTRIAL, INC.**

#TR6958 PRINTED IN CHINA

WARNING

Some dust created by power sanding, sawing, grinding, drilling, and other construction activities contains chemicals known to the State of California to cause cancer, birth defects or other reproductive harm. Some examples of these chemicals are:

- Lead from lead-based paints.
- Crystalline silica from bricks, cement, and other masonry products.
- Arsenic and chromium from chemically treated lumber.

Your risk from these exposures varies, depending on how often you do this type of work. To reduce your exposure to these chemicals: work in a well ventilated area, and work with approved safety equipment, such as those dust masks that are specially designed to filter out microscopic particles.

Table of Contents

INTRODUCTION	3
Foreword	3
Contact Info	3
Identification	5
SECTION 1: SAFETY	6
Safety Instructions for Machinery	6
Additional Safety for Jointers	8
SECTION 2: CIRCUIT REQUIREMENTS	9
220V Single-Phase	9
SECTION 3: SET UP	10
Set Up Safety	10
Items Needed for Set Up	10
Unpacking	10
Inventory.....	11
Clean Up	12
Site Considerations	12
Mounting Jointer.....	13
V-Belt.....	13
Fence Tilt Lever	14
Dust Port	14
Cutterhead Guard	15
Switch Components	15
Handwheels.....	17
Knife Setting Jig	17
Test Run.....	18
Recommended Adjustments	18
SECTION 4: OPERATIONS	19
Operation Safety	19
Stock Inspection and Requirements	19
Squaring Stock.....	20
Surface Planing.....	21
Edge Jointing	22
Bevel Cutting.....	23
Rabbet Cutting	24
SECTION 5: ACCESSORIES	25
SECTION 6: MAINTENANCE	28
Schedule	28
V-Belts.....	28
Cleaning	28
Lubrication.....	28

SECTION 7: SERVICE	29
About Service	29
Inspecting Knives	29
Setting Knives	29
Setting Outfeed Table Height.....	31
Calibrating Depth Scale	31
Setting Fence Stops.....	32
Adjusting Gibs	33
Wiring Diagram	34
G0586 Electrical Components	35
Troubleshooting Guide	36
Jointer Parts Breakdown	38
Jointer Parts List	39
Stand/Motor Parts Breakdown	40
Stand/Motor Parts List.....	41
WARRANTY AND RETURNS	42

INTRODUCTION

Foreword

We are proud to offer the Model G0586 8" X 75" Deluxe Jointer. This machine is part of a growing Grizzly family of fine woodworking machinery. When used according to the guidelines set forth in this manual, you can expect years of trouble-free, enjoyable operation and proof of Grizzly's commitment to customer satisfaction.

We are pleased to provide this manual with the Model G0586. It was written to guide you through assembly, review safety considerations, and cover general operating procedures. It represents our effort to produce the best documentation possible.

The specifications, drawings, and photographs illustrated in this manual represent the Model G0586 as supplied when the manual was prepared. However, owing to Grizzly's policy of continuous improvement, changes may be made at any time with no obligation on the part of Grizzly. For your convenience, we always keep current Grizzly manuals available on our website at **www.grizzly.com**. Any updates to your machine will be reflected in these manuals as soon as they are complete. Visit our site often to check for the latest updates to this manual!



Contact Info

If you have any comments regarding this manual, please write to us at the address below:

Grizzly Industrial, Inc.
c/o Technical Documentation Manager
P.O. Box 2069
Bellingham, WA 98227-2069

We stand behind our machines. If you have any service questions or parts requests, please call or write us at the location listed below.

Grizzly Industrial, Inc.
1203 Lycoming Mall Circle
Muncy, PA 17756
Phone: (570) 546-9663
Fax: (800) 438-5901
E-Mail: techsupport@grizzly.com
Web Site: <http://www.grizzly.com>





MACHINE DATA SHEET

Customer Service #: (570) 546-9663 • To Order Call: (800) 523-4777 • Fax #: (800) 438-5901

MODEL G0586 8" X 75" DELUXE JOINTER

Design Type:..... Cabinet

Overall Dimensions:

Table Size 8" W x 75" L
 Height (from floor to table) 31"
 Overall Length 75½"
 Overall Width 24"
 Shipping Weight 546 lbs.
 Net Weight 418 lbs.
 1st Box Size 80" x 24½" x 14"
 2nd Box Size 25¾" x 23¾" x 17¾"
 Stand Footprint 23½" x 16¾"
 Cutterhead Diameter 3¼"

Capacities:

Maximum Rabbeting Capacity ½"
 Maximum Depth of Cut (per pass) ⅛"
 Maximum Width of Cut 8"
 Cutterhead Speed 5000 RPM
 Cuts Per Minute 20,000

Construction:

Tables Independently Adjustable, Precision Ground Cast Iron
 Ways Dovetailed, Adjustable
 Fence Assembly Cast Iron
 Body Assembly Cast Iron
 Stand One Piece Steel Cabinet
 Cutterhead 3" Diameter, 4-Knife
 Cutterhead Knife Size 8" x ⅛" x ¾"
 Guard Die Cast Metal
 Bearings Shielded and Lubricated

Motor:

Type TEFC Capacitor Start Induction
 Horsepower 2 HP
 Phase / Voltage Single-Phase 220V
 Amps 15A
 Cycle / RPM 60 Hertz / 3450 RPM
 Switch Magnetic w/Thermal Overload Protection
 Power Transfer Double V-Belt Drive
 Bearings Shielded & Lubricated Ball Bearings

Features:

..... Handwheel Controlled Fence Adjustment
 Top Mount Switch Controls
 Super Long 75" Bed
 Included 4" Dust Port

Specifications, while deemed accurate, are not guaranteed.

Identification

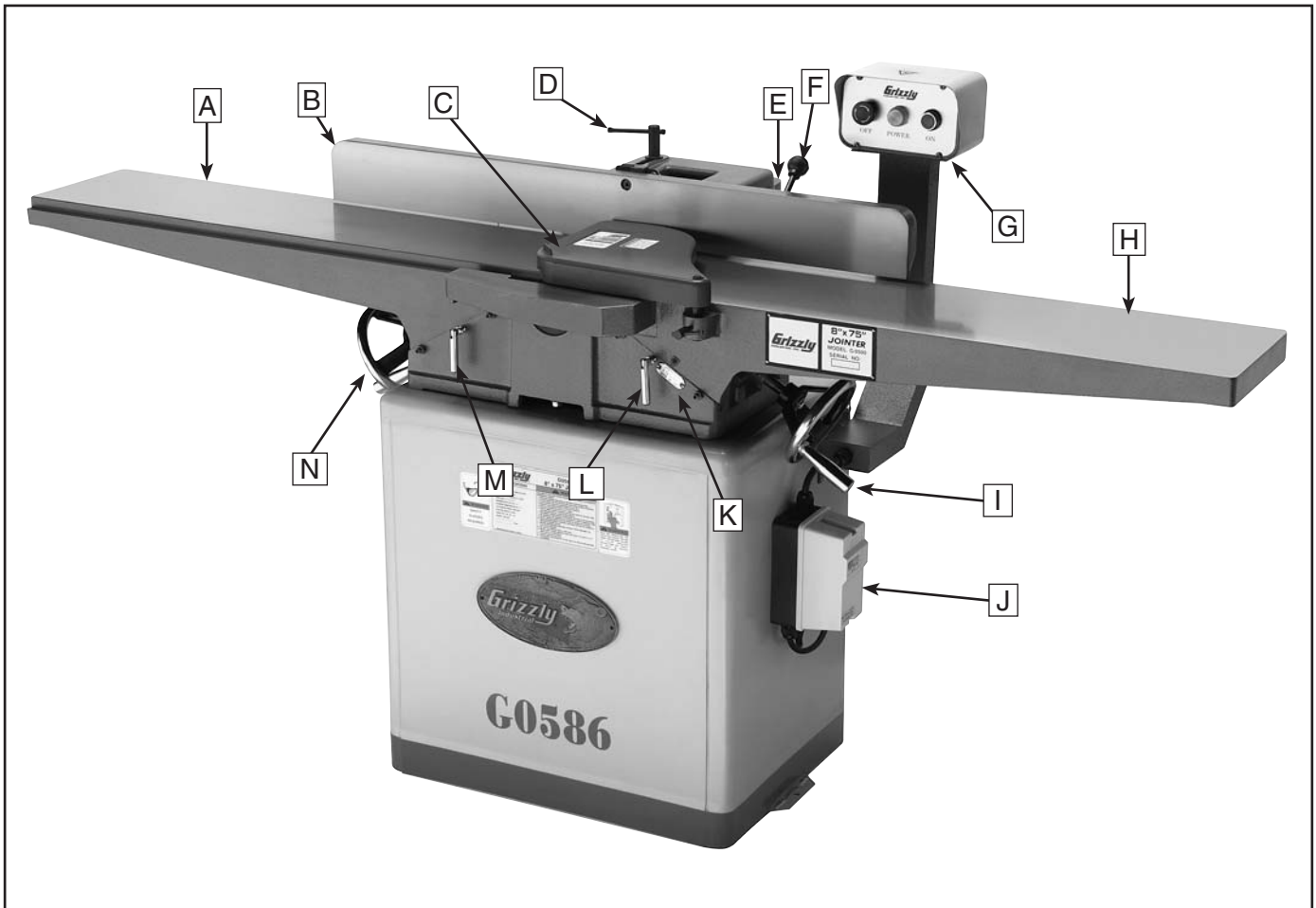

- A. Outfeed Table
- B. Fence
- C. Cutterhead Guard
- D. Fence Lock
- E. Fence Adjustment Knob
- F. Fence Tilt Handle
- G. Control Panel
- H. Infeed Table
- I. Infeed Table Handwheel
- J. Magnetic Switch
- K. Depth Scale
- L. Infeed Table Lock
- M. Outfeed Table Lock
- N. Outfeed Table Handwheel



SECTION 1: SAFETY

WARNING

For Your Own Safety, Read Instruction Manual Before Operating this Machine

The purpose of safety symbols is to attract your attention to possible hazardous conditions. This manual uses a series of symbols and signal words which are intended to convey the level of importance of the safety messages. The progression of symbols is described below. Remember that safety messages by themselves do not eliminate danger and are not a substitute for proper accident prevention measures.

 **DANGER** Indicates an imminently hazardous situation which, if not avoided, WILL result in death or serious injury.

 **WARNING** Indicates a potentially hazardous situation which, if not avoided, COULD result in death or serious injury.

 **CAUTION** Indicates a potentially hazardous situation which, if not avoided, MAY result in minor or moderate injury. It may also be used to alert against unsafe practices.

NOTICE This symbol is used to alert the user to useful information about proper operation of the machine.

WARNING

Safety Instructions for Machinery

- 1. READ THROUGH THE ENTIRE MANUAL BEFORE STARTING MACHINERY.** Machinery presents serious injury hazards to untrained users.
- 2. ALWAYS USE ANSI APPROVED SAFETY GLASSES WHEN OPERATING MACHINERY.** Everyday eyeglasses only have impact resistant lenses, they are NOT safety glasses.
- 3. ALWAYS WEAR AN ANSI APPROVED RESPIRATOR WHEN OPERATING MACHINERY THAT PRODUCES DUST.** Wood dust is a carcinogen and can cause cancer and severe respiratory illnesses.
- 4. ALWAYS USE HEARING PROTECTION WHEN OPERATING MACHINERY.** Machinery noise can cause permanent hearing damage.
- 5. WEAR PROPER APPAREL. DO NOT** wear loose clothing, gloves, neckties, rings, or jewelry which may get caught in moving parts. Wear protective hair covering to contain long hair and wear non-slip footwear.
- 6. NEVER OPERATE MACHINERY WHEN TIRED, OR UNDER THE INFLUENCE OF DRUGS OR ALCOHOL.** Be mentally alert at all times when running machinery.

WARNING

Safety Instructions for Machinery

7. **ONLY ALLOW TRAINED AND PROPERLY SUPERVISED PERSONNEL TO OPERATE MACHINERY.** Make sure operation instructions are safe and clearly understood.
8. **KEEP CHILDREN AND VISITORS AWAY.** Keep all children and visitors a safe distance from the work area.
9. **MAKE WORKSHOP CHILD PROOF.** Use padlocks, master switches, and remove start switch keys.
10. **NEVER LEAVE WHEN MACHINE IS RUNNING.** Turn power OFF and allow all moving parts to come to a complete stop before leaving machine unattended.
11. **DO NOT USE IN DANGEROUS ENVIRONMENTS.** DO NOT use machinery in damp, wet locations, or where any flammable or noxious fumes may exist.
12. **KEEP WORK AREA CLEAN AND WELL LIT.** Clutter and dark shadows may cause accidents.
13. **USE A GROUNDED EXTENSION CORD RATED FOR THE MACHINE AMPERAGE.** Undersized cords overheat and lose power. Replace extension cords if they become damaged. DO NOT use extension cords for 220V machinery.
14. **ALWAYS DISCONNECT FROM POWER SOURCE BEFORE SERVICING MACHINERY.** Make sure switch is in OFF position before reconnecting.
15. **MAINTAIN MACHINERY WITH CARE.** Keep blades sharp and clean for best and safest performance. Follow instructions for lubricating and changing accessories.
16. **MAKE SURE GUARDS ARE IN PLACE AND WORK CORRECTLY BEFORE USING MACHINERY.**
17. **REMOVE ADJUSTING KEYS AND WRENCHES.** Make a habit of checking for keys and adjusting wrenches before turning machinery ON.
18. **CHECK FOR DAMAGED PARTS BEFORE USING MACHINERY.** Check for binding and alignment of parts, broken parts, part mounting, loose bolts, and any other conditions that may affect machine operation. Repair or replace damaged parts.
19. **USE RECOMMENDED ACCESSORIES.** Refer to the instruction manual for recommended accessories. The use of improper accessories may cause risk of injury.
20. **DO NOT FORCE MACHINERY.** Work at the speed for which the machine or accessory was designed.
21. **SECURE WORKPIECE.** Use clamps or a vise to hold the workpiece when practical. A secured workpiece protects your hands and frees both hands to operate the machine.
22. **DO NOT OVERREACH.** Keep proper footing and balance at all times.
23. **MANY MACHINES WILL EJECT THE WORKPIECE TOWARD THE OPERATOR.** Know and avoid conditions that cause the workpiece to "kickback."
24. **ALWAYS LOCK MOBILE BASES (IF USED) BEFORE OPERATING MACHINERY.**
25. **BE AWARE THAT CERTAIN WOODS MAY CAUSE AN ALLERGIC REACTION** in people and animals, especially when exposed to fine dust. Make sure you know what type of wood dust you will be exposed to and always wear an approved respirator.

WARNING

Additional Safety for Jointers

- 1. JOINTER KICKBACK.** "Kickback" is when the workpiece is thrown off the jointer table by the force of the cutterhead. Always use push blocks and safety glasses to reduce the likelihood of injury from "kickback." If you do not understand what kickback is, or how it occurs, DO NOT operate this machine.
- 2. CUTTERHEAD ALIGNMENT.** Keep the top edge of the outfeed table aligned with the edge of the knife at top dead center (TDC) to avoid kickback and personal injuries.
- 3. PUSH BLOCKS.** Always use push blocks whenever surface planing. Never pass your hands directly over the cutterhead without a push block.
- 4. WORKPIECE SUPPORT.** Supporting the workpiece adequately at all times while cutting is crucial for making safe cuts and avoiding injury. Never attempt to make a cut with an unstable workpiece.
- 5. KICKBACK ZONE.** The "kickback zone" is the path directly through the end of the infeed table. Never stand or allow others to stand in this area during operation.
- 6. MAXIMUM CUTTING DEPTH.** The maximum cutting depth for one pass is $\frac{1}{8}$ ". Never attempt any single cut deeper than this!
- 7. JOINTING WITH THE GRAIN.** Jointing against the grain or jointing end grain is dangerous and could produce chatter or excessive chip out. Always joint with the grain.
- 8. KEEPING GUARDS IN PLACE.** With the exception of rabbeting, all operations must be performed with the guard in place. After rabbeting, be sure to replace the guard.
- 9. PROPER CUTTING.** When cutting, always keep the workpiece moving toward the outfeed table until the workpiece has passed completely over the cutterhead. Never back the work toward the infeed table.
- 10. USING GOOD STOCK.** Jointing safety begins with your lumber. Inspect your stock carefully before you feed it over the cutterhead. Never joint a board that has loose knots, nails, or staples. If you have any doubts about the stability or structural integrity of your stock, DO NOT joint it!

WARNING

Like all machines there is danger associated with the Model G0586. Accidents are frequently caused by lack of familiarity or failure to pay attention. Use this machine with respect and caution to lessen the possibility of operator injury. If normal safety precautions are overlooked or ignored, serious personal injury may occur.

CAUTION

No list of safety guidelines can be complete. Every shop environment is different. Always consider safety first, as it applies to your individual working conditions. Use this and other machinery with caution and respect. Failure to do so could result in serious personal injury, damage to equipment, or poor work results.

SECTION 2: CIRCUIT REQUIREMENTS

220V Single-Phase

⚠️ WARNING

Serious personal injury could occur if you connect the machine to the power source before you have completed the set up process. DO NOT connect the machine to the power source until instructed to do so.

Amperage Draw

The 2 HP motor on the Model G0586 will draw the following amps:

Motor Load at 220V 15 Amps

Circuit Requirements

Only connect your machine to a circuit that meets the requirements below. Always check to see if the wires and circuit breaker in your circuit are capable of handling the amperage draw from your machine, as well as any other machines that could be operating on the same circuit. If you are unsure, consult a qualified electrician.

Minimum Circuit Requirement 20 Amp

Plug/Receptacle Type

Recommended Plug/Receptacle.... NEMA L6-20

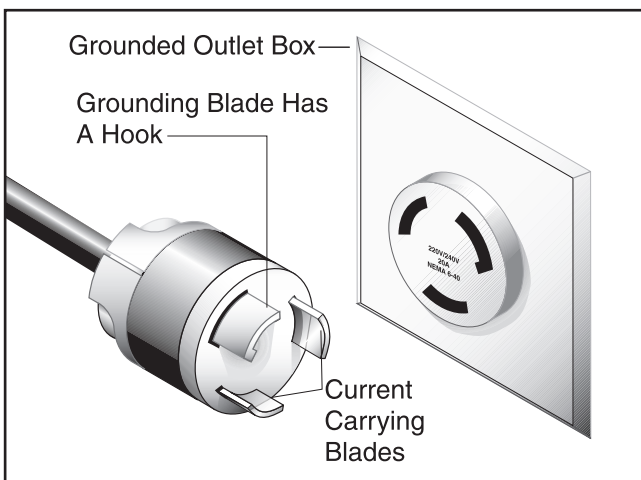
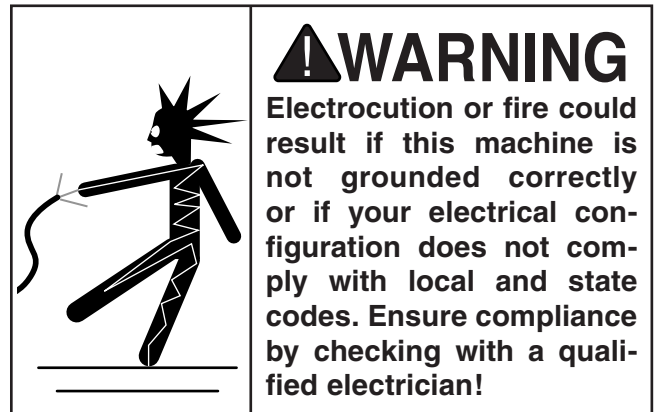

Figure 1. NEMA 6-20 plug and receptacle.

Grounding

In the event of an electrical short, grounding reduces the risk of electric shock. This tool is equipped with a power cord that has a grounding wire, which must be properly connected to the grounding prong on the plug; likewise, the outlet must be properly installed and grounded. All electrical connections must be made in accordance with local codes and ordinances.



Extension Cords

We do not recommend the use of extension cords on 220V equipment. Instead, arrange the placement of your equipment and the installed wiring to eliminate the need for extension cords.

If you find it absolutely necessary to use an extension cord at 220V with your machine:

- Make sure the cord is rated for Standard Service (grade S) or better.
- The extension cord must also contain a ground wire and plug prong.
- Use at least a 12 gauge cord and make sure the cord is less than 50 feet long.



Inventory

After all the parts have been removed from the two boxes, you should have the following items:

Wood Crate: (Figure 2)	Qty
A. Jointer Assembly w/Fence	1
B. Cutterhead Guard Assembly	1
C. Dust Port	1
D. Handles	2
E. Handwheels.....	2
F. Fence Tilt Lever	1
G. V-Belts.....	2
H. Knife Setting Jig Hardware Bag	
—Knife Setting Jig Rod	1
—Knife Setting Jig Foot	2
—E-Clip	4
I. Tools and Fastener Hardware Bag	
—Special Mounting Bolts	3
—Lock Washers $\frac{3}{8}$ "	3
—Phillips Head Screws $\frac{1}{4}$ "-20 x $\frac{3}{8}$ "	4
—Flat Washers $\frac{1}{4}$ "-20	4
—Hex Wrench 3mm	1
—Hex Wrench 4mm	1
—Hex Wrench 5mm	1
—Open End Wrench 8/10mm	1
—Open End Wrench 12/14mm	1
J. Push Blocks.....	2

Cardboard Carton: (Figure 3)	Qty
K. Stand Assembly w/Motor and Door	1
L. Pedestal Arm w/Magnetic Switch.....	1
M. Pedestal and Switch Hardware Bag	
—Phillips Head Screw M5-.8 x 20	2
—Flat Washer 5MM	2
—Hex Nut M5-.8	2
—Strain Relief	1
—Hex Bolt M8-1.25 x 20	4
—Flat Washer 8MM	4

In the event that any nonproprietary parts are missing (e.g. a nut or a washer), we would be glad to replace them, or for the sake of expediency, replacements can be obtained at your local hardware store.

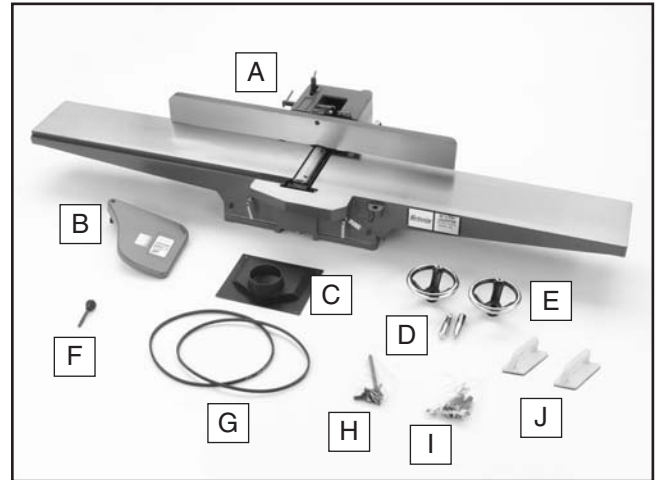

Figure 2. Box 1 inventory contents.



Figure 3. Box 2 inventory contents.

Clean Up

The unpainted surfaces are coated with a waxy oil to protect them from corrosion during shipment. Remove this protective coating with a solvent cleaner or citrus-based degreaser such as Grizzly's G7895 Degreaser. To clean thoroughly, some parts may need to be removed. **For optimum performance from your machine, make sure you clean all moving parts or sliding contact surfaces that are coated.** Avoid chlorine-based solvents, such as acetone or brake parts cleaner, as they may damage painted surfaces should they come in contact.

To access the sliding surfaces, remove the fence lock nut (**Figure 4**) and handle, and remove the fence from the jointer unit.

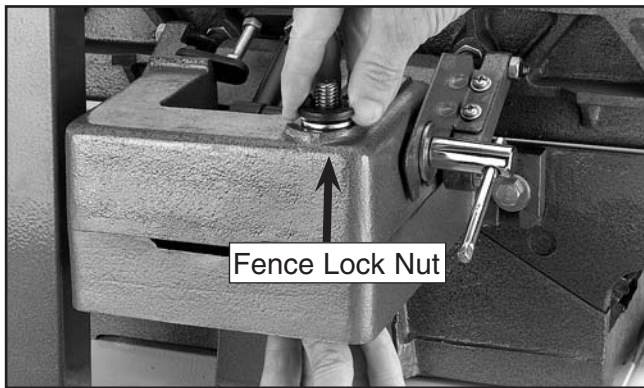

Figure 4. Removing the fence lock nut so the sliding surfaces can be cleaned.

Once the sliding surfaces of the fence are clean, reassemble the fence to the jointer with the lock handle on the top and the fence lock nut below the fence support assembly.

	<p>! WARNING Gasoline and petroleum products have low flash points and could cause an explosion or fire if used to clean machinery. DO NOT use gasoline or petroleum products to clean the machinery.</p>
--	---



Site Considerations

Floor Load

The Model G0586 weighs 418 lbs. and has a base footprint of 17½" x 23". Most floors are suitable for your machine. Some residential floors may require additional reinforcement to support both the machine and operator.

Working Clearances

Consider the jointer dimensions and size of material to be processed through each machine, and space for auxiliary stands, work tables or other machinery when establishing a location for your jointer. See **Figure 5** for the Model G0586 overhead dimensions.

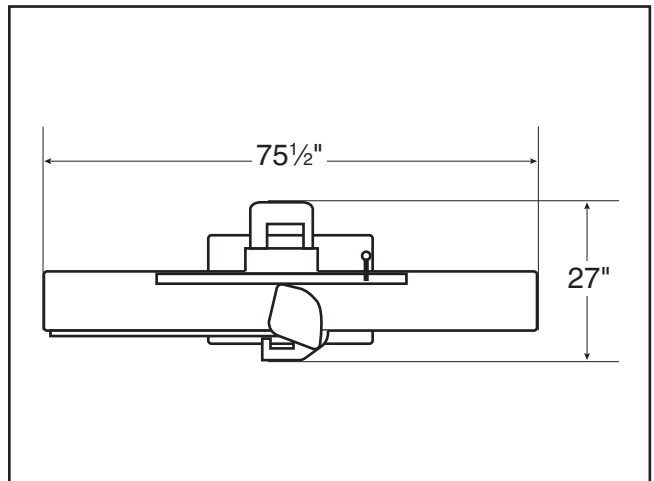

Figure 5. Model G0586 overhead dimensions.

	<p>! CAUTION Unsupervised children and visitors inside your shop could cause serious personal injury to themselves. Lock all entrances to the shop when you are away and DO NOT allow unsupervised children or visitors in your shop at any time!</p>
--	---



Mounting Jointer

Components and Hardware Needed:	Qty
Jointer.....	1
Jointer Stand	1
Special Mounting Bolts.....	3
Lock Washers 3/8"	3

Tools Needed:	Qty
Wrench or Socket 14mm	1
Extra Person for Lifting Help	1

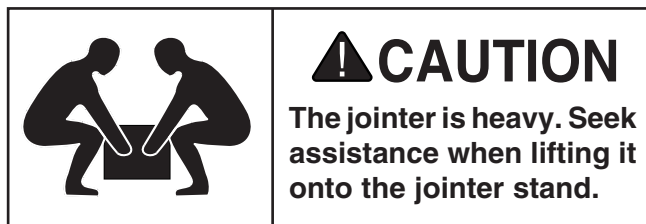

To mount the jointer to the stand:

1. With the help of an assistant, lift the jointer onto the stand.
2. Align the three bolt holes on the jointer with the three holes on the stand (**Figure 6**).

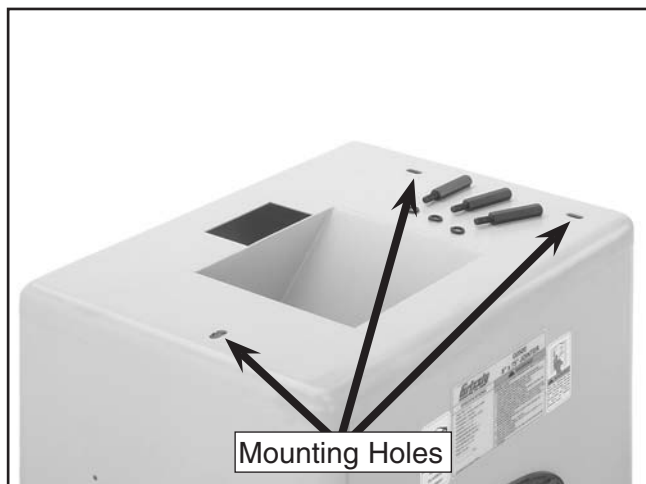

Figure 6. Mounting holes.

3. Using a 14mm wrench, secure the jointer to the stand with the special mounting bolts and lock washers.



V-Belt

Components and Hardware Needed:	Qty
V-Belts	2

Tools Needed:	Qty
Wrench or Socket 12mm	1

To install the V-belt:

1. Remove the back access panel from the jointer stand, and the belt guard from the jointer.
2. Using a 12mm wrench, loosen the motor mount bolts. Note—DO NOT completely remove the motor mount bolts.
3. Slide the motor upward far enough to allow the V-belts to be placed around the cutterhead pulley and the motor pulley.
4. Carefully allow the motor to slide downward, tensioning the V-belts with the weight of the motor.
5. Visually check the alignment of the two pulleys (**Figure 7**) to make sure that they are aligned and that the V-belts are straight up and down between the pulleys.

Note—We find it is easiest to see the alignment by laying on the ground and looking up from underneath the motor.

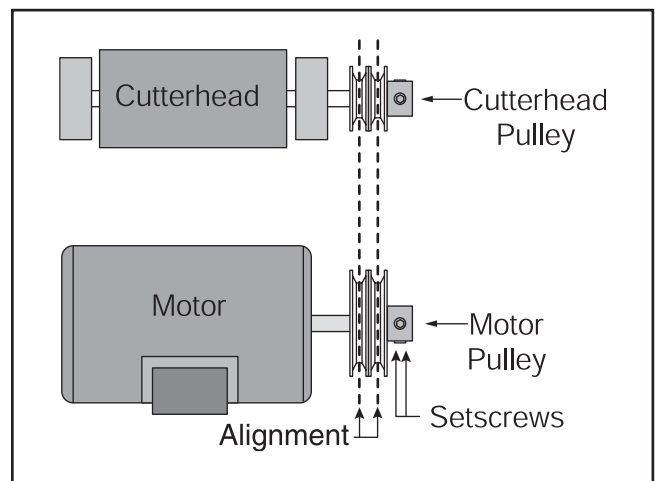

Figure 7. The pulleys should be aligned so the V-belts are straight up and down.

— If the pulleys are aligned, tighten the motor mounts loosened in **Step 1** and go to **Step 8**.

— If the pulleys are NOT aligned, perform **Steps 6 & 7**.

6. Remove the V-belts, loosen the set screws on the end of the motor pulley, and align the motor pulley with the cutterhead pulley.
7. Tighten the set screws, replace the V-belts, and repeat **Step 5**.
8. Replace the access cover on the stand and the V-belt cover on the jointer, as shown in **Figure 8**.

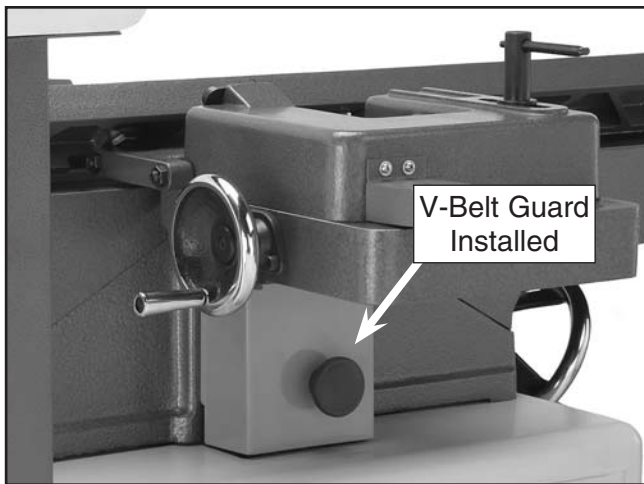

Figure 8. V-belt guard installed.



Fence Tilt Lever

Components and Hardware Needed:	Qty
Fence Tilt Lever.....	1

Install the tilt lever where shown in **Figure 9**.

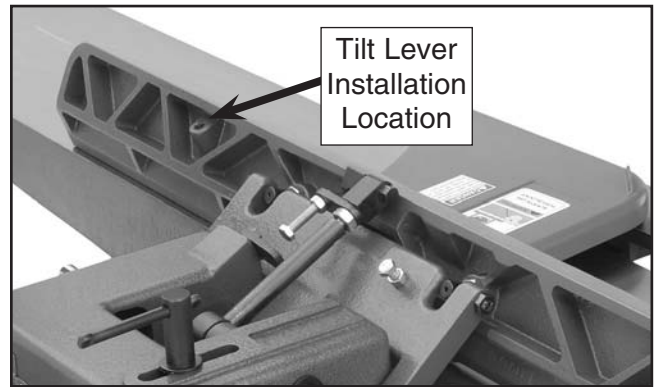

Figure 9. Tilt lever installation location.



Dust Port

Components and Hardware Needed:	Qty
Dust Port	1
Phillips Head Screws 1/4"-20 x 3/8".....	4
Flat Washers 1/4"	4

Tools Needed:	Qty
Phillips Head Screwdriver	1

Install the dust port as shown in **Figure 10**.



Figure 10. Correctly installed dust port.



Cutterhead Guard

CAUTION

The cutterhead guard is a critical safety feature on this machine. A torsion spring is mounted on the cutterhead guard shaft to help it return to its proper position over the cutterhead after a cutting operation. This torsion spring must have spring pressure during guard installation to work properly.

To install the cutterhead guard:

1. Wind the tang on the torsion spring back a half turn, and slide the guard shaft into the casting so the spring tang points to the right and rests against the casting, as shown in **Figure 11**.

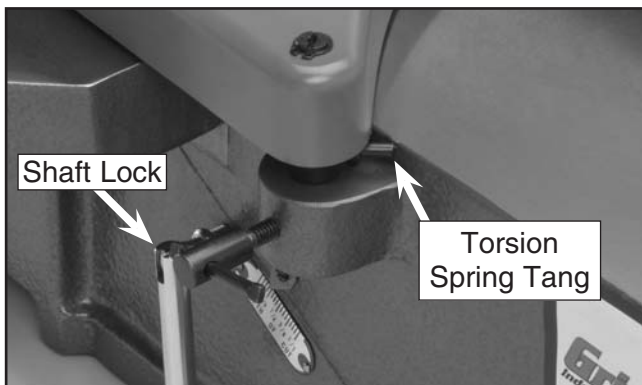

Figure 11. Guard mounted with spring tang in the correct position for proper return tension.

2. Test the guard by pulling it back and letting go.
 - The guard should snap back over the cutterhead without dragging across the table. If it does, tighten the shaft lock.
 - If the guard drags across the table, raise it until it won't drag, then tighten the shaft lock.
 - If the guard does not snap back, remove it and repeat **Steps 1 & 2**, increasing the spring tension as needed.



Switch Components

Components and Hardware Needed:	Qty
Pedestal Arm w/Magnetic Switch.....	1
Hex Bolts M8-1.25 x 20.....	4
Flat Washers 8mm	4
Phillips Head Screw M5-.8 x 20	2
Flat Washer 5mm.....	2
Hex Nut M5-.8	2
Strain Relief.....	1

Tools Needed:	Qty
Wrench or Socket 12mm	1

To install the switch components:

1. **Make sure you have NOT connected your jointer to the power source at this time.**
2. Remove the white cover from the magnetic switch via the two plastic screws on the front.
3. Attach the magnetic switch to the jointer stand, as shown in **Figure 12**, using the Phillips head screws, flat washers, and hex nuts.

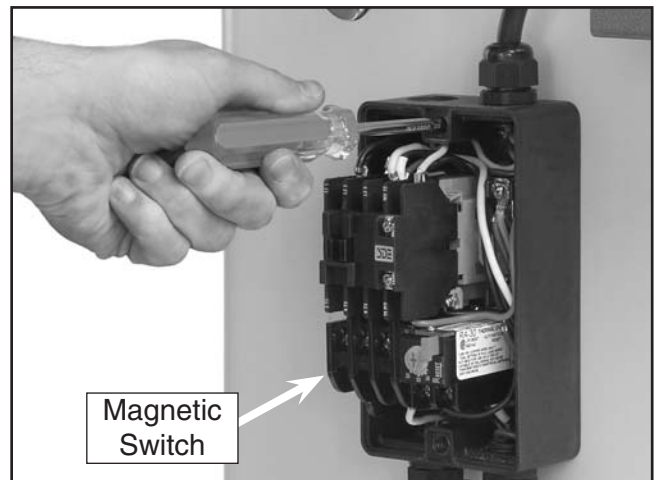

Figure 12. Attaching magnetic switch to stand.

4. Re-attach the cover to the magnetic switch. Note—**DO NOT** overtighten the plastic screws or they will break!

Continued on next page 

- Secure the pedestal arm to the jointer stand with the hex bolts and flat washers, as shown in **Figure 13**.

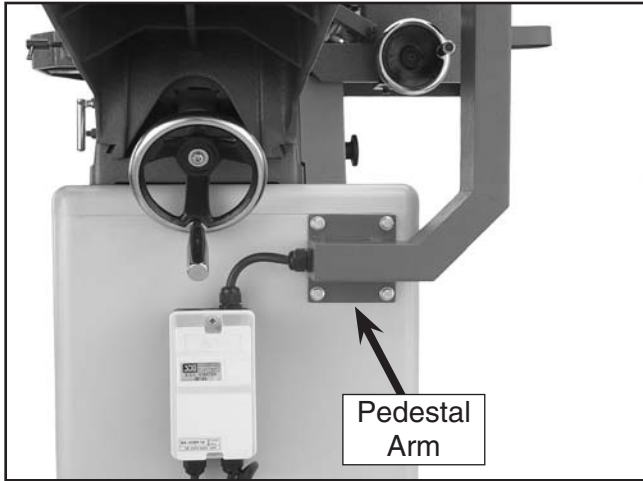

Figure 13. Correctly installed switch components.

- Place the strain relief around the shortest cord coming out of the switch (motor cord), so the larger side of the strain relief is toward the switch.
- Thread the motor cord through the access hole in the stand.
- Make sure there is a little slack in the wire between the switch and the strain relief, then snap fit the strain relief into the opening as shown in **Figure 14**.

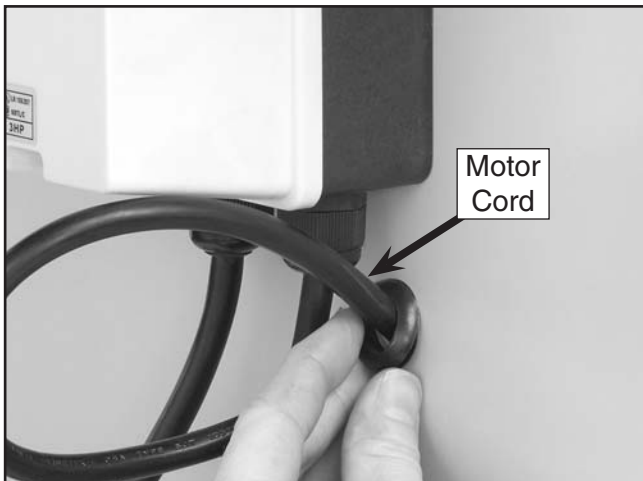

Figure 14. Installing strain relief.

- Remove the cover from the motor junction box.
- Make the motor connections in accordance with **Figure 15**.

Note—Wiring diagrams that may be on the inside of the junction box supersede the diagram below.

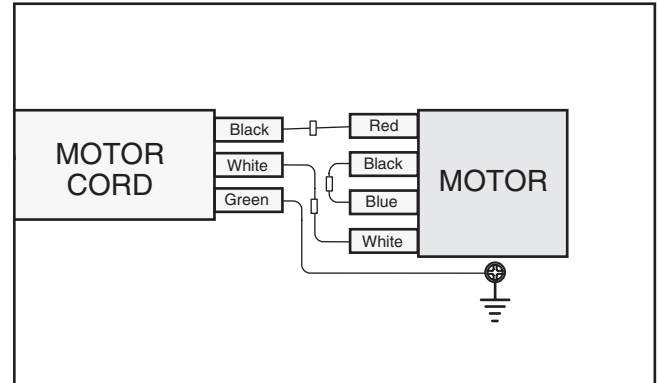

Figure 15. 220V motor wiring.

- Replace the motor junction box cover and stand cover.



Handwheels

Components and Hardware Needed:	Qty
Handwheels.....	2
Handwheel Handles	2

Tools Needed:	Qty
Phillips Head Screwdriver	1
Wrench 14mm	1

To install the handwheels:

1. Remove the two screws and flat washers already mounted to the handwheel shafts.
2. Secure the handwheels to the shafts with the hardware removed in **Step 1**.
3. Secure the handwheel handles to the handwheels, as shown in **Figure 16**.



Figure 16. Securing the handwheel handle.



Knife Setting Jig

Components and Hardware Needed:	Qty
Knife Setting Jig Rod.....	1
Knife Setting Jig Foot	2
E-Clip.....	4

Assemble the knife setting jig as shown in **Figure 17**.



Figure 17. Knife setting jig assembly.



Test Run

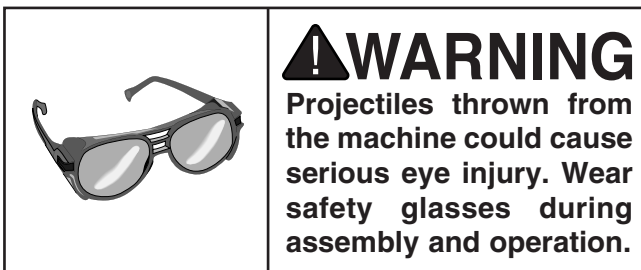
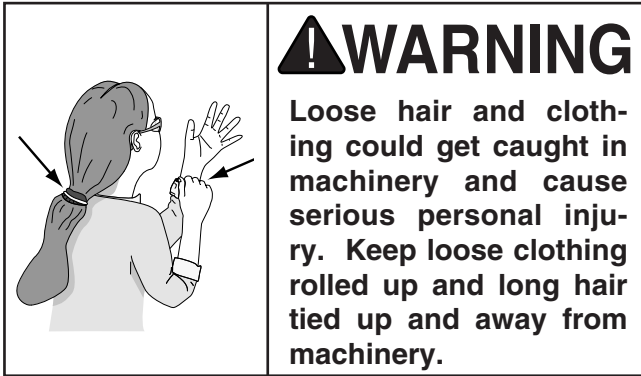

Starting the machine:

1. Read the entire instruction manual.
2. Make sure the cutterhead guard is installed and correctly adjusted (**Page 15**).
3. Make sure all tools and foreign objects have been removed from the machine.
4. Review Section 2: Circuit Requirements (**Page 9**) and connect your machine to the power source.
5. Press the START button to turn the machine ON.

—The jointer should run smoothly with little or no vibration.

—Immediately stop the jointer if you suspect any problems, and refer to **Page 36** to troubleshoot/fix any problems before starting the jointer again.

—If you need any help with your jointer call our Tech Support at (570) 546-9663.



Recommended Adjustments

For your convenience, the adjustments listed below have been performed at the factory and no further setup is required to operate your machine.

However, because of the many variables involved with shipping, we recommend that you at least verify the following adjustments to ensure the best possible results from your new machine.

Step-by-step instructions for these adjustments can be found in Section 7: Service.

Factory adjustments that should be verified:

1. Knife Settings (**Page 29**).
2. Outfeed Table Height (**Page 31**).
3. Depth Scale Calibration (**Page 31**).
4. Fence Stop Accuracy (**Page 32**).



SECTION 4: OPERATIONS

Operation Safety

⚠️ WARNING

Damage to your eyes, lungs, and ears could result from using this machine without proper protective gear. Always wear safety glasses, a respirator, and hearing protection when operating this machine.

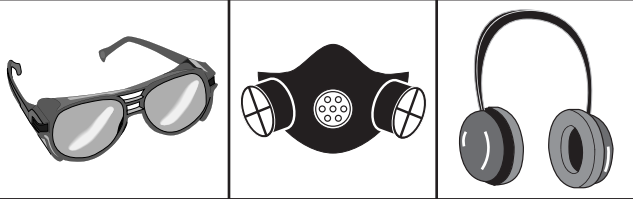

⚠️ WARNING

Loose hair and clothing could get caught in machinery and cause serious personal injury. Keep loose clothing and long hair away from moving machinery.



NOTICE

If you have never used this type of machine or equipment before, WE STRONGLY RECOMMEND that you read books, trade magazines, or get formal training before beginning any projects. Regardless of the content in this section, Grizzly Industrial will not be held liable for accidents caused by lack of training.



Stock Inspection and Requirements

Here are some rules to follow when choosing and jointing stock:

- **DO NOT joint or surface plane stock that contains knots.** Injury to the operator or damage to the workpiece can occur if the knots become dislodged during the cutting operation.
- **DO NOT joint or surface plane against the grain direction.** Cutting against the grain increases the likelihood of stock kickback, as well as tear-out on the workpiece.
- **Jointing and surface planing with the grain produces a better finish and is safer for the operator.** Cutting with the grain is described as feeding the stock on the jointer so the grain points down and toward you as viewed on the edge of the stock (Figure 18).

Note—If the grain changes direction along the edge of the board, decrease the cutting depth and make additional passes.

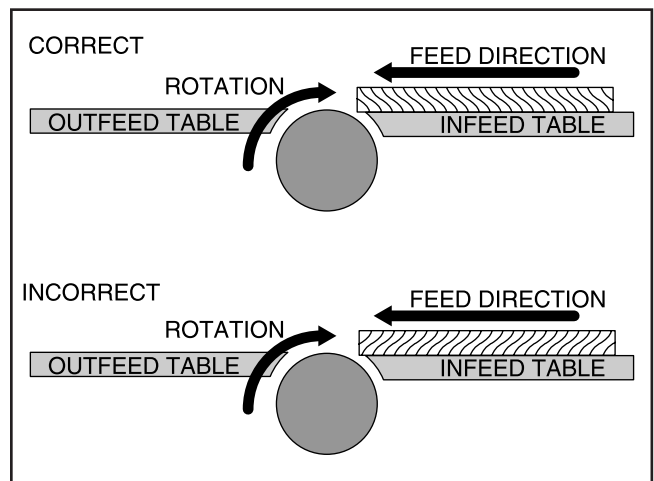

Figure 18. Correct and incorrect grain alignment to cutterhead.

- **Remove foreign objects from the stock.** Make sure that any stock you process with the jointer is clean and free of any dirt, nails, staples, tiny rocks or any other foreign objects that may damage the jointer blades.
- **Only process natural wood fiber through your jointer.** Never joint MDF, particle board, plywood, laminates or other synthetically made materials.
- **Make sure all stock is sufficiently dried before jointing.** Wood with a moisture content over 20% will cause unnecessary wear on the knives and poor cutting results.
- **Make sure your workpiece exceeds the minimum dimension requirements (Figures 19 & 20) before edge jointing or surface planing, or it may break or kick back during the operation!**

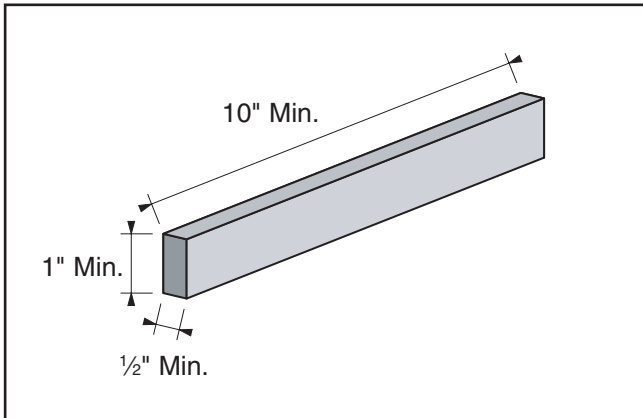

Figure 19. Minimum dimensions for edge jointing.

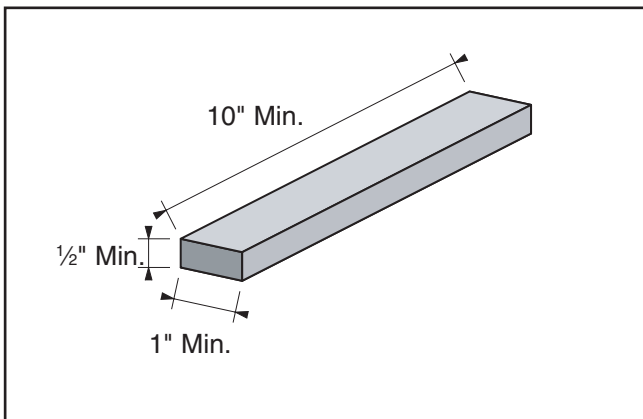
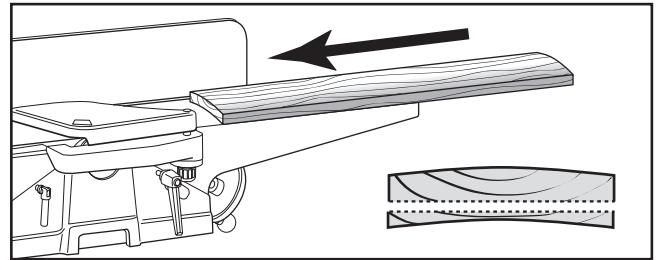

Figure 20. Minimum dimensions for surface planing.

Squaring Stock

Squaring stock involves four steps performed in the order below:

1. Surface Plane On The Jointer—The concave face of the workpiece is surface planed flat with the jointer.



2. Surface Plane On a Thickness Planer—The opposite face of the workpiece is surface planed flat with a thickness planer.

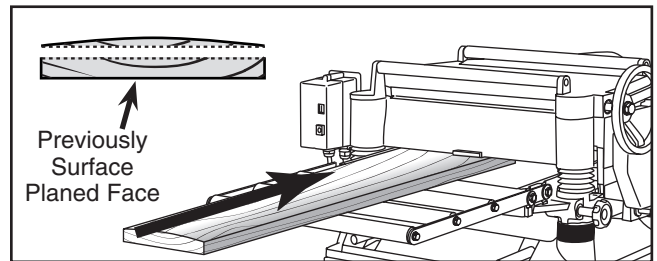

3. Edge Joint On The Jointer—The concave edge of the workpiece is jointed flat with the jointer.

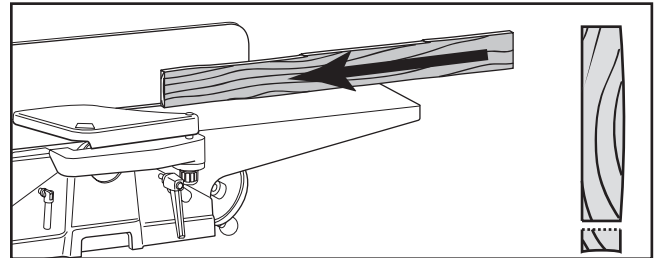

4. Rip Cut On A Table Saw—The jointed edge of the workpiece is placed against a table saw fence and the opposite edge cut off.

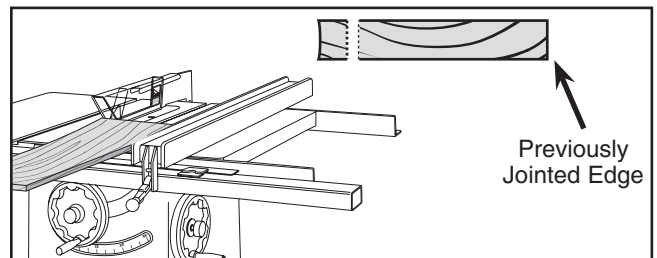

Surface Planing

The purpose of surface planing on the jointer is to make one flat face on a piece of stock (see **Figures 21 & 22**) to prepare it for surface planing on a thickness planer.

NOTICE

If you are not experienced with a jointer, set the depth of cut to 0", and practice feeding the workpiece across the tables as described. This procedure will better prepare you for the actual operation.

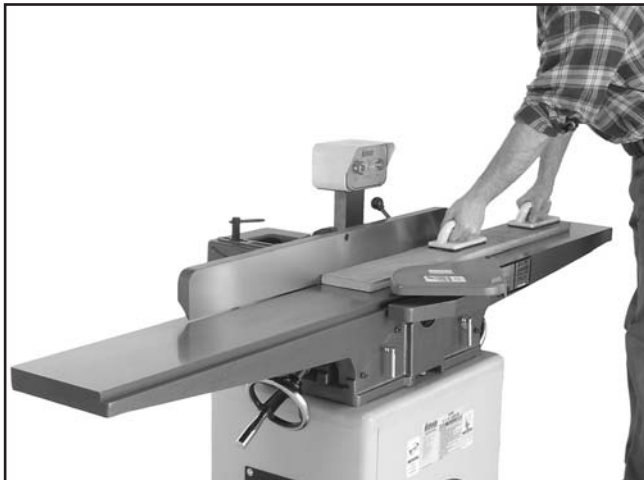

Figure 21. Typical surface planing operation.

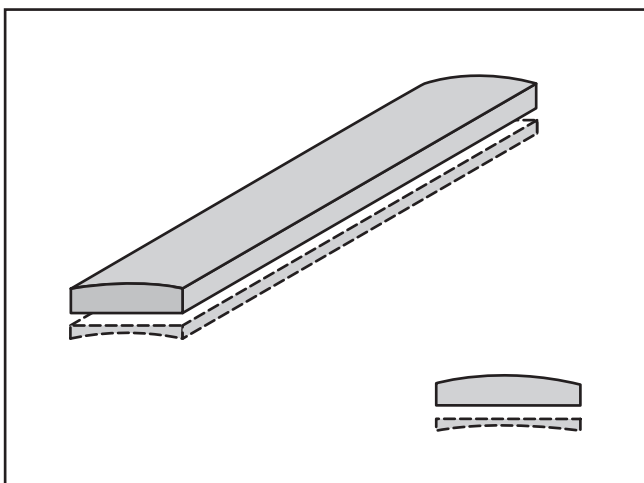

Figure 22. Illustration of surface planing results.

To surface plane on the jointer:

1. Read and understand Section 1: Safety, beginning on **Page 6**.
2. Make sure your stock has been inspected for dangerous conditions as described in the Stock Inspection & Requirements instructions, beginning on **Page 19**.
3. Set the cutting depth for your operation. (We suggest $\frac{1}{32}$ " for surface planing, using a more shallow depth for hard wood species or for wide stock.)
4. Make sure your fence is set to 90°
5. If your workpiece is cupped (warped), place it so the concave side is face down on the surface of the infeed table.
6. Start the jointer.

! WARNING

Failure to use push blocks when surface planing may result in cutterhead contact, which will cause serious personal injury. Always use push blocks to protect your hands when surface planing on the jointer.

7. With a push block in each hand, press the workpiece against the table and fence with firm pressure, and feed the workpiece over the cutterhead.

Note—If your leading hand (with push block) gets within 4" of the cutterhead, lift it up and over the cutterhead, and place the push block on the portion of the workpiece that is on the outfeed table. Now, focus your pressure on the outfeed end of the workpiece while feeding, and repeat the same action with your trailing hand when it gets within 4" of the cutterhead. To keep your hands safe, DO NOT let them get closer than 4" from the cutterhead when it is moving!

8. Repeat **Step 7** until the entire surface is flat.



Edge Jointing

The purpose of edge jointing is to produce a finished, flat-edged surface (see **Figures 23 & 24**) that is suitable for joinery or finishing. It is also a necessary step when squaring rough or warped stock.

NOTICE

If you are not experienced with a jointer, set the depth of cut to 0", and practice feeding the workpiece across the tables as described below. This procedure will better prepare you for the actual operation.



Figure 23. Typical edge jointing operation.

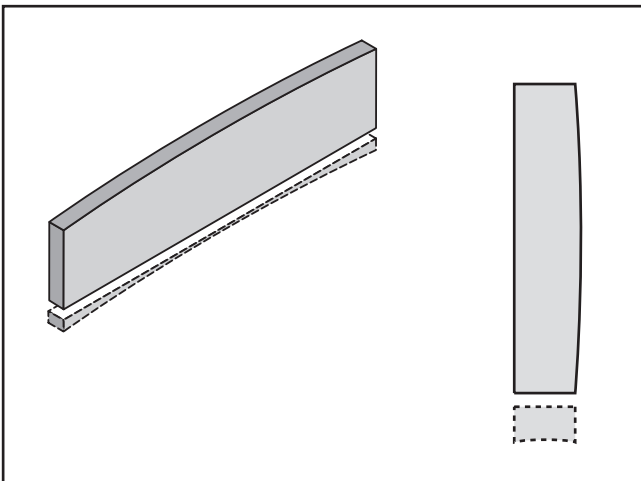

Figure 24. Illustration of edge jointing results.

To edge joint on the jointer:

1. Read and understand Section 1: Safety, beginning on **Page 6**.
2. Make sure your stock has been inspected for dangerous conditions as described in the Stock Inspection instructions, beginning on **Page 19**.
3. Set the cutting depth for your operation. (We suggest between $\frac{1}{16}$ " and $\frac{1}{8}$ " for edge jointing, using a more shallow depth for hard wood species or for wide stock.)
4. Make sure the fence is set to 90° .
5. If your workpiece is cupped (warped), place it so the concave side is face down on the surface of the infeed table.
6. Start the jointer.
7. Press the workpiece against the table and fence with firm pressure. Use your trailing hand to guide the workpiece through the cut, and feed the workpiece over the cutterhead.

Note—If your leading hand gets within 4" of the cutterhead, lift it up and over the cutterhead, and place it on the portion of the workpiece that is over the outfeed table. Now, focus your pressure on the outfeed end of the workpiece while feeding, and repeat the same action with your trailing hand when it gets within 4" of the cutterhead. To keep your hands safe, **DO NOT** let them get closer than 4" from the cutterhead when it is moving!

8. Repeat **Step 7** until the entire edge is flat.



Bevel Cutting

The purpose of bevel cutting is to cut a specific angle into the edge of a workpiece (see **Figures 25 & 26**).

The Model G0586 has preset fence stops at 45° inward, 90°, and 45° outward (135°). If your situation requires a different angle, the preset fence stops can be easily adjusted for your needs.

NOTICE

If you are not experienced with a jointer, set the depth of cut to 0", and practice feeding the workpiece across the tables as described below. This procedure will better prepare you for the actual operation.



Figure 25. Typical bevel cutting operation.

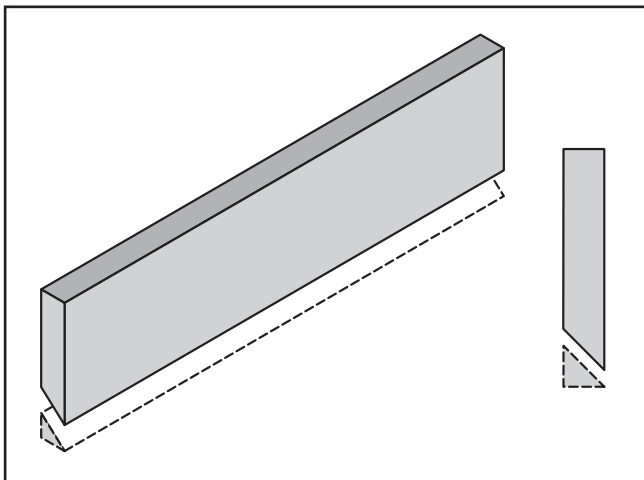

Figure 26. Illustration of bevel cutting results.

To bevel cut on the jointer:

1. Read and understand Section 1: Safety, beginning on **Page 6**.
2. Make sure your stock has been inspected for dangerous conditions as described in the Stock Inspection instructions, beginning on **Page 19**.
3. Set the cutting depth for your operation. (We suggest between $\frac{1}{16}$ " and $\frac{1}{8}$ " for bevel cutting, using a more shallow depth for hard wood species or for wide stock.)
4. Make sure your fence is set to the angle of your desired cut.
5. If your workpiece is cupped (warped), place it so the concave side is face down on the surface of the infeed table.
6. Start the jointer.
7. With a push block in your leading hand, press the workpiece against the table and fence with firm pressure, and feed the workpiece over the cutterhead.

Note—If your leading hand gets within 4" of the cutterhead, lift it up and over the cutterhead, and place the push block on the portion of the workpiece that is on the outfeed table. Now, focus your pressure on the outfeed end of the workpiece while feeding, and repeat the same action with your trailing hand when it gets within 4" of the cutterhead. To keep your hands safe, DO NOT let them get closer than 4" from the cutterhead when it is moving!

8. Repeat **Step 7** until the angled cut is satisfactory to your needs.



Rabbet Cutting

The purpose of rabbet cutting is to remove a section of the workpiece edge (see **Figures 27 & 28**). When combined with another rabbet cut edge, the rabbet joints create a simple, yet strong method of joining stock.

NOTICE

If you are not experienced with a jointer, set the depth of cut to 0", and practice feeding the workpiece across the tables as described below. This procedure will better prepare you for the actual operation.

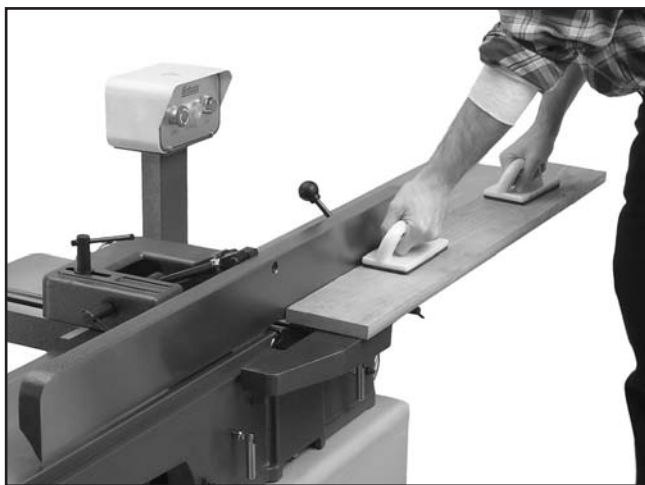

Figure 27. Typical rabbet cutting operation.

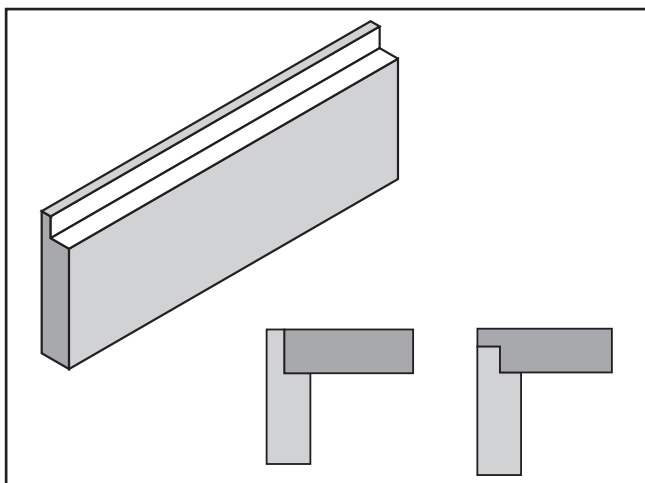

Figure 28. Illustration of rabbet cutting effects and a few sample joints.

To rabbet cut on the jointer:

1. Read and understand Section 1: Safety, beginning on **Page 6**.
2. Make sure your stock has been inspected for dangerous conditions as described in the Stock Inspection instructions, beginning on **Page 19**.
3. Set the cutting depth for your operation. (We suggest between $\frac{1}{16}$ " and $\frac{1}{8}$ " for rabbet cutting, using a more shallow depth for hard wood species or for wide stock.)
4. Remove the cutterhead guard.
5. Make sure your fence is moved forward, so the amount of infeed/outfeed table exposed is the same as the size of your rabbet. Also, make sure your fence is set to 90° .
6. Start the jointer.
7. With a push block in each hand, press the workpiece against the table and fence with firm pressure, and feed the workpiece over the cutterhead.

Note—If your leading hand gets within 4" of the cutterhead, lift it up and over the cutterhead, and place the push block on the portion of the workpiece that is on the outfeed table. Now, focus your pressure on the outfeed end of the workpiece while feeding, and repeat the same action with your trailing hand when it gets within 4" of the cutterhead. To keep your hands safe, **DO NOT** let them get closer than 4" from the cutterhead when it is moving!

8. Repeat **Step 6** until the your rabbet is cut to depth.

!WARNING

When the cutterhead guard is removed, attempting any other cut besides a rabbet directly exposes the operator to the moving cutterhead. Always replace the cutterhead guard after rabbet cutting!



SECTION 5: ACCESSORIES

G7314—Heavy-Duty SHOP FOX® Mobile Base

Make your machine mobile with this popular patented mobile base. The unique outrigger type supports increase stability and lower machine height. This heavy duty mobile base is rated for up to a 600 lb. capacity.



Figure 29. G7314 SHOP FOX® Mobile Base.

G3639—Power Twist® V-Belt - 3/8" x 48"

Smooth running with less vibration and noise than solid belts. The Power Twist® V-belts can be customized in minutes to any size—just add or remove sections to fit your needs. Size: 3/8" x 48"; replaces all "M" sized V-belts. Requires two Power Twist® V-belts to replace the stock V-belts on your Model G0586.

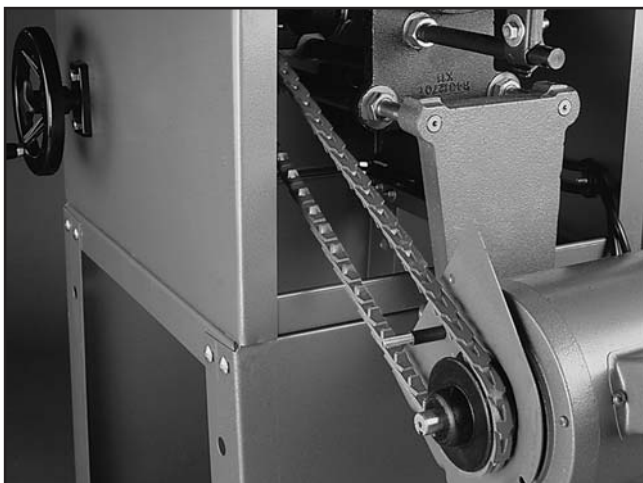

Figure 30. G3639 Power Twist® V-Belt.

G1753—Jointer Pal® Magnetic Knife Jig (For HSS & Cobalt Knives)

G1756—Jointer Pal® Magnetic Knife Jig (For Carbide Knives)

This patented magnetic knife-setting system lets you set jointer knives in perfect alignment every time! It also allows you to shift nicked knives to get a perfect cut to an accuracy of + or - 0.001".

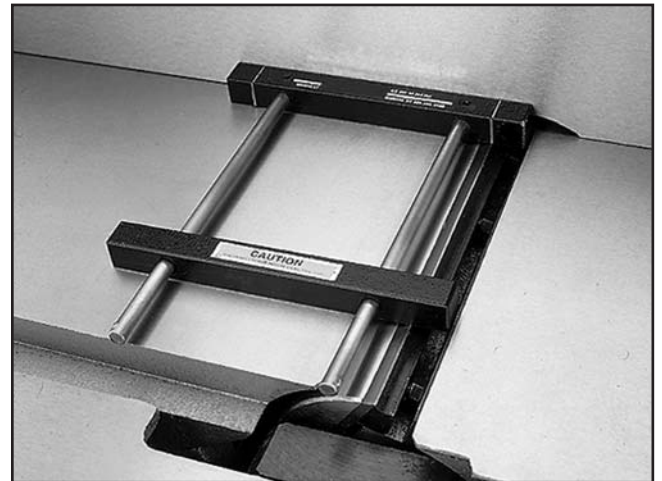

Figure 31. G1753 Jointer Pal® Knife Jig.

G3631—Jointer/Planer Knife Hone

Add a razor hone to your planer and jointer knives with this hand-held sharpening device. This handy tool sharpens flat and beveled surfaces quickly and easily. Great for touch-ups.



Figure 32. G3631 Jointer/Planer Knife Hone.

Call 1-800-523-4777 To Order

G9256—6" Dial Caliper
G9257—8" Dial Caliper
G9258—12" Dial Caliper

Required for jointing, planing, or sanding to critical tolerances. These traditional dial calipers are accurate to 0.001" and can measure outside surfaces, inside surfaces, and heights/depths. Features stainless steel, shock resistant construction and a dust proof display. An absolute treat for the perfectionist!

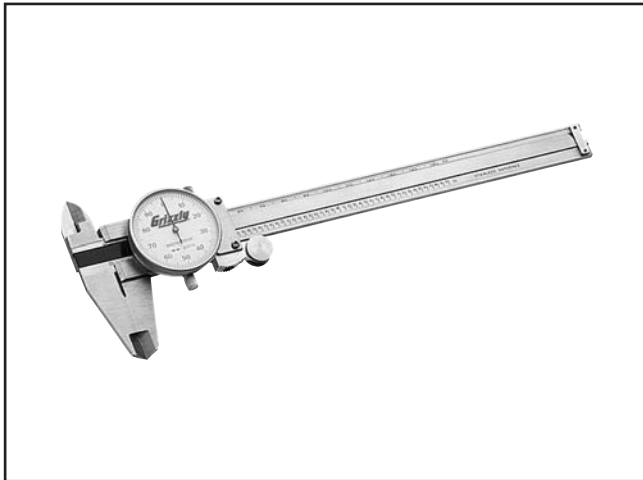

Figure 33. Grizzly® Dial Calipers.

H5142—Dispoz-A-Blade® System
(Includes 4 Holders & Knife Inserts)
H5143—Dispoz-A-Blade® Knife Inserts
(Set of 4)

Install a Dispoz-A-Blade® Knife system in your new jointer and save up to 70% on knife replacements for the life of your jointer. Each knife insert is double-edged, so you get two knives in one, and is indexed so that all knife inserts can be installed at the same height in just minutes. Yes, that means you can throw away the knife jig!

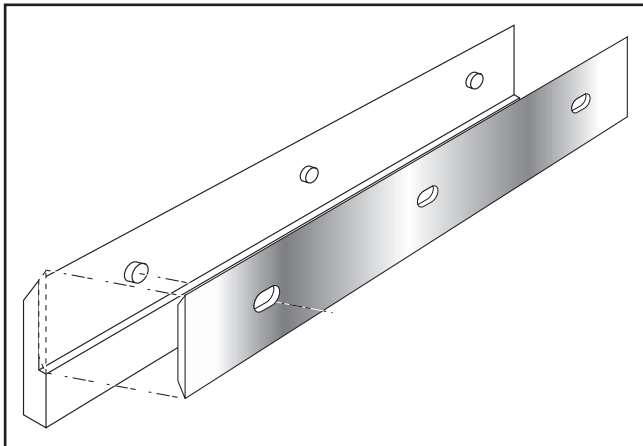

Figure 34. Dispoz-A-Blade® Holder and Knife.

H4982—8" HSS Replacement Jointer Knives
(Set of 4)

H1411—PowerHands™ Safety Stick

This safety push stick features interchangeable traction treads; one for flat stock, and one for pressing against table and fence. It also has a spring loaded push-pin for full workpiece contact. Made in the USA.



Figure 35. H1411 PowerHands™ Safety Stick.

G9643—8" Precision Straightedge
G9644—12" Precision Straightedge
H2675—16" Precision Straightedge

Ideal for aligning your outfeed bed to the cutterhead and calibrating your depth scale. These grade 00 heavy-duty stainless steel straightedges are manufactured to DIN874 standards for professional results in set-up and inspection work.



Figure 36. Straightedges.

Call 1-800-523-4777 To Order

- G7984—Face Shield
- H1298—Dust Sealed Safety Glasses
- H1300—UV Blocking, Clear Safety Glasses
- H2347—Uvex® Spitfire Safety Glasses
- H0736—Shop Fox® Safety Glasses

Safety Glasses are essential to every shop. If you already have a pair, buy extras for visitors or employees. You can't be too careful when it comes to shop safety!



Figure 37. Our most popular safety glasses.

- H6175—Power Respirator
- H6892—3M Pre-Filter, 10-Pack
- H6893—Filter Cartridge, 10-Pack, P100

Say goodbye to foggy safety glasses and labored breathing, this battery powered respirator supplies a constant breeze of fresh air all day long. Comes with its own plastic case for clean, sealed storage. Finally, a respirator you can look forward to wearing—at an affordable price!



Figure 38. H6175 Power Respirator.

- H2499—Small Half-Mask Respirator
- H3631—Medium Half-Mask Respirator
- H3632—Large Half-Mask Respirator
- H3635—Disposable Cartridge Filter Pair P100

Wood dust is a known carcinogen and has been linked to nasal cancer and severe respiratory illnesses. If you work around dust everyday, a half-mask respirator can be a lifesaver. Also compatible with safety glasses!



Figure 39. Half-mask respirator and disposable cartridge filters.

- G5562—SLIPIT® 1 Qt. Gel
- G5563—SLIPIT® 12 oz Spray
- G2871—Boeshield® T-9 12 oz Spray
- G2870—Boeshield® T-9 4 oz Spray
- H3788—G96® Gun Treatment 12 oz Spray
- H3789—G96® Gun Treatment 4.5 oz Spray

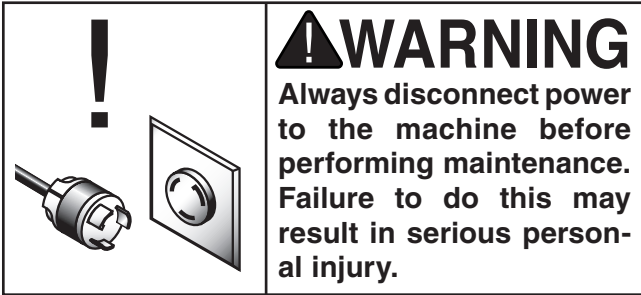

Figure 40. Recommended products for protecting unpainted cast iron/steel part on machinery.

Call 1-800-523-4777 To Order



SECTION 6: MAINTENANCE



Schedule

For optimum performance from your machine, follow this maintenance schedule and refer to any specific instructions given in this section.

Daily:

- Vacuum all dust on and around the machine.
- Wipe down tables and all other unpainted cast iron with a metal protectant.

Monthly Check:

- V-belt tension, damage, or wear.
- Clean/vacuum dust buildup from inside cabinet and off of motor.



V-Belts

To ensure optimum power transmission from the motor to the blade, the V-belts must be in good condition (free from cracks, fraying and wear) and properly aligned and tensioned (refer to the instructions on **Page 13**).



Cleaning

Cleaning the Model G0586 is relatively easy. Vacuum excess wood chips and sawdust, and wipe off the remaining dust with a dry cloth. If any resin has built up, use a resin dissolving cleaner to remove it.

Protect the unpainted cast iron surfaces on the table by wiping the table clean after every use—this ensures moisture from wood dust does not remain on bare metal surfaces.

Keep tables rust-free with regular applications of products like , G96® Gun Treatment, SLIPIT®, or Boeshield® T-9.



Lubrication

Since all bearings are sealed and permanently lubricated, simply leave them alone until they need to be replaced. **DO NOT** lubricate them.

Table ways and the fence assembly should not be lubricated. If the tables appear to be stuck, disassemble and clean any foreign materials from the ways. Re-assemble and reset the gibs.



SECTION 7: SERVICE

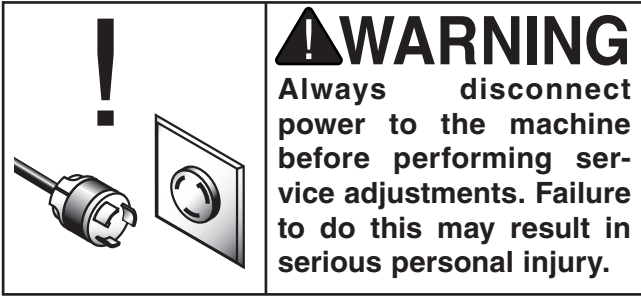

About Service

This section is designed to help the operator with adjustments that were made at the factory and that might also need to be made during the life of the machine.

This section is provided for your convenience—it is not a substitute for the Grizzly Service Department.

If any adjustments arise that are not described in this manual or you are unsure of how to perform the procedures in this section, then feel free to call Technical Support at (570) 546-9663.



Inspecting Knives

The height of the knives can be easily and quickly inspected with the knife setting jig. This inspection will ensure that the knives are set in the cutterhead as they should be. Usually this is done before calibrating the outside table or when troubleshooting.

To inspect the knives:

1. **Disconnect the jointer from the power source!**
2. Remove the cutterhead guard or block it out of the way.

3. Lower the infeed table to the ½" scale mark.
4. Place the knife jig on the cutterhead, directly over a knife, as shown in **Figure 41**.

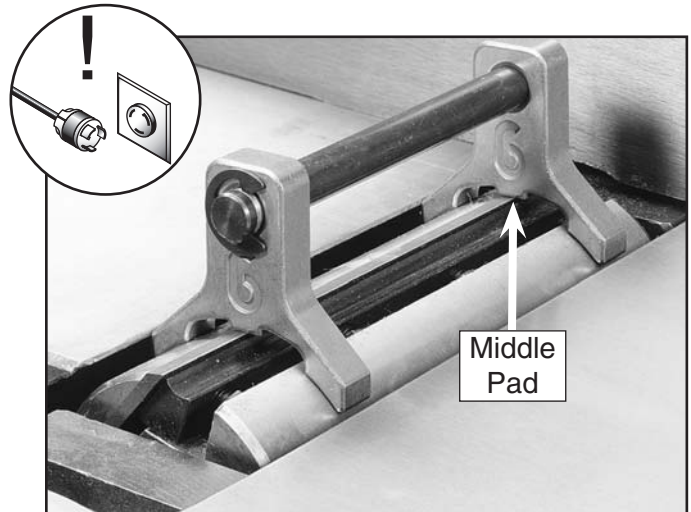

Figure 41. Jig positioned over cutterhead knife.

5. Carefully inspect how the jig touches the cutterhead and the knife.
 - If both outside legs of the jig sit firmly on the cutterhead and the middle pad just touches the knife, then that knife is set correctly. (Repeat this inspection with the other knives.)
 - If the jig does not sit firmly on the cutterhead and touch the knife edge as described, then reset that knife. (Repeat this inspection with the other knives before resetting.)



Setting Knives

Setting the knives correctly is crucial to the proper operation of the jointer and is very important in keeping the knives sharp. If one knife is higher than the others, it will do the majority of the work, and thus, dull much faster than the others.

The knife jig included with the jointer is designed to set the knives at the correct height.

The Grizzly 8" Jointers come with both jack screws and springs to provide you with two options for cutterhead adjustments (see **Figure 42**). Note—Only one of these options is needed to set the knives—see **Step 5*** for clarification.

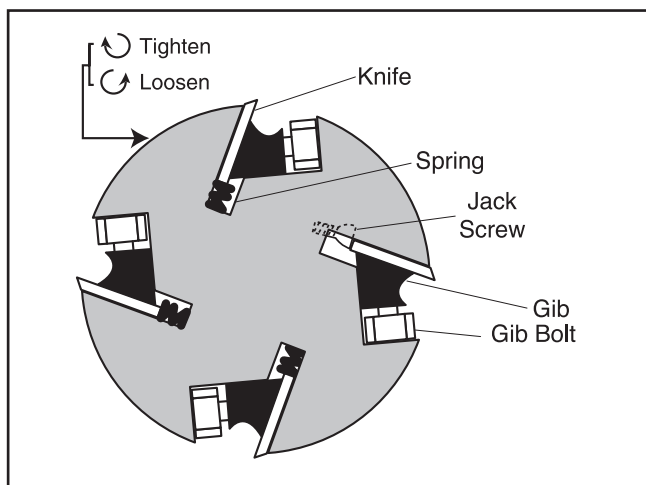

Figure 42. Cutterhead profile diagram.

To set the knives:

1. **Disconnect the jointer from the power source!**
2. Remove the cutterhead guard from the table and lower the infeed and outfeed tables as far as they go. This will give you unrestricted access to the cutterhead.
3. Remove the belt guard to expose the cutterhead pulley.
4. Rotate the cutterhead pulley to give you good access to one of the cutterhead knives.
5. Loosen the cutterhead gib bolts, starting in the middle, and alternating back and forth until all of the gib bolts are loose, but not falling out.

*Note—If this is the first time you are setting the knives, remove the gib and knife from the cutterhead. Decide which adjustment option you are going to use between the jack screws and the springs. If you decide to use the jack screws, remove the springs from the cutterhead. If you decide to use the springs, you can just thread the jack screws completely into the cutterhead so they will not get lost. Replace the gib and knife.

6. Position the knife gauge over the knife as shown in **Figure 41** and loosen the gib bolts until the knife is completely loose.
7. **Jack Screws**—Using a 3mm hex wrench, find the jack screws through the access holes in the cutterhead (**Figure 43**) and rotate the jack screws to raise or lower the knife. When the knife is set correctly, it will barely touch the middle pad of the knife setting jig. Snug the gib bolts tight enough to just hold the knife in place. Repeat **Steps 5-7** with the rest of the knives.

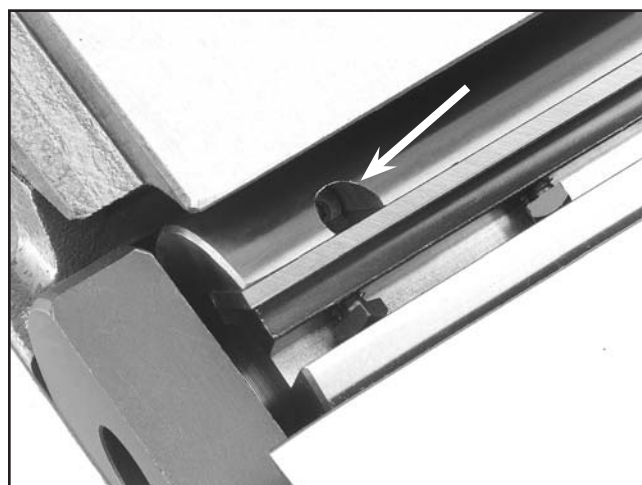

Figure 43. Jack screw access hole.

Springs—Push the knife down with the jig so that the knife edge is touching the middle pad of the jig. Hold the jig down and tighten the gib bolts just tight enough to hold the knife in place. Repeat **Steps 5-7** with the rest of the knives.

8. Rotate the cutterhead to the first knife you started with. Slightly tighten all the gib bolts, starting at the ends and working your way to the middle by alternating left and right. Repeat this step on the rest of the knives.
9. Repeat **Step 8**.
10. Repeat **Step 8**, but final tighten each gib bolt.
11. Adjust the outfeed table to match the new knife heights.



Setting Outfeed Table Height

The outfeed table must be level with the knives when they are at top-dead-center.

To set the outfeed table height:

1. Place a straightedge on the outfeed table so it extends over the cutterhead.
2. Rotate the cutterhead pulley until one of the knives is at top-dead-center (TDC), as illustrated in **Figure 44**.

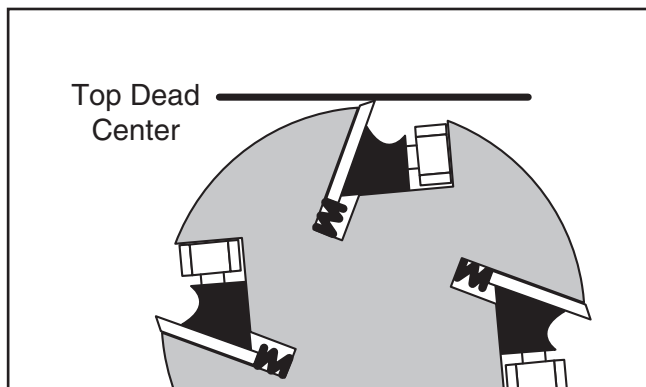

Figure 44. Cutterhead knife at top-dead-center.

3. Raise or lower the outfeed table until the knife just touches the straightedge (**Figure 45**).

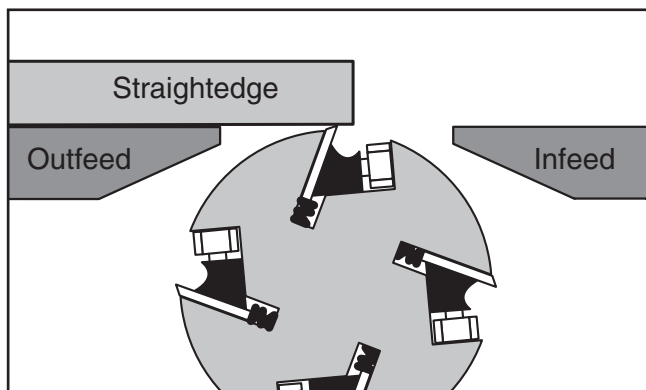

Figure 45. Using a straightedge to align outfeed table height with knife at TDC.

4. Lock the outfeed table.



Calibrating Depth Scale

The depth scale on the infeed table can be calibrated or "zeroed" if it is not correct.

To calibrate the depth scale:

1. Set the outfeed table height as described in the Outfeed Table Height sub-section.
2. Place a straightedge across the infeed and outfeed tables.
3. Adjust the infeed table until it is level with the outfeed table, as illustrated in **Figure 46**.

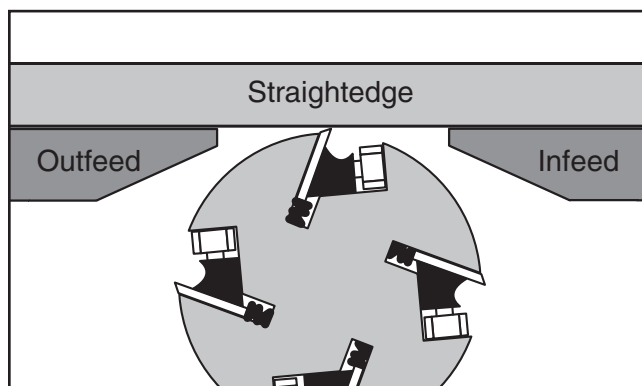

Figure 46. Infeed table adjusted even with outfeed table and knife at TDC.

4. Using a screwdriver, adjust the scale pointer exactly to "0" (**Figure 47**).

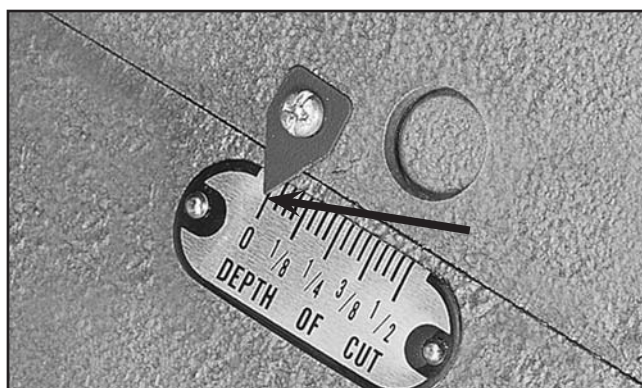

Figure 47. Depth-of-cut pointer adjusted to "0" position.



Setting Fence Stops

The fence stops are adjustable nuts and bolts that simplify the task of adjusting the fence to 45° inward, 90°, and 45° outward (135°).

To set the 45° inward fence stop:

1. Using a 45° square, adjust the fence to the 45° inward position, as shown in **Figure 48**.



Figure 48. Adjusting fence 45° inward.

2. Loosen the jam nut shown in **Figure 49**.

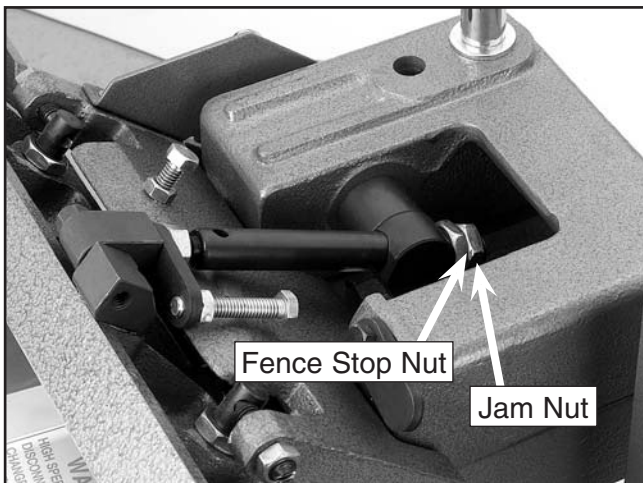

Figure 49. 45° inward fence stop jam nut.

3. Adjust the 45° inward fence stop nut until it makes contact with the back of the fence bracket.
4. Retighten the jam nut loosened in **Step 2**.

To set the 90° fence stop:

1. Using a 90° square, adjust the fence to the 90° position, as shown in **Figure 50**.



Figure 50. Adjusting fence to 90°.

2. Flip the 90° swing stop into the position shown in **Figure 51**.

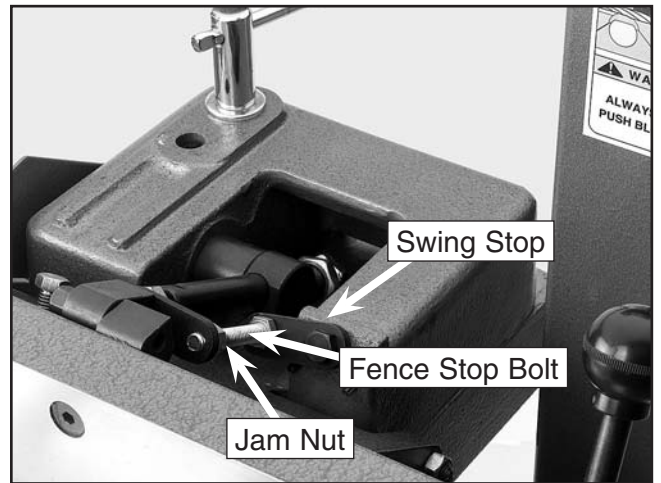

Figure 51. 90° swing stop engaged.

3. Loosen the jam nut on the 90° fence stop bolt (**Figure 51**).
4. Adjust the 90° fence stop bolt until it makes contact with the 90° swing stop.
5. Retighten the jam nut loosened in **Step 3**.

Continued on next page →

To set the 45° outward fence stop:

1. Using a sliding bevel adjusted to 135°, adjust the fence to the 135° (45° outward) position.



Figure 52. Adjusting fence 45° outward.

2. Loosen the jam nut on the 45° outward fence stop bolt (**Figure 53**).

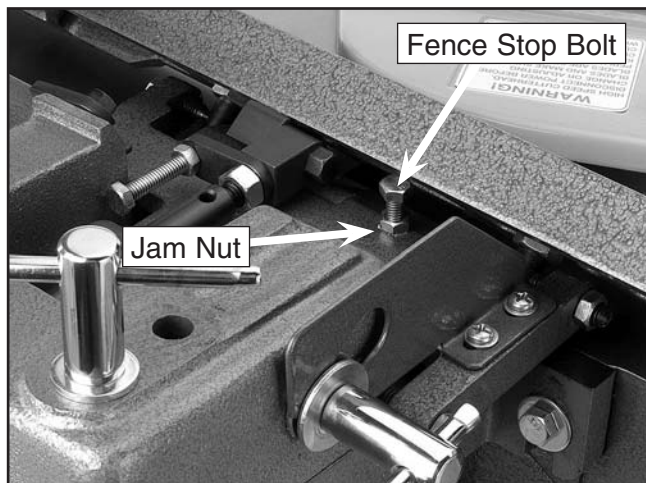

Figure 53. 45° outward fence stop jam nut.

3. Adjust the 45° outward fence stop bolt until it makes contact with the back of the fence.
4. Retighten the jam nut loosened in **Step 2**.



Adjusting Gibs

The function of the table gibs is to eliminate excessive play in the table movement. The gibs also control how easy it will be to move the tables up and down.

To adjust the table gibs:

1. Using a 12mm wrench, loosen the two outfeed table gib nuts on the side of the jointer base (**Figure 54**).

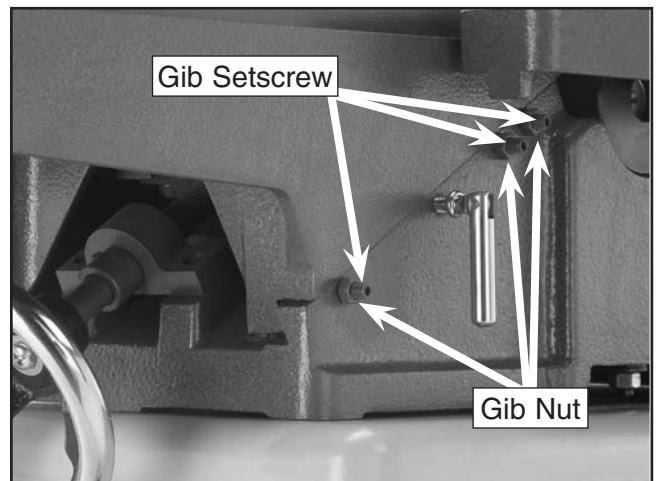

Figure 54. Outfeed table gib controls.

2. Using a 4mm hex wrench, evenly tighten both gib setscrews a small amount, then check the table by moving it up and down. Adjust the setscrews as needed until the friction of the table movement is balanced between minimal play and ease of movement.

Note—Tighter gibs reduce play but make it harder to adjust the tables.

3. Repeat **Steps 1-2** with the other table.
4. Set the outfeed table height as described in Outfeed Table Height on **Page 31**.



Wiring Diagram



MODEL G0586

⚠ DANGER
 Disconnect power before performing any electrical service. Electricity presents serious shock hazards that will result in severe personal injury and even death!

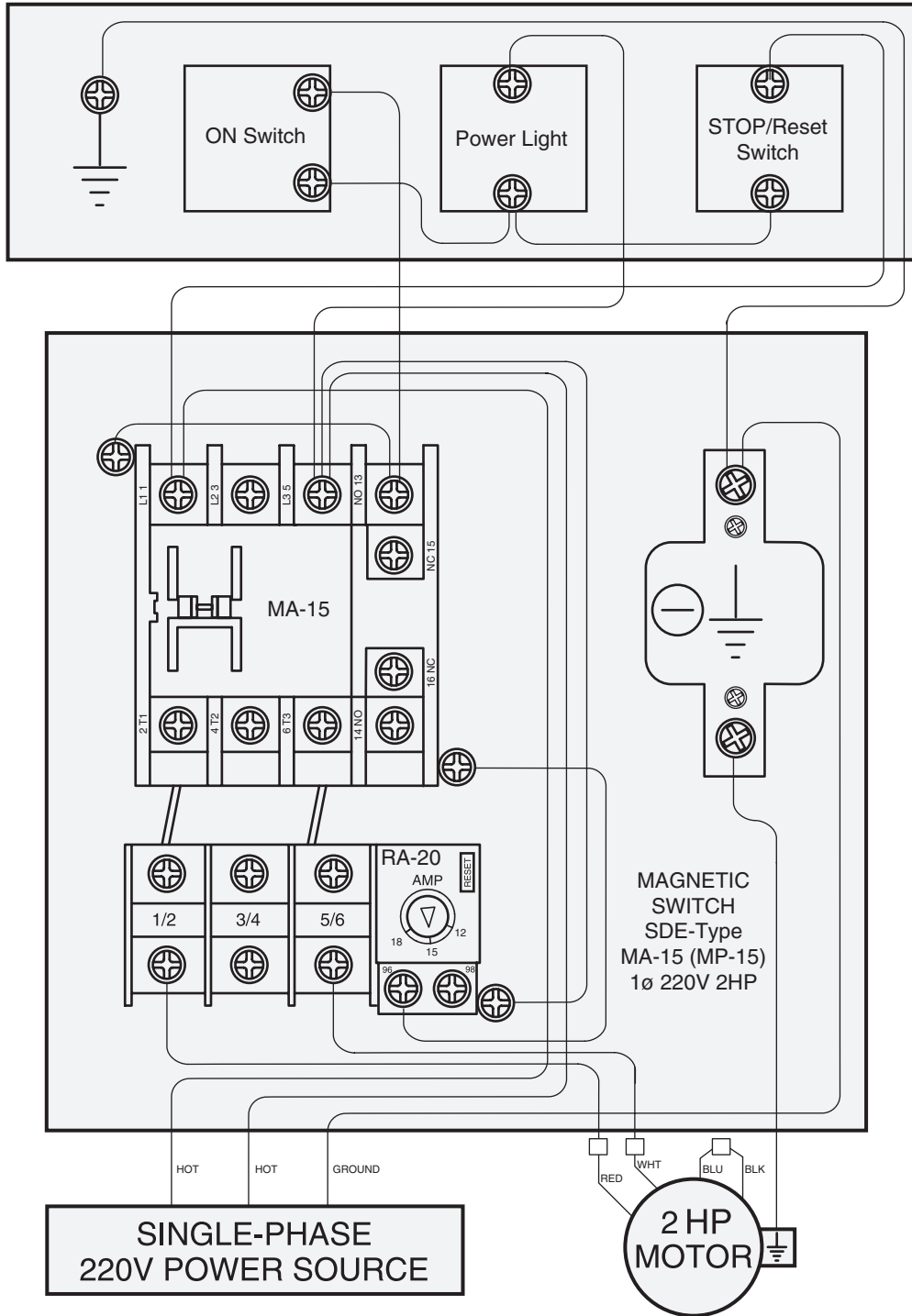
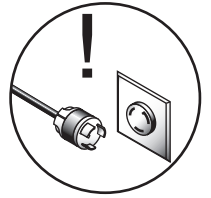

G0586 Electrical Components

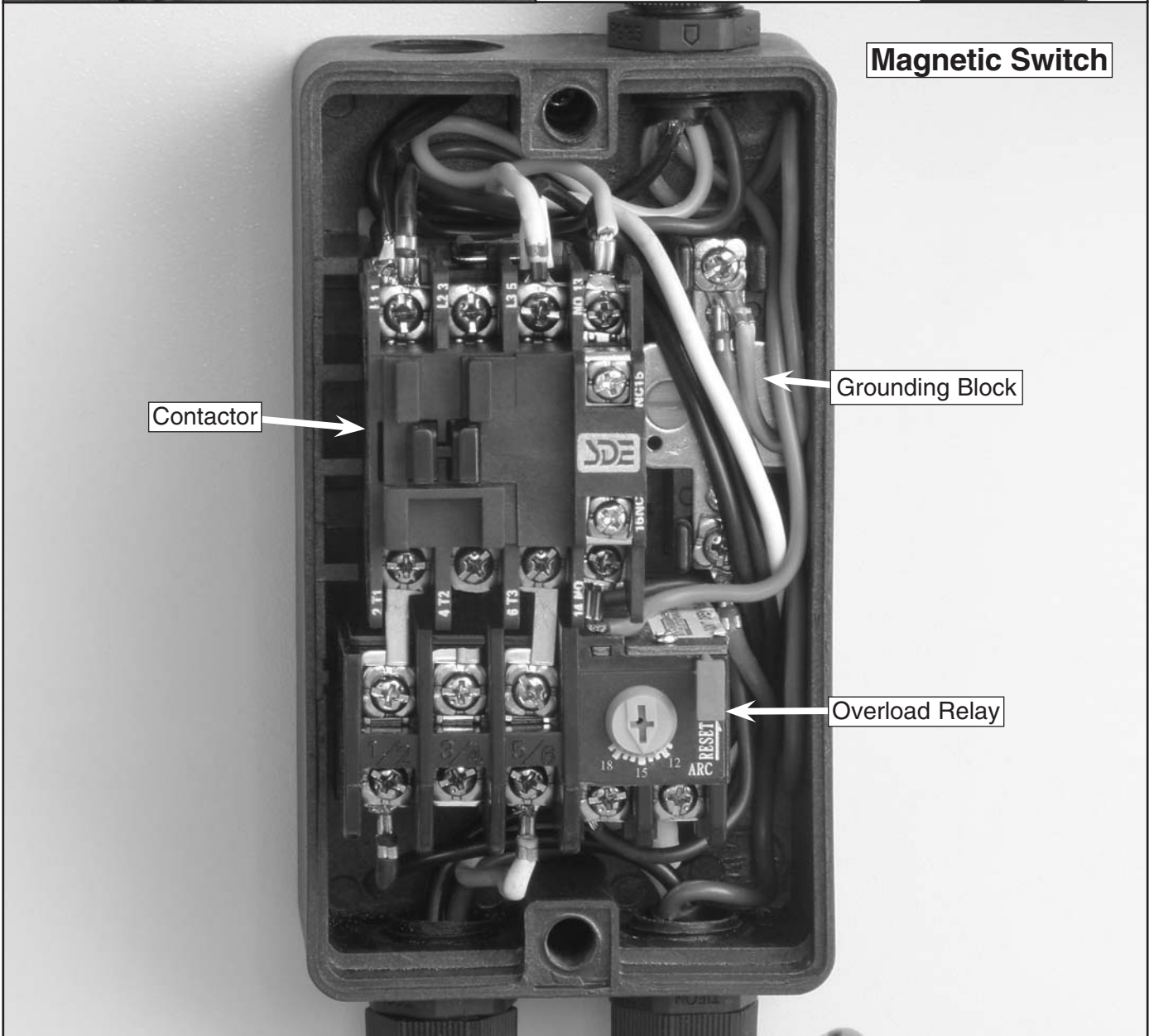
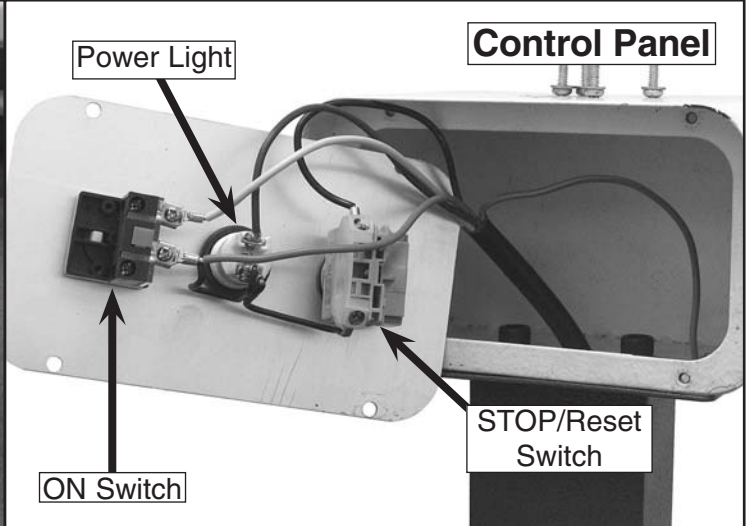
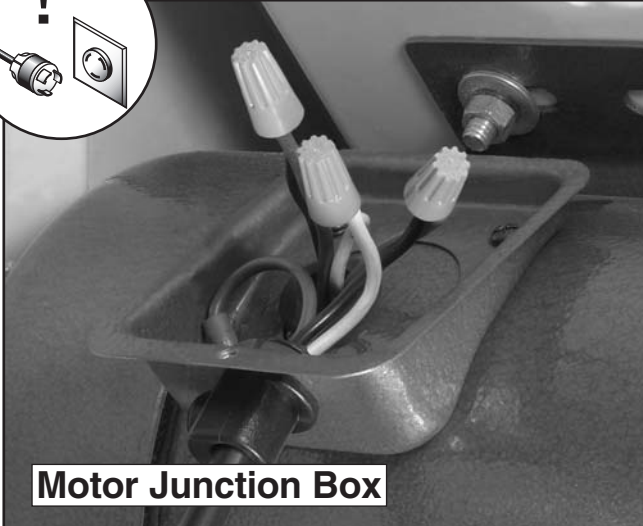
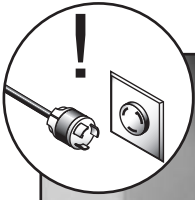

Troubleshooting Guide

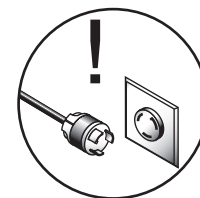

Motor & Machine Operation

Symptom	Possible Cause	Possible Solution
Motor will not start.	<ol style="list-style-type: none"> 1. Emergency stop button depressed. 2. Low voltage. 3. Open circuit in motor or loose connections. 	<ol style="list-style-type: none"> 1. Twist the emergency stop button to allow it to pop out. 2. Check power line for proper voltage. 3. Inspect all lead connections on motor for loose or open connections.
Fuses or circuit breakers blow.	<ol style="list-style-type: none"> 1. Short circuit in line cord or plug. 	<ol style="list-style-type: none"> 1. Repair or replace cord or plug for damaged insulation and shorted wires.
Motor fails to develop full power (output of motor decreases rapidly with decrease in voltage at motor terminals).	<ol style="list-style-type: none"> 1. Power supply circuit overloaded with lights, appliances, and other motors. 2. Undersized wires or circuits too long. 	<ol style="list-style-type: none"> 1. Reduce load on circuit. 2. Increase wire sizes or reduce length of the circuit.
Motor overheats.	<ol style="list-style-type: none"> 1. Motor overloaded during operation. 2. Air circulation through the motor restricted. 	<ol style="list-style-type: none"> 1. Reduce load on motor; take lighter cuts. 2. Clean out motor to provide normal air circulation.
Motor stalls or shuts off during a cut.	<ol style="list-style-type: none"> 1. Motor overloaded during operation. 2. Thermal overload protection tripped in magnetic switch. 3. Short circuit in motor or loose connections. 4. Circuit breaker tripped. 	<ol style="list-style-type: none"> 1. Reduce load on motor; take lighter cuts. 2. Press the "Reset" button on the thermal overload relay, located inside the magnetic switch. 3. Repair or replace connections on motor for loose or shorted terminals or worn insulation. 4. Install correct circuit breaker; reduce # of machines running on that circuit (circuit overload).
Blade slows when cutting or makes a squealing noise, especially on start-up.	<ol style="list-style-type: none"> 1. V-belt loose. 2. V-belt worn out. 	<ol style="list-style-type: none"> 1. Tighten V-belt (Page 13). 2. Replace V-belt (Page 13).
Loud repetitious noise coming from machine.	<ol style="list-style-type: none"> 1. Pulley setscrews or keys are missing or loose. 2. Motor fan is hitting the cover. 3. V-belts are damaged. 	<ol style="list-style-type: none"> 1. Inspect keys and setscrews. Replace or tighten if necessary. 2. Adjust fan cover mounting position, tighten fan, or shim fan cover. 3. Replace V-belts (Page 13).
Vibration when running or cutting.	<ol style="list-style-type: none"> 1. Loose or damaged blade. 2. Damaged V-belt. 3. Worn cutterhead bearings. 	<ol style="list-style-type: none"> 1. Tighten or replace blade. 2. Replace. 3. Check/replace cutterhead bearings.

Table

Symptom	Possible Cause	Possible Solution
Tables are hard to adjust	<ol style="list-style-type: none"> 1. Table lock is engaged or partially engaged. 2. Table gibs are too tight. 	<ol style="list-style-type: none"> 1. Completely loosen the table lock. 2. Re-adjust the table gibs (Page 33).
Excessive play in table movement.	<ol style="list-style-type: none"> 1. Table gibs are too loose. 	<ol style="list-style-type: none"> 1. Re-adjust the table gibs (Page 33).

Cutting

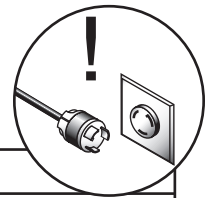

Symptom	Possible Cause	Possible Solution
Excessive snipe (gouge in the end of the board that is uneven with the rest of the cut).	<ol style="list-style-type: none"> 1. Outfeed table is set too low. 2. Operator pushing down on end of workpiece. 	<ol style="list-style-type: none"> 1. Align outfeed table with cutterhead knife at top dead center (Page 31). 2. Reduce/eliminate downward pressure on that end of workpiece.
Workpiece stops in the middle of the cut.	<ol style="list-style-type: none"> 1. Outfeed table is set too high. 	<ol style="list-style-type: none"> 1. Align outfeed table with cutterhead knife at top dead center (Page 31).
Chipping.	<ol style="list-style-type: none"> 1. Knots or conflicting grain direction in wood. 2. Nicked or chipped blades. 3. Feeding workpiece too fast. 4. Taking too deep of a cut. 	<ol style="list-style-type: none"> 1. Inspect workpiece for knots and grain (Page 19); only use clean stock. 2. Adjust one of the nicked knives sideways; replace knives (Page 29). 3. Slow down the feed rate. 4. Take a smaller depth of cut. (Always reduce cutting depth when surface planing or working with hard woods.)
Fuzzy Grain.	<ol style="list-style-type: none"> 1. Wood may have high moisture content or surface wetness. 2. Dull knives. 	<ol style="list-style-type: none"> 1. Check moisture content and allow to dry if moisture is too high. 2. Replace knives (Page 29).
Long lines or ridges that run along the length of the board	<ol style="list-style-type: none"> 1. Nicked or chipped knives. 	<ol style="list-style-type: none"> 1. Adjust one of the nicked knives sideways; replace knives (Page 29).
Uneven cutter marks, wavy surface, or chatter marks across the face of the board.	<ol style="list-style-type: none"> 1. Feeding workpiece too fast. 2. Knives not adjusted at even heights in the cutterhead. 	<ol style="list-style-type: none"> 1. Slow down the feed rate. 2. Adjust the knives so they are set up evenly in the cutterhead (Page 29).
Board edge is concave or convex after jointing.	<ol style="list-style-type: none"> 1. Board not held with even pressure on infeed and outfeed table during cut. 2. Board started too uneven. 3. Board has excessive bow or twist along its length. 4. Insufficient number of passes. 	<ol style="list-style-type: none"> 1. Hold board with even pressure as it moves over the cutterhead. 2. Take partial cuts to remove the extreme high spots before doing a full pass. 3. Surface plane one face so there is a good surface to position against the fence. 4. It may take 3 to 5 passes to achieve a perfect edge, depending on the starting condition of the board and the depth of cut.
Uneven cut or breakout when rabbeting.	<ol style="list-style-type: none"> 1. Uneven feed rate. 2. Depth of cut too deep. 3. Knives not adjusted evenly with each other in the cutterhead. 4. Nicked or chipped knives. 	<ol style="list-style-type: none"> 1. Feed the board evenly and smoothly during the cut. 2. Raise the infeed table to take a smaller depth of cut. Never exceed $\frac{1}{16}$" per pass when rabbeting. 3. Adjust the knives so they are set up evenly in the cutterhead (Page 29). 4. Adjust one of the nicked knives sideways; replace knives (Page 29).



Jointer Parts Breakdown

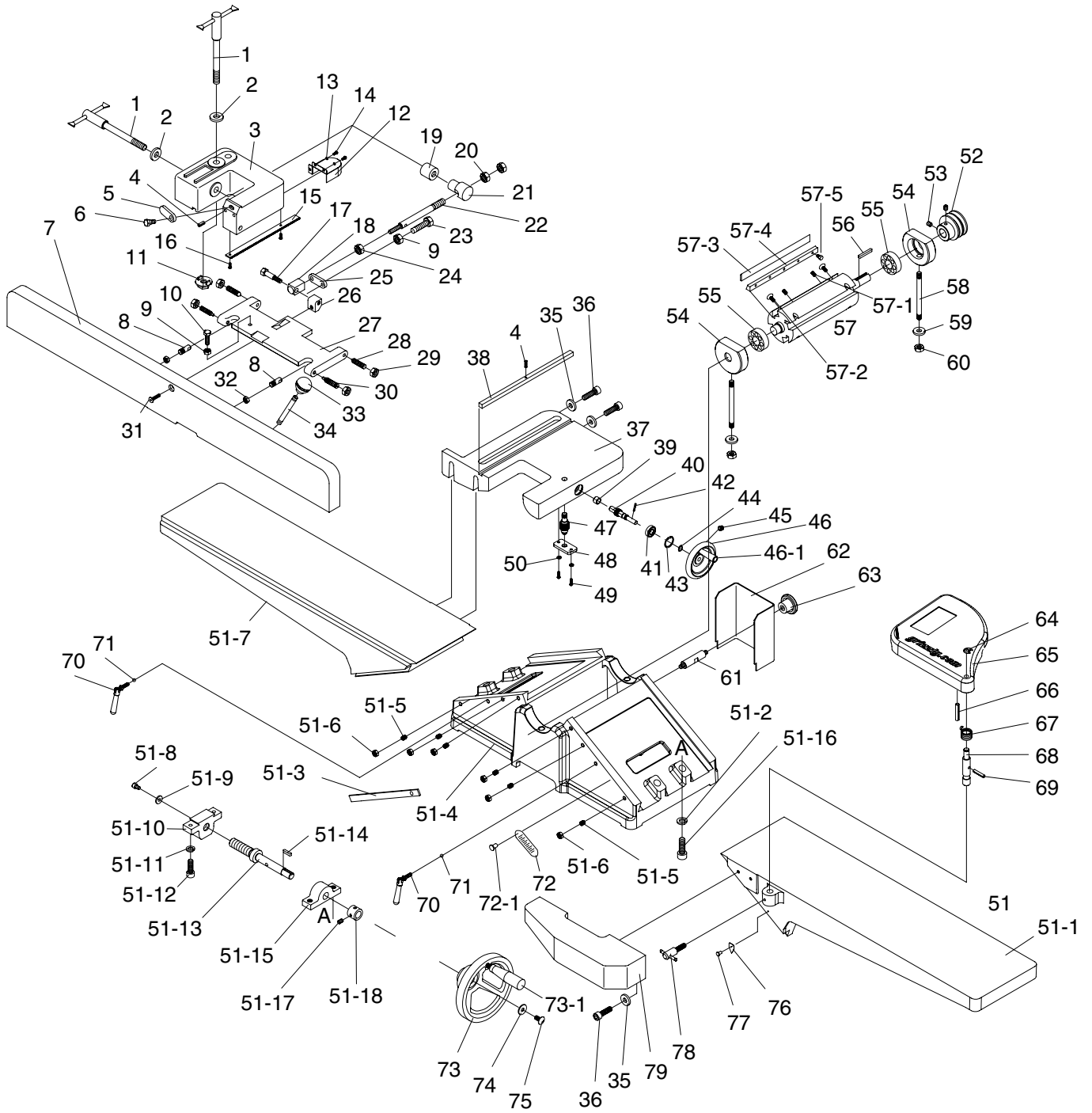

Jointer Parts List

REF	PART #	DESCRIPTION
1	P0586001	FENCE LOCK HANDLE
2	P0586002	FLAT WASHER 1/2
3	P0586003	FENCE BRACKET
4	P0586004	ROLL PIN 4 X 14
5	P0586005	STOP TAB
6	P0586006	SHOULDER BOLT 5/16-18 X 5/8
7	P0586007	FENCE
8	P0586008	SWIVEL SHAFT
9	PN02	HEX NUT 5/16-18
10	PB12	HEX BOLT 5/16-18 X 1-1/4
11	P0586011	FENCE LOCK NUT
12	P0586012	COVER
13	PW03	FLAT WASHER #10
14	PS06	PHLP HD SCR 10-24 X 3/8
15	P0586015	TOOTH GIB
16	PS01	PHLP HD SCR 10-24 X 1/2
17	P0586017	SHOULDER BOLT
18	P0586018	TAB BLOCK
19	P0586019	SPACING COLLAR
20	PN09	HEX NUT 5/8-18
21	P0586021	PIVOT NUT
22	P0586022	FENCE ADJUSTMENT STUD
23	PB22	HEX BOLT 5/16-18 X 1-3/4
24	PN19	HEX NUT 7/16-14
25	P0586025	STOP TAB
26	P0586026	FENCE BRACKET
27	P0586027	FENCE HINGE
28	P0586028	CONE SET SCREW 3/8-16 X 1-1/2
29	PN08	HEX NUT 3/8-16
30	P0586030	CONE SET SCREW 3/8-16 X 1-1/2
31	PB76	HEX BOLT 5/16-18 X 1-5/8
32	PN01	HEX NUT 1/2-20
33	P0586033	BALL KNOB 3/8-16
34	P0586034	HANDLE
35	PW02	FLAT WASHER 3/8
36	PSB26	CAP SCREW 3/8-16 X 1-1/2
37	P0586037	TABLE BRACKET
38	P0586038	FENCE KEY
39	P0586039	BUSHING
40	P0586040	WORM GEAR
41	P0586041	RADIAL BALL BEARING 6000
42	PRP42M	ROLL PIN 3 X 20
43	PR20M	INT RETAINING RING 28MM
44	PR03M	EXT RETAINING RING 12MM
45	PSS11	SET SCREW 1/4-20 X 1/4
46	P0586046	HANDWHEEL
46-1	P0586046-1	HANDLE
47	P0586047	WORM GEAR
48	P0586048	BRACKET
49	PS22	PHLP HD SCR 10-24 X 5/8
50	PLW03	LOCK WASHER #10
51	P0586051	TABLE ASSEMBLY
51-1	P0586051-1	INFEED TABLE

REF	PART #	DESCRIPTION
51-2	PLW07	LOCK WASHER 1/2
51-3	P0586051-3	GIB
51-4	P0586051-4	BASE
51-5	PSS01	SET SCREW 5/16-18 x 1
51-6	PN02	HEX NUT 5/16-18
51-7	P0586051-7	OUTFEED TABLE
51-8	PSB30	CAP SCREW 5/16-18 X 1/2
51-9	PW07	FLAT WASHER 5/16
51-10	P0586051-10	TABLE BRACKET
51-11	PLW04	LOCK WASHER 3/8
51-12	PSB19	CAP SCREW 3/8-16 X 1-1/4
51-13	P0586051-13	WORM GEAR
51-14	PK01M	KEY 5 X 5 X 22
51-15	P0586051-15	BRACKET
51-16	PSB44	CAP SCREW 1/2-12 X 1-3/4
51-17	PSS03	SET SCREW 1/4-20 X 3/8
51-18	P0586051-18	COLLAR
52	P0586052	CUTTERHEAD PULLEY
53	PSS02	SET SCREW 5/16-18 X 3/8
54	P0586054	BEARING HOUSING
55	P6204	RADIAL BALL BEARING 6204
56	PK01M	KEY 5 X 5 X 22
57	P0586057	CUTTERHEAD
57-1	P0586057-1	COMPRESSION SPRING
57-2	P0586057-2	JACK SCREW
57-3	P0586057-3	KNIVES-SET OF 4
57-4	P0586057-4	KNIFE GIB
57-5	P0586057-5	HEX HD GIB BOLT
58	P0586058	STUD
59	PW02	FLAT WASHER 3/8
60	PN08	HEX NUT 3/8-16
61	P0586061	SPECIAL DOUBLE END STUD
62	P0586062	BELT GUARD
63	P0586063	ROUND KNOB 5/16-18
64	PR48M	EXT RETAINING RING 11MM
65	P0586065	CUTTERHEAD GUARD
66	PRP31M	ROLL PIN 6 X 36
67	P0586067	TORSION SPRING
68	P0586068	PIVOT SHAFT
69	PRP27M	ROLL PIN 5 X 28
70	P0586070	SWIVELING LOCK HANDLE
71	P5960850	STEEL BALL 6MM
72	P0586072	DEPTH SCALE
72-1	P4000809	RIVET 2 X 5
73	P0586073	6" HANDWHEEL
73-1	P0586073-1	HANDLE
74	PW07	FLAT WASHER 5/16
75	PS38	PHLP HD SCR 5/16-18 X 1/2
76	P0586076	DEPTH POINTER
77	PS23	PHLP HD SCR 8-32 X 1/4
78	P0586078	GUARD LOCK HANDLE
79	P0586079	RABBET TABLE

Stand/Motor Parts Breakdown

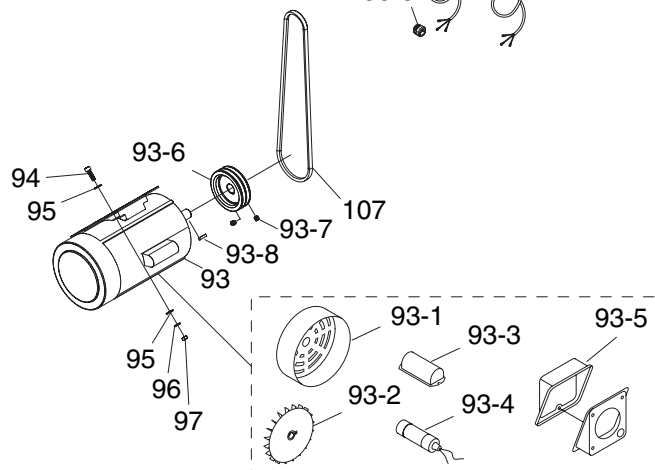
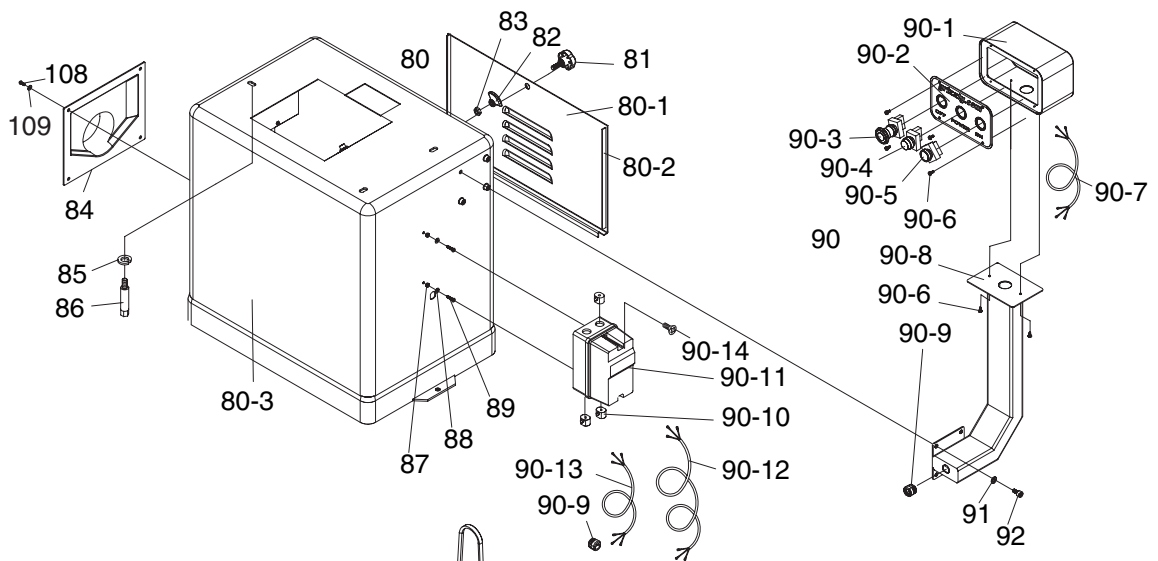
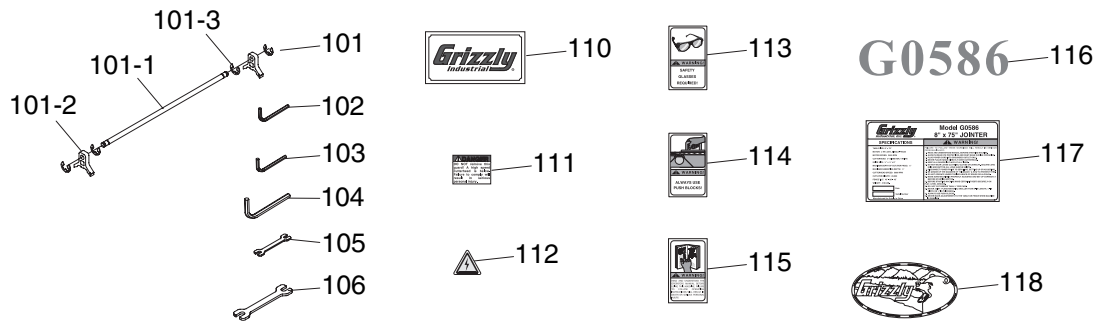

Stand/Motor Parts List

REF	PART #	DESCRIPTION
80	P0586080	STAND ASSEMBLY
80-1	P0586080-1	COVER
80-2	P0586080-2	SEAL
80-3	P0586080-3	CABINET STAND
81	P0586081	STAR KNOB 3/8-16 x 7/8
82	P0586082	LATCH
83	PN08	HEX NUT 3/8-16
84	P0586084	DUST PORT
85	PLW04	LOCK WASHER 3/8
86	P0586086	SPEICAL MOUNTING BOLT
87	PN06M	HEX NUT M5-.8
88	PW02M	FLAT WASHER 5MM
89	PS06M	PHLP HD SCR M5-.8 X 20
90	P0586090	PEDESTAL SWITCH ASSEMBLY
90-1	P0586090-1	SWITCH BOX
90-2	P0586090-2	SWITCH PANEL
90-3	P0586090-3	STOP SWITCH XB4-BS542(TE)
90-4	P0586090-4	POWER LIGHT XB4-BG21(TE)
90-5	P0586090-5	START SWITCH XB4-BA31(TE)
90-6	PS09M	PHLP HD SCR M5-.8 X 10
90-7	P0586090-7	CONTROL CORD 14AWG
90-8	P0586090-8	PEDESTAL ARM
90-9	P0586090-9	RELIEF SB8R-3
90-10	P0586090-10	STRAIN RELIEF 1/2
90-11	P0586090-11	MAGNETIC SWITCH
90-12	PWRCRD220L	POWER CORD
90-13	PWRCRD220S	MOTOR CORD
90-14	P0586090-14	PLASTIC SWITCH CVR SCREW
91	PW01M	FLAT WASHER 8MM
92	PB09M	HEX BOLT M8-1.25 X 20
93	P0586093	MOTOR
93-1	P0586093-1	FAN COVER

REF	PART #	DESCRIPTION
93-2	P0586093-2	FAN
93-3	P0586093-3	CAPACITOR COVER
93-4	PC400S	S. CAPACITOR 400M 125V
93-5	P0586093-5	JUNCTION BOX
93-6	P0586093-6	MOTOR PULLEY
93-7	PSS15	SET SCREW 3/8-16 X 3/8
93-8	PK12M	KEY 5 X 5 X 30
94	PSB03	CAP SCREW 5/16-18 X 1
95	PW07	FLAT WASHER 5/16
96	PLW01	LOCK WASHER 5/16
97	PN02	HEX NUT 5/16-18
101	P0586101	KNIFE SETTING JIG ASSEMBLY
101-1	P0586101-1	KNIFE SETTING JIG ROD
101-2	P0586101-2	KNIFE SETTING JIG FOOT
101-3	PEC10M	E-CLIP 9MM
102	PAW03M	HEX WRENCH 3MM
103	PAW04M	HEX WRENCH 4MM
104	PAW05M	HEX WRENCH 5MM
105	PWR810	WRENCH 8 X 10
106	PWR1214	WRENCH 12 X 14
107	PVM40	V-BELT M40 3L400
108	PS07	PHLP HD SCR 1/4-20 x 3/8
109	PW06	FLAT WASHER 1/4
110	P0586110	GRIZZLY LOGO-FLAT METALLIC
111	P0586111	CUTTERHEAD GUARD WARNING
112	PLABEL-14	ELECTRICITY TRIANGLE
113	PLABEL-11	SAFETY GLASSES WARNING
114	P0586114	PUSH BLOCKS WARNING
115	PLABEL-12	READ MANUAL WARNING
116	P0586116	G0586 MODEL NUMBER LABEL
117	G8588	CAST GRIZZLY LOGO PLATE

WARRANTY AND RETURNS

Grizzly Industrial, Inc. warrants every product it sells for a period of **1 year** to the original purchaser from the date of purchase. This warranty does not apply to defects due directly or indirectly to misuse, abuse, negligence, accidents, repairs or alterations or lack of maintenance. This is Grizzly's sole written warranty and any and all warranties that may be implied by law, including any merchantability or fitness, for any particular purpose, are hereby limited to the duration of this written warranty. We do not warrant or represent that the merchandise complies with the provisions of any law or acts unless the manufacturer so warrants. In no event shall Grizzly's liability under this warranty exceed the purchase price paid for the product and any legal actions brought against Grizzly shall be tried in the State of Washington, County of Whatcom.

We shall in no event be liable for death, injuries to persons or property or for incidental, contingent, special, or consequential damages arising from the use of our products.

To take advantage of this warranty, contact us by mail or phone and give us all the details. We will then issue you a "Return Number," which must be clearly posted on the outside as well as the inside of the carton. We will not accept any item back without this number. Proof of purchase must accompany the merchandise.

The manufacturers reserve the right to change specifications at any time because they constantly strive to achieve better quality equipment. We make every effort to ensure that our products meet high quality and durability standards and we hope you never need to use this warranty.

Please feel free to write or call us if you have any questions about the machine or the manual.

Thank you again for your business and continued support. We hope to serve you again soon.



WARRANTY CARD

Name _____
 Street _____
 City _____ State _____ Zip _____
 Phone # _____ Email _____ Invoice # _____
 Model # _____ Order # _____ Serial # _____

The following information is given on a voluntary basis. It will be used for marketing purposes to help us develop better products and services. **Of course, all information is strictly confidential.**

1. How did you learn about us?

Advertisement Friend Catalog
 Card Deck Website Other:

2. Which of the following magazines do you subscribe to?

<input type="checkbox"/> Cabinet Maker	<input type="checkbox"/> Popular Mechanics	<input type="checkbox"/> Today's Homeowner
<input type="checkbox"/> Family Handyman	<input type="checkbox"/> Popular Science	<input type="checkbox"/> Wood
<input type="checkbox"/> Hand Loader	<input type="checkbox"/> Popular Woodworking	<input type="checkbox"/> Wooden Boat
<input type="checkbox"/> Handy	<input type="checkbox"/> Practical Homeowner	<input type="checkbox"/> Woodshop News
<input type="checkbox"/> Home Shop Machinist	<input type="checkbox"/> Precision Shooter	<input type="checkbox"/> Woodsmith
<input type="checkbox"/> Journal of Light Cont.	<input type="checkbox"/> Projects in Metal	<input type="checkbox"/> Woodwork
<input type="checkbox"/> Live Steam	<input type="checkbox"/> RC Modeler	<input type="checkbox"/> Woodworker West
<input type="checkbox"/> Model Airplane News	<input type="checkbox"/> Rifle	<input type="checkbox"/> Woodworker's Journal
<input type="checkbox"/> Modeltec	<input type="checkbox"/> Shop Notes	<input type="checkbox"/> Other:
<input type="checkbox"/> Old House Journal	<input type="checkbox"/> Shotgun News	

3. What is your annual household income?

\$20,000-\$29,000 \$30,000-\$39,000 \$40,000-\$49,000
 \$50,000-\$59,000 \$60,000-\$69,000 \$70,000+

4. What is your age group?

20-29 30-39 40-49
 50-59 60-69 70+

5. How long have you been a woodworker/metalworker?

0-2 Years 2-8 Years 8-20 Years 20+ Years

6. How many of your machines or tools are Grizzly?

0-2 3-5 6-9 10+

7. Do you think your machine represents a good value?

Yes No

8. Would you recommend Grizzly Industrial to a friend?

Yes No

9. Would you allow us to use your name as a reference for Grizzly customers in your area?

Note: We never use names more than 3 times. Yes No

10. Comments: _____

CUT ALONG DOTTED LINE

FOLD ALONG DOTTED LINE



Place
Stamp
Here



GRIZZLY INDUSTRIAL, INC.
P.O. BOX 2069
BELLINGHAM, WA 98227-2069



FOLD ALONG DOTTED LINE

Send a Grizzly Catalog to a friend:

Name _____
Street _____
City _____ State _____ Zip _____

TAPE ALONG EDGES--PLEASE DO NOT STAPLE

grizzly.com

TOOL WEBSITE

Buy Direct and Save with Grizzly® – Trusted, Proven and a Great Value!

Visit Our Website Today And Discover Why
Grizzly® Is The Industry Leader!

- 
- 
- 

B

A

B

G

1-800-523-4777

