

Grizzly *Industrial, Inc.*®

MODEL G0517 MILL/DRILL INSTRUCTION MANUAL



COPYRIGHT © MAY, 2006 BY GRIZZLY INDUSTRIAL, INC.
**WARNING: NO PORTION OF THIS MANUAL MAY BE REPRODUCED IN ANY SHAPE
OR FORM WITHOUT THE WRITTEN APPROVAL OF GRIZZLY INDUSTRIAL, INC.**
#TR8234 PRINTED IN CHINA.

 **WARNING!**

This manual provides critical safety instructions on the proper setup, operation, maintenance and service of this machine/equipment.

Failure to read, understand and follow the instructions given in this manual may result in serious personal injury, including amputation, electrocution or death.

The owner of this machine/equipment is solely responsible for its safe use. This responsibility includes but is not limited to proper installation in a safe environment, personnel training and usage authorization, proper inspection and maintenance, manual availability and comprehension, application of safety devices, blade/cutter integrity, and the usage of personal protective equipment.

The manufacturer will not be held liable for injury or property damage from negligence, improper training, machine modifications or misuse.

 **WARNING!**

Some dust created by power sanding, sawing, grinding, drilling, and other construction activities contains chemicals known to the State of California to cause cancer, birth defects or other reproductive harm. Some examples of these chemicals are:

- **Lead from lead-based paints.**
- **Crystalline silica from bricks, cement and other masonry products.**
- **Arsenic and chromium from chemically-treated lumber.**

Your risk from these exposures varies, depending on how often you do this type of work. To reduce your exposure to these chemicals: Work in a well ventilated area, and work with approved safety equipment, such as those dust masks that are specially designed to filter out microscopic particles.

Table of Contents

INTRODUCTION	2
Foreword	2
Contact Info.....	2
Machine Data Sheet.....	3
Identification	5
SECTION 1: SAFETY	6
Safety Instructions for Machinery.....	6
Additional Safety for Mill/Drills.....	8
SECTION 2: CIRCUIT REQUIREMENTS	9
Operation.....	9
SECTION 3: SET UP	10
Items Needed for Set Up	10
Unpacking	10
Inventory.....	10
Clean Up	11
Site Considerations	11
Assembly.....	12
Test Run.....	14
SECTION 4: OPERATIONS	15
Head/Quill Travel	15
Table Travel	15
Installing/Removing Morse Taper Sleeves.....	16
Installing/Removing Drawbar Tooling	17
Installing Drill Chuck.....	18
Changing Speeds.....	18
Drilling	19
Drilling Speeds	20
Milling Speed.....	21
SECTION 5: ACCESSORIES	22
SECTION 6: MAINTENANCE	24
Schedule	24
Unpainted Cast Iron	24
Lubrication.....	24
Adjusting Gibs	25
SECTION 7: SERVICE	26
About Service.....	26
Troubleshooting.....	26
Electrical Components	28
Wiring Diagram	28
Stand/Base Parts Breakdown	29
Stand/Base Parts List.....	30
Headstock Parts Breakdown.....	31
Headstock Parts List	32
WARRANTY AND RETURNS	33

INTRODUCTION

Foreword

We are proud to offer the Model G0517 Mill/Drill. This machine is part of a growing Grizzly family of fine woodworking and metalworking machinery. When used according to the guidelines set forth in this manual, you can expect years of trouble-free, enjoyable operation and proof of Grizzly's commitment to customer satisfaction.

We are pleased to provide this manual with the Model G0517. It was written to guide you through assembly, review safety considerations, and cover general operating procedures. It represents our effort to produce the best documentation possible.

The specifications, drawings, and photographs illustrated in this manual represent the Model G0517 as supplied when the manual was prepared. However, owing to Grizzly's policy of continuous improvement, changes may be made at any time with no obligation on the part of Grizzly. For your convenience, we always keep current Grizzly manuals available on our website at **www.grizzly.com**. Any updates to your machine will be reflected in these manuals as soon as they are complete. Visit our site often to check for the latest updates to this manual!

Contact Info

If you have any comments regarding this manual, please write to us at the address below:

Grizzly Industrial, Inc.
c/o Technical Documentation Manager
P.O. Box 2069
Bellingham, WA 98227-2069

We stand behind our machines. If you have any service questions or parts requests, please call or write us at the location listed below.

Grizzly Industrial, Inc.
1203 Lycoming Mall Circle
Muncy, PA 17756
Phone: (570) 546-9663
Fax: (800) 438-5901
E-Mail: techsupport@grizzly.com
Web Site: <http://www.grizzly.com>





MACHINE DATA SHEET

Customer Service #: (570) 546-9663 · To Order Call: (800) 523-4777 · Fax #: (800) 438-5901

MODEL G0517 MILL/DRILL W/ STAND

Product Dimensions:

Weight..... 331 lbs.
 Length/Width/Height.....29-1/2 x 27-1/8 x 77-5/8 in.
 Foot Print (Length/Width)..... 17-3/4 x 14-1/2 in.

Shipping Dimensions:

Carton #1

Type..... Wood Crate
 Content..... Machine
 Weight..... 330 lbs.
 Length/Width/Height..... 27 x 23 x 23 in.

Carton #2

Type..... Cardboard
 Content..... Stand
 Weight..... 77 lbs.
 Length/Width/Height..... 37 x 20 x 16 in.

Electrical:

Switch..... Toggle
 Switch Voltage..... 110V
 Cord Length..... 6 ft.
 Cord Gauge..... 18 gauge
 Recommended Breaker Size..... 15 amp
 Plug..... Yes

Motors:

Main

Type..... TEFC Capacitor Start Induction
 Horsepower..... 1/2 HP
 Voltage..... 110V
 Prewired..... 110V
 Phase..... Single
 Amps..... 8.5A
 Speed..... 1725 RPM
 Cycle..... 60 Hz
 Number Of Speeds..... 1
 Power Transfer V-Belt Drive
 Bearings..... Shielded, Permanently Lubricated

The information contained herein is deemed accurate as of 5/12/2006 and represents our most recent product specifications. Due to our ongoing improvement efforts, this information may not accurately describe items previously purchased.



Main Specifications:

Operation Info

Spindle Travel.....	3-1/8 in.
Swing.....	14-1/2 in.
Longitudinal Table Travel.....	9-1/4 in.
Cross Table Travel.....	5-3/4 in.
Head Swivel.....	360 deg.
Max. Dist Spindle To Column.....	7-1/4 in.
Max. Dist Spindle To Table.....	14 in.
Drilling Cap For Cast Iron.....	5/8 in.
Drilling Cap For Steel.....	5/8 in.
No. Of Vert. Spindle Speeds.....	12
Range Of Vert. Spindle Speeds.....	300, 400, 540, 720, 900, 1040, 1500, 1740, 2100, 2260, 3100, 3840 RPM
Quill Dia.....	1-7/8 in.

Table Info

Table Length.....	16-1/2 in.
Table Width.....	6-1/8 in.
Table Thickness.....	1-1/8 in.
No. Of T Slots.....	2
T Slots Width.....	1/2 in.
T Slots Height.....	5/8 in.
T Slots Centers.....	3-3/8 in.
Stud Size.....	1/2 in.

Lead Screw Info

Lead Screw Diameter.....	0.740 in.
Lead Screw TPI.....	6
Lead Screw Length.....	23 in.

Construction

Spindle Housing Const.....	Cast Iron
Table Const.....	Precision Ground Cast Iron
Head Const.....	Cast Iron
Column Const.....	Cast Iron
Base Const.....	Precision Ground Cast Iron
Stand Const.....	Welded Steel
Paint.....	Enamel

Other

Collars Calibrated.....	0.001 in.
Column Dia.....	2-7/8 in.
Mobile Base.....	G8683

Spindle Info

Spindle Taper.....	MT#3
End Milling Cap.....	1/4 in.
Face Milling Cap.....	3/4 in.
Draw Bar Diameter.....	12 mm
Draw Bar TPI.....	M12 - 1.75
Draw Bar Length.....	11-7/8 in.
Spindle Bearings.....	Ball Bearing

Other Specifications:

ISO Factory	ISO 9001
Country Of Origin	China
Warranty	1 Year
Serial Number Location	ID Label on Head Casting
Assembly Time	1-1/2 hours

The information contained herein is deemed accurate as of 5/12/2006 and represents our most recent product specifications. Due to our ongoing improvement efforts, this information may not accurately describe items previously purchased.



Identification

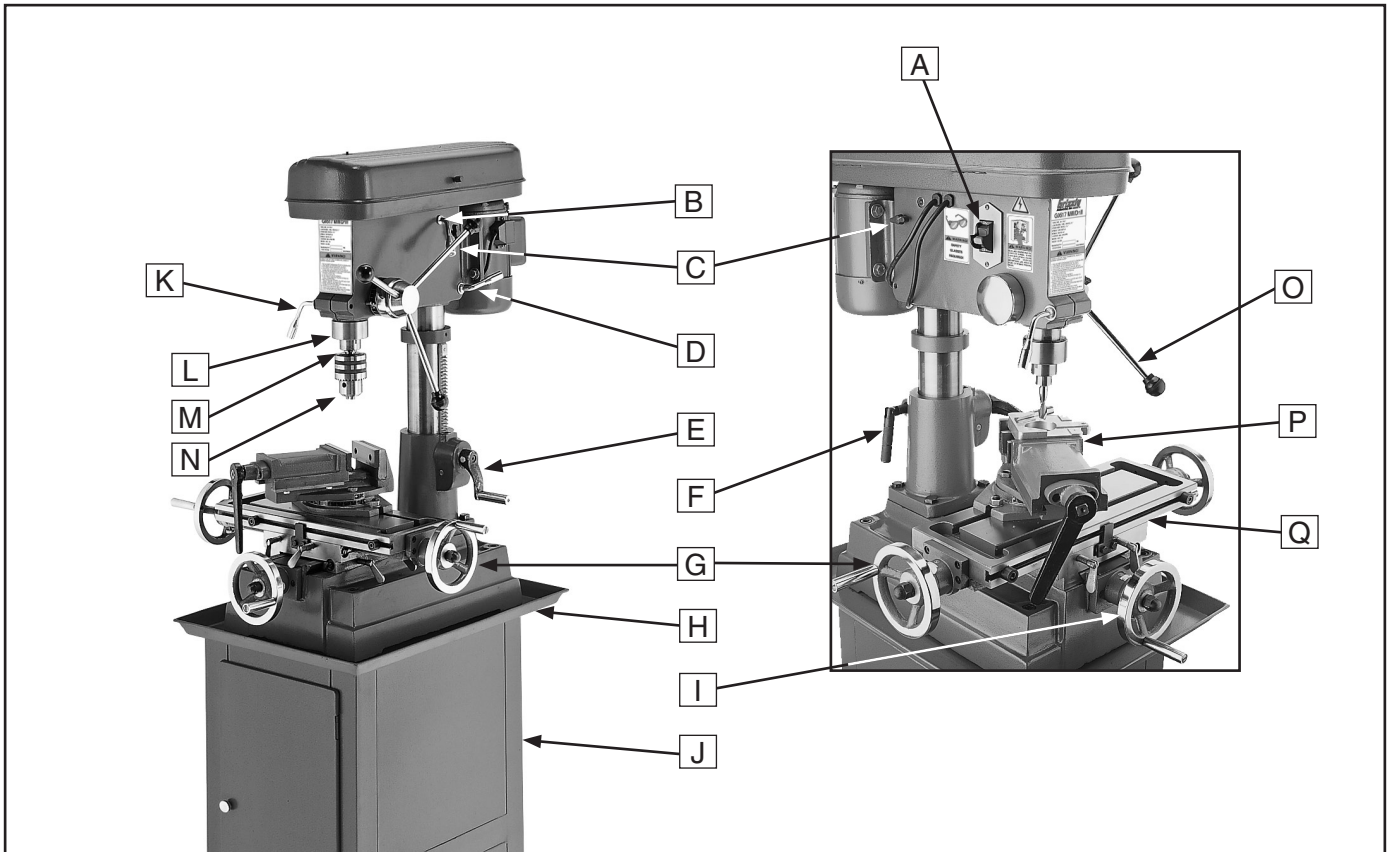

- A. ON/OFF Switch w/Safety Key
- B. Belt Tension Handle
- C. Belt Tension Locks
- D. Headstock Clamp Handle
- E. Head Elevation Crank (Z Axis, Major)
- F. Column Lock
- G. Longitudinal Handwheels (X Axis)
- H. Splash Tray
- I. Cross Feed Handwheel (Y Axis)
- J. Cabinet Stand
- K. Quill Lock
- L. Quill
- M. Arbor
- N. Drill Chuck
- O. Downfeed Handle (Z Axis, Minor)
- P. Vise
- Q. Milling Table



SECTION 1: SAFETY

WARNING

For Your Own Safety, Read Instruction Manual Before Operating this Machine

The purpose of safety symbols is to attract your attention to possible hazardous conditions. This manual uses a series of symbols and signal words which are intended to convey the level of importance of the safety messages. The progression of symbols is described below. Remember that safety messages by themselves do not eliminate danger and are not a substitute for proper accident prevention measures.

 **DANGER** Indicates an imminently hazardous situation which, if not avoided, **WILL** result in death or serious injury.

 **WARNING** Indicates a potentially hazardous situation which, if not avoided, **COULD** result in death or serious injury.

 **CAUTION** Indicates a potentially hazardous situation which, if not avoided, **MAY** result in minor or moderate injury. It may also be used to alert against unsafe practices.

NOTICE This symbol is used to alert the user to useful information about proper operation of the machine.

WARNING

Safety Instructions for Machinery

- 1. READ THROUGH THE ENTIRE MANUAL BEFORE STARTING MACHINERY.** Machinery presents serious injury hazards to untrained users.
- 2. ALWAYS USE ANSI APPROVED SAFETY GLASSES WHEN OPERATING MACHINERY.** Everyday eyeglasses only have impact resistant lenses—they are NOT safety glasses.
- 3. ALWAYS WEAR A NIOSH APPROVED RESPIRATOR WHEN OPERATING MACHINERY THAT PRODUCES DUST.** Wood dust is a carcinogen and can cause cancer and severe respiratory illnesses.
- 4. ALWAYS USE HEARING PROTECTION WHEN OPERATING MACHINERY.** Machinery noise can cause permanent hearing damage.
- 5. WEAR PROPER APPAREL. DO NOT** wear loose clothing, gloves, neckties, rings, or jewelry which may get caught in moving parts. Wear protective hair covering to contain long hair and wear non-slip footwear.
- 6. NEVER OPERATE MACHINERY WHEN TIRED, OR UNDER THE INFLUENCE OF DRUGS OR ALCOHOL.** Be mentally alert at all times when running machinery.



WARNING

Safety Instructions for Machinery

7. **ONLY ALLOW TRAINED AND PROPERLY SUPERVISED PERSONNEL TO OPERATE MACHINERY.** Make sure operation instructions are safe and clearly understood.
8. **KEEP CHILDREN AND VISITORS AWAY.** Keep all children and visitors a safe distance from the work area.
9. **MAKE WORKSHOP CHILD PROOF.** Use padlocks, master switches, and remove start switch keys.
10. **NEVER LEAVE WHEN MACHINE IS RUNNING.** Turn power **OFF** and allow all moving parts to come to a complete stop before leaving machine unattended.
11. **DO NOT USE IN DANGEROUS ENVIRONMENTS.** DO NOT use machinery in damp, wet locations, or where any flammable or noxious fumes may exist.
12. **KEEP WORK AREA CLEAN AND WELL LIT.** Clutter and dark shadows may cause accidents.
13. **USE A GROUNDED EXTENSION CORD RATED FOR THE MACHINE AMPERAGE.** Undersized cords overheat and lose power. Replace extension cords if they become damaged. DO NOT use extension cords for 220V machinery.
14. **ALWAYS DISCONNECT FROM POWER SOURCE BEFORE SERVICING MACHINERY.** Make sure switch is in OFF position before reconnecting.
15. **MAINTAIN MACHINERY WITH CARE.** Keep blades sharp and clean for best and safest performance. Follow instructions for lubricating and changing accessories.
16. **MAKE SURE GUARDS ARE IN PLACE AND WORK CORRECTLY BEFORE USING MACHINERY.**
17. **REMOVE ADJUSTING KEYS AND WRENCHES.** Make a habit of checking for keys and adjusting wrenches before turning machinery **ON**.
18. **CHECK FOR DAMAGED PARTS BEFORE USING MACHINERY.** Check for binding and alignment of parts, broken parts, part mounting, loose bolts, and any other conditions that may affect machine operation. Repair or replace damaged parts.
19. **USE RECOMMENDED ACCESSORIES.** Refer to the instruction manual for recommended accessories. The use of improper accessories may cause risk of injury.
20. **DO NOT FORCE MACHINERY.** Work at the speed for which the machine or accessory was designed.
21. **SECURE WORKPIECE.** Use clamps or a vise to hold the workpiece when practical. A secured workpiece protects your hands and frees both hands to operate the machine.
22. **DO NOT OVERREACH.** Keep proper footing and balance at all times.
23. **MANY MACHINES WILL EJECT WORKPIECE TOWARD OPERATOR.** Know and avoid conditions that cause the workpiece to "kickback."
24. **ALWAYS LOCK MOBILE BASES (IF USED) BEFORE OPERATING MACHINERY.**
25. **BE AWARE THAT CERTAIN WOODS MAY CAUSE AN ALLERGIC REACTION** in people and animals, especially when exposed to fine dust. Make sure you know what type of wood dust you will be exposed to and always wear an approved respirator.



WARNING

Additional Safety for Mill/Drills

- 1. EYE/FACE/HAND PROTECTION.** Wear safety glasses or face shield when using this machine. Always keep hands and fingers away from cutting tool. **DO NOT** wear gloves when operating the machine.
- 2. SECURING BIT.** Properly tighten the cutting tool before using this machine.
- 3. BE ATTENTIVE.** **DO NOT** leave machine running unattended for any reason.
- 4. ADJUSTING KEYS AND WRENCHES.** Remove all adjusting keys and wrenches before starting machine.
- 5. WORKHOLDING.** Before starting machine, be certain the workpiece has been properly clamped to the table. Position work so you avoid drilling into the table. **NEVER** hold the workpiece by hand during operation.
- 6. HEADSTOCK LOCK.** Make sure the headstock lock is tightened before starting the machine.
- 7. SURFACE/WORKPIECE PREP.** Clear the table of all objects (tools, scrap wood, etc.) before starting machine. Unless a suitable support is used, **DO NOT** drill material that does not have a flat surface.
- 8. DAMAGED TOOLS.** Never use cutting tools in poor condition. Dull or damaged cutting tools are hard to control and may cause serious injury.
- 9. OPERATION.** Never start the machine with the cutting tool pressed against the workpiece. Feed the cutting tool evenly into the workpiece. Back the drill bit out of deep holes to clear chips when drilling.
- 10. AVOIDING ENTANGLEMENT.** When operating machine, keep loose clothing articles such as sleeves, belts or jewelry items away from the spindle and **DO NOT** wear gloves.
- 11. OPERATING SPEED.** Always operate your mill/drill at speeds that are appropriate for the bit size and the workpiece material.
- 12. MAINTENANCE/SPEED CHANGES.** Never perform maintenance or speed changes with the machine connected to power.
- 13. EXPERIENCING DIFFICULTIES.** If at any time you are experiencing difficulties performing the intended operation, stop using the machine! Contact our Tech Support at (570) 546-9663.

WARNING

Like all machines there is danger associated with this machine. Accidents are frequently caused by lack of familiarity or failure to pay attention. Use this machine with respect and caution to lessen the possibility of operator injury. If normal safety precautions are overlooked or ignored, serious personal injury may occur.

CAUTION

No list of safety guidelines can be complete. Every shop environment is different. Always consider safety first, as it applies to your individual working conditions. Use this and other machinery with caution and respect. Failure to do so could result in serious personal injury, damage to equipment, or poor work results.



SECTION 2: CIRCUIT REQUIREMENTS

Operation

!WARNING

Serious personal injury could occur if you connect the machine to the power source before you have completed the set up process. **DO NOT** connect the machine to the power source until instructed to do so.

Amperage Draw

The Model G0517 motor draws the following amps under maximum load:

Motor Draw 8.5 Amps

Circuit Recommendations

We recommend using a dedicated circuit for this machine. You **MUST** connect your machine to a grounded circuit that is at least rated for the amperage given below. Never replace a circuit breaker on an existing circuit with one of higher amperage without consulting a qualified electrician to ensure compliance with wiring codes. **If you are unsure about the wiring codes in your area or you plan to connect your machine to a shared circuit, consult a qualified electrician.**

110V Circuit 15 Amps

Plug/Receptacle Type

Included Plug Type NEMA 5-15

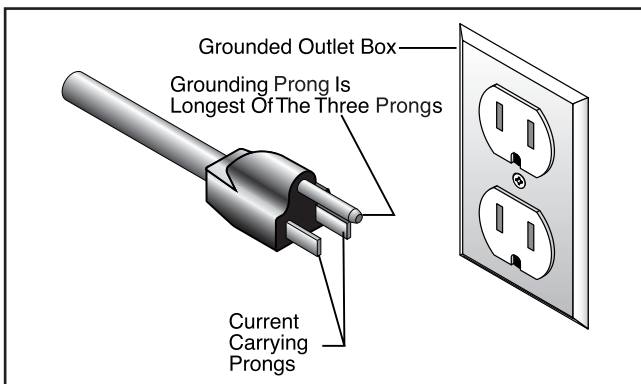

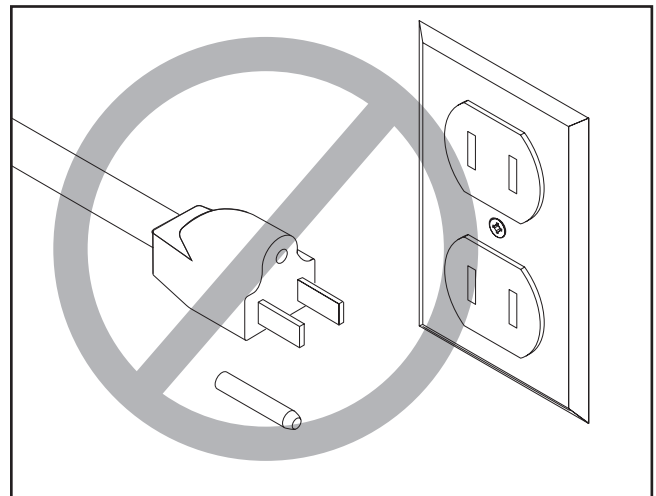

Figure 1. Typical 5-15 plug and receptacle.



!WARNING

Electrocution or fire could result if this machine is not grounded correctly or if your electrical configuration does not comply with local and state codes. Ensure compliance by checking with a qualified electrician!



!CAUTION

This machine must have a ground prong in the plug to help ensure that it is grounded. **DO NOT** remove ground prong from plug to fit into a two-pronged outlet! If the plug will not fit the outlet, have the proper outlet installed by a qualified electrician.

Extension Cords

We do not recommend the use of extension cords, but if you find it absolutely necessary:

- Use at least a 16 gauge cord that does not exceed 50 feet in length!
- The extension cord must also contain a ground wire and plug pin.
- A qualified electrician **MUST** size cords over 50 feet long to prevent motor damage.



SECTION 3: SET UP

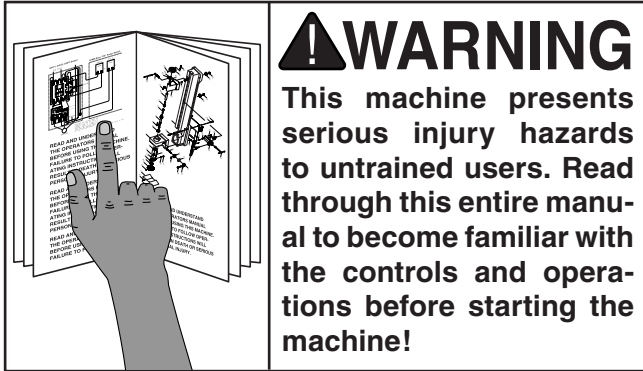

Items Needed for Set Up

The following items are needed to complete the set up process, but are not included with your machine:

Description	Qty
• Degreaser.....	Varies
• Throw-Away Rags.....	Varies
• Wrench/Socket 17mm.....	1
• Wrench/Socket 19mm.....	1
• Flat Head Screwdriver.....	1
• Another Person for Lifting Help.....	1

Unpacking

The Model G0517 was carefully packed when it left our warehouse. If you discover the machine is damaged after you have signed for delivery, *please immediately call Customer Service at (570) 546-9663 for advice.*

Save the containers and all packing materials for possible inspection by the carrier or its agent. *Otherwise, filing a freight claim can be difficult.*

When you are completely satisfied with the condition of your shipment, you should inventory the contents.

Inventory

After all the parts have been removed from the two boxes, you should have the following items:

Description	Qty
A. Stand.....	1
B. Base Assembly.....	1
C. Headstock.....	1
D. Splash Tray.....	1
E. T-Bolts and Washers.....	2
F. Milling Vise w/Handle.....	1
G. Downfeed Handle Shafts w/Ball Knobs.....	3
H. Handwheel Handles.....	3
I. Drill Chuck Arbor.....	1
J. Drawbar M12-1.75.....	1
K. MT #2/#3 & MT#1/#2 Sleeves.....	1 Each
L. Wrenches and Drift Key.....	1 Each
M. Mounting Bolts, Washers, Nuts.....	4 Each
N. Drill Chuck & Key.....	1 Each

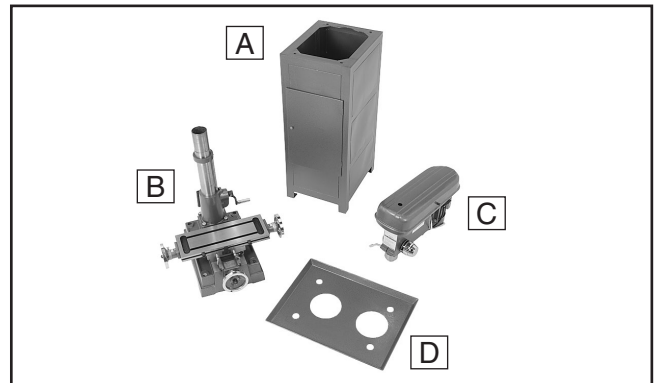

Figure 2. Main parts inventory.

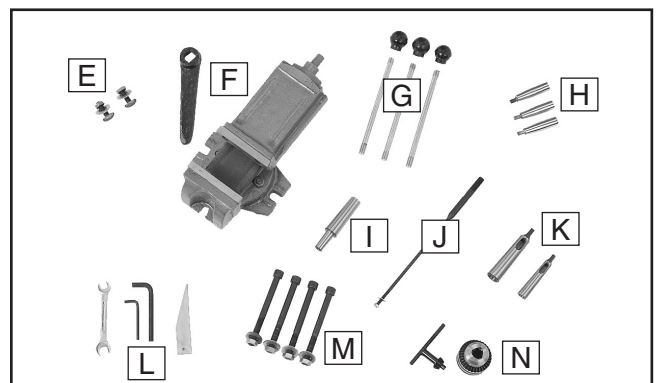

Figure 3. Component inventory.



Clean Up

The unpainted surfaces are coated with a waxy oil to protect them from corrosion during shipment. Remove this protective coating with a solvent cleaner or citrus-based degreaser such as Grizzly's G7895 Degreaser.

Some parts may need to be removed before they can be thoroughly cleaned.

For optimum performance from your machine, make sure you clean all moving parts or sliding contact surfaces that are coated.

Avoid chlorine-based solvents, such as acetone or brake parts cleaner, as they may damage painted surfaces should they come in contact. Always follow the manufacturer's instructions when using any type of cleaning product.

	<p>⚠ WARNING Gasoline and petroleum products have low flash points and could cause an explosion or fire if used to clean machinery. DO NOT use gasoline or petroleum products to clean the machinery.</p>
--	---

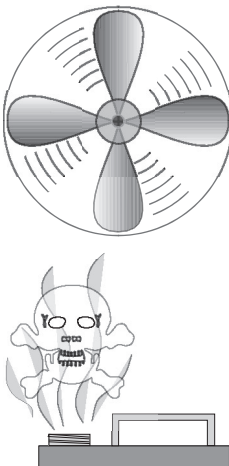
	<p>⚠ CAUTION Many of the solvents commonly used to clean machinery can be toxic when inhaled or ingested. Lack of ventilation while using these solvents could cause serious personal health risks or fire. Take precautions from this hazard by only using cleaning solvents in a well ventilated area.</p>
---	---

Site Considerations

Floor Load

Refer to the **Machine Data Sheet** for the weight and footprint specifications of your machine. Some residential floors may require additional reinforcement to support the machine, workpiece, and operator.

Minimum Working Clearances

Consider existing and anticipated needs, size of material to be processed through each machine, and space for auxiliary stands, work tables or other machinery when establishing a location for your new machine. See **Figure 4** for the minimum working clearances.

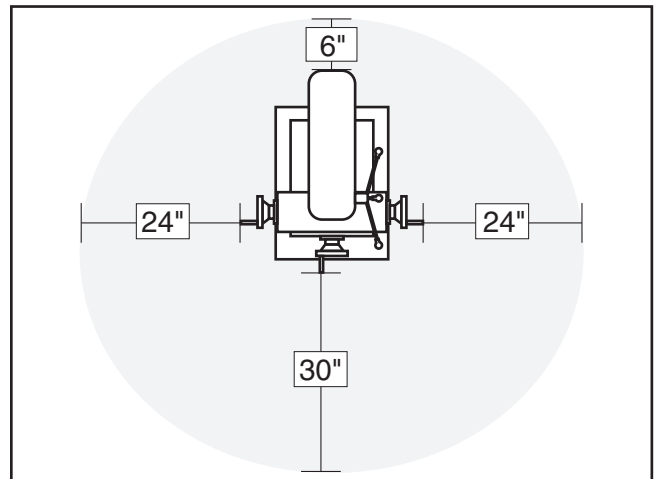

Figure 4. Overhead view of minimum working clearances.

	<p>⚠ CAUTION Unsupervised children and visitors inside your shop could cause serious personal injury to themselves. Lock all entrances to the shop when you are away and DO NOT allow unsupervised children or visitors in your shop at any time!</p>
--	---



Assembly

Before assembling your new mill/drill, determine if you will bolt your stand to the floor or use machine mounts. Machine mounts, shown in **Figure 5**, give the advantage of fast leveling and vibration reduction. For the Model G0517, we recommend using four Grizzly Model G7159 machine mounts.



Figure 5. Machine mount example.

Bolting the machine to the floor is the strongest option, but also the most permanent.

Lag shield anchors with lag bolts (**Figure 6**) and anchor studs (**Figure 7**) are two popular methods for anchoring an object to a concrete floor.

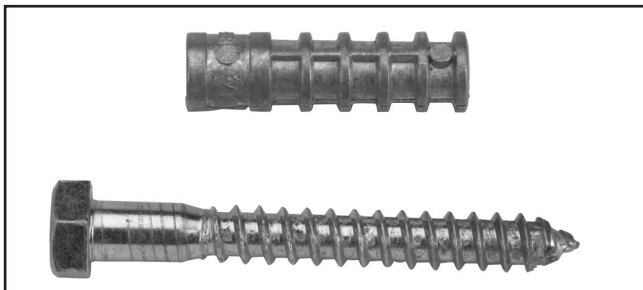

Figure 6. Typical lag shield anchor and lag bolt.

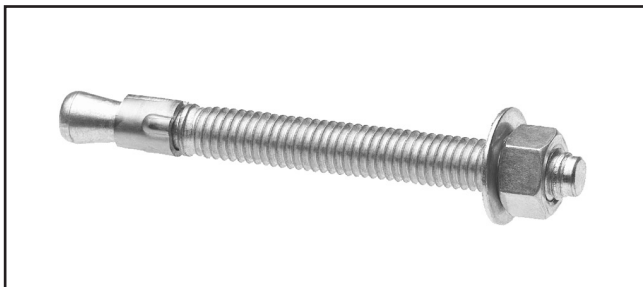

Figure 7. Typical anchor stud.

To assemble the mill/drill:

1. Mount the stand to the floor in your desired location.
2. Place the splash tray on top of the stand, as shown in **Figure 8**, and align the mounting holes.

Note: Take care to install the splash tray in the same orientation as shown in **Figure 8**. Installing the splash tray backwards will limit column movement.

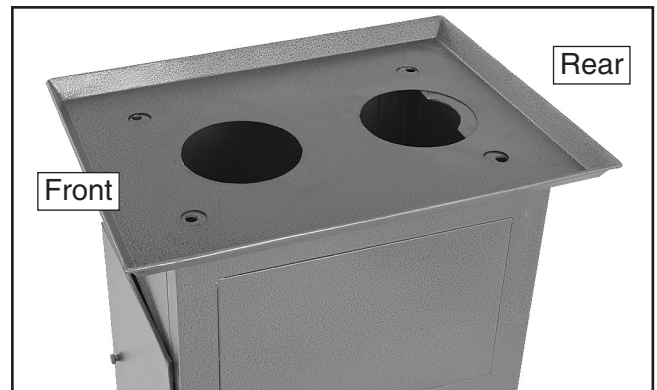

Figure 8. Splash tray placed on the stand in the correct orientation.

3. With the help of an assistant, place the base assembly on top of the splash tray and align the mounting holes.
4. Fasten the base assembly to the stand with the mounting bolts, flat washers, and hex nuts provided (see **Figure 9**).

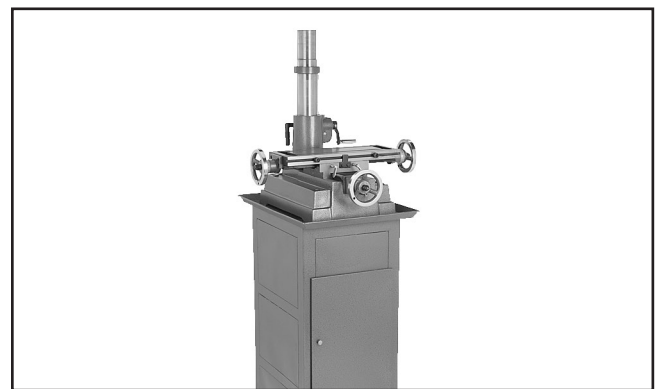

Figure 9. Base assembly attached to stand.



5. With the help of an assistant, place the mill/drill headstock onto the column, as shown in **Figure 10**.

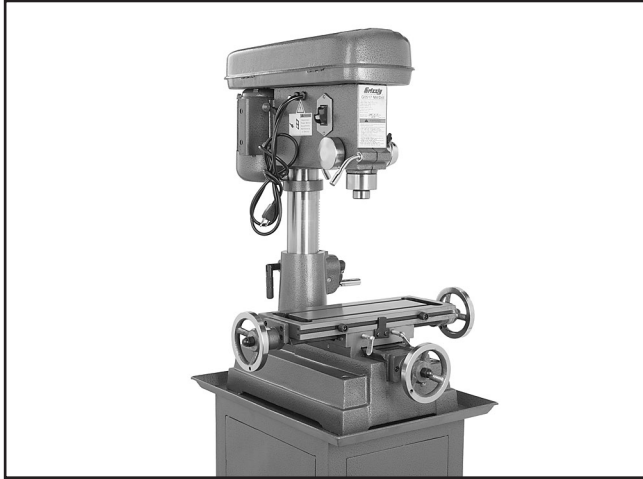

Figure 10. Headstock installed on base column.

6. Center the headstock over the table and tighten the lock handle shown in **Figure 11**.



Figure 11. Securing headstock to column.

7. Thread the handwheel handles into the handwheels, as shown in **Figure 12**.

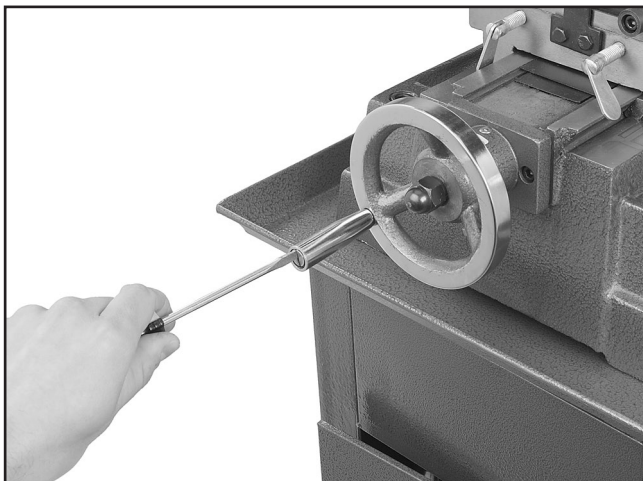

Figure 12. Installing handwheel handles.

8. Thread the ball knobs onto one end of the downfeed handle shafts (the knobs go on the end of the shaft with the shorter threads).
9. Thread the downfeed handle shaft assemblies into the pinion hub (**Figure 13**).

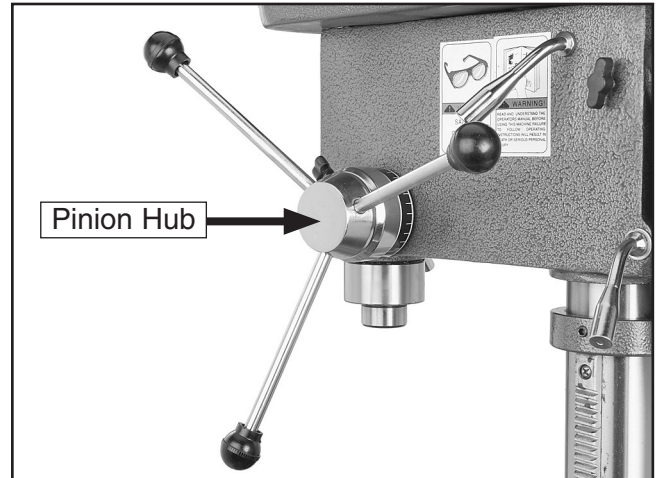

Figure 13. Downfeed handles installed.

Congratulations, your mill/drill is now assembled. For further information about installing the drill chuck or spindle sleeves, refer to the **Operations** section after performing the **Test Run**.



Test Run

The purpose of a test run is to make sure your machine and its safety components are functioning correctly. The machine should remain disconnected from power until instructed otherwise.

To test run the machine:

1. Loosen the lock knobs on both sides (**Figure 14**), tighten the V-belts by pulling and holding tension on the belt tension lever, then tighten the lock knobs.

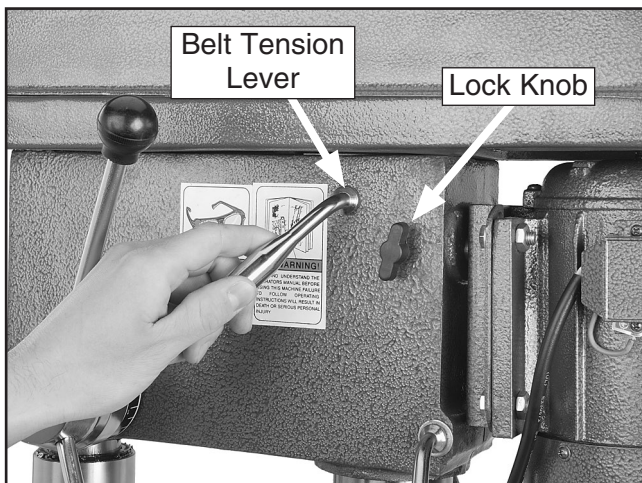

Figure 14. Using the belt tension lever to tighten/loosen the belts.

2. Clear all tools and other components away from the mill/drill, and ensure that the belt cover is closed.
3. Make sure you are familiar with the machine safety and controls.



4. Connect the drill press to the power source.
5. Turn the machine **ON**. The mill/drill should run smoothly, with little or no vibration or rubbing noises.
 - If you notice anything unusual about the operation, turn the machine **OFF**, disconnect power, and investigate/correct the problem before operating further.
 - If you cannot easily locate the source of a potential problem, refer to Troubleshooting on **Page 26** or contact our Technical Support at (570) 546-9663.
6. Remove the switch key (yellow portion of the main switch), and try to turn the switch **ON**.
 - If the machine does **NOT** turn **ON** with the key removed, then the safety feature is working as intended.
 - If the machine turns **ON** with the key removed, then the safety feature is malfunctioning. Disconnect power to the machine and contact Tech Support immediately.



SECTION 4: OPERATIONS

NOTICE

If you have never used this type of machine or equipment before, WE STRONGLY RECOMMEND that you read books, trade magazines, or get formal training before beginning any projects. Regardless of the content in this section, Grizzly Industrial will not be held liable for accidents caused by lack of training.

Head/Quill Travel

The headstock can be raised/lowered with the elevation handle and column lock for Z-axis movement (Figure 15). The quill can be raised/lowered with the downfeed handles and locked in place with the quill lock (Figure 16).

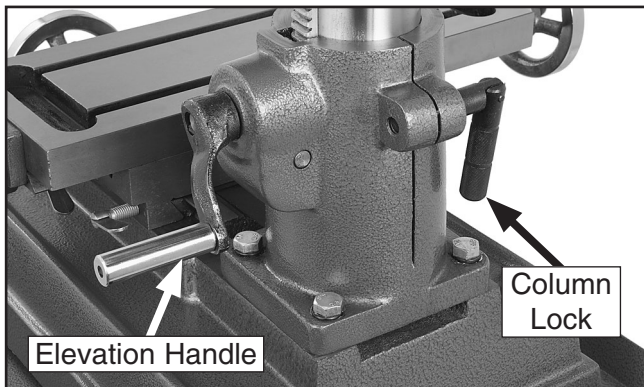

Figure 15. Headstock elevation controls.

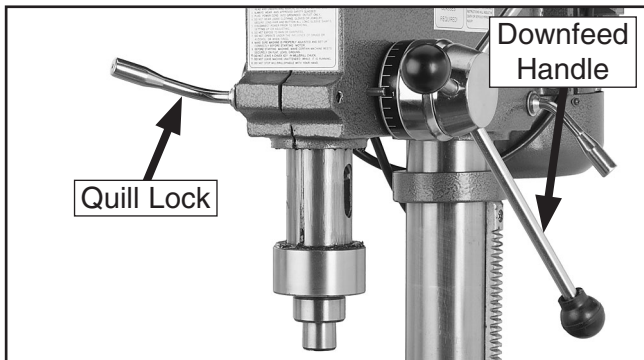

Figure 16. Quill controls.

Table Travel

The mill/drill table can be moved in the X and Y axis.

Longitudinal Feed

The longitudinal feed (X-axis) is moved by either handwheel (Figure 17) at the end of the table. One complete handwheel revolution moves the table 0.167". The longitudinal feed can be locked in position by locks located on the front of the table.

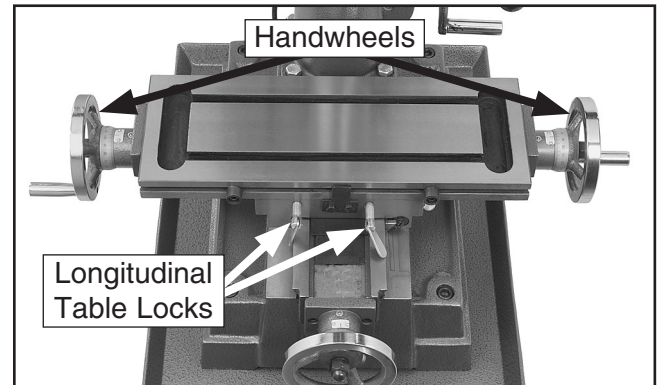

Figure 17. Longitudinal feed controls.

Cross Feed

The cross feed (Y-axis) is moved with the handwheel on the front of the table base (Figure 18). One complete revolution of the handwheel moves the cross feed table 0.167". The cross feed can be locked into position with the table locks.

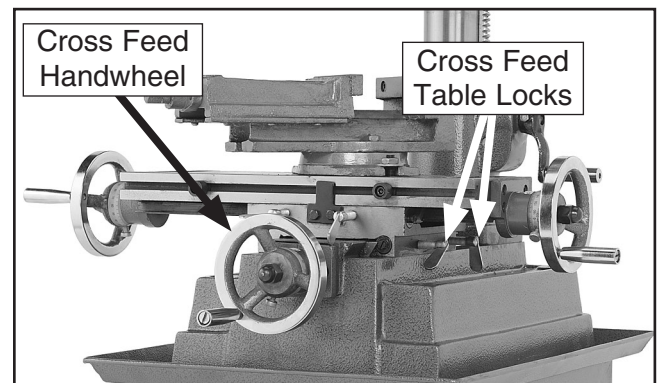

Figure 18. Cross feed controls.



Installing/Removing Morse Taper Sleeves

The Model G0517 includes an MT#1/#2 sleeve and an MT#2/#3 sleeve. Always DISCONNECT MACHINE FROM POWER when installing or removing tooling.

To install a sleeve:

1. Make sure the spindle and sleeve tapers are clean and free of any debris or grease.
2. Insert the sleeve into the spindle with the tang side up (**Figure 19**) and rotate with upward pressure until it fits into place.



Figure 19. Installing a morse taper sleeve.

3. Using a rubber mallet or brass hammer (do not use steel), tap the sleeve up into the spindle to lock it in place (**Figure 20**).



Figure 20. Tapping the sleeve into the spindle.

To remove a sleeve:

1. Lower the quill with the downfeed handle and lock it in place with the quill lock (**Figure 21**).



Figure 21. Location of quill lock.

2. Insert the drift key into the quill slot as shown in **Figure 22**.

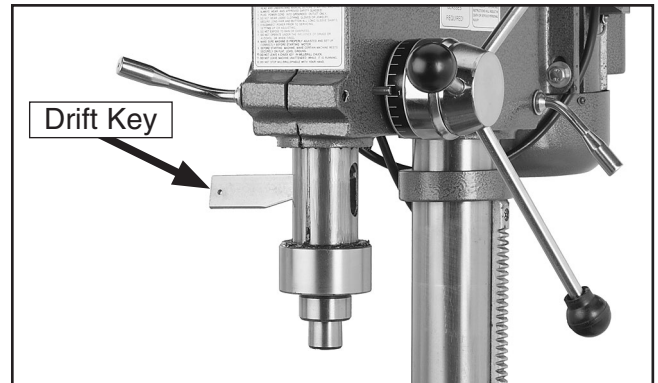

Figure 22. Drift key inserted in quill slot.

3. Hold the sleeve with one hand and gently tap the drift key with a hammer to knock the sleeve out.



Installing/Removing Drawbar Tooling

The Model G0517 includes an M12-1.75 drawbar. Use the drawbar to connect the included drill chuck arbor or an aftermarket end mill holder. See **Page 23** for recommended end mill holders.

Always DISCONNECT MACHINE FROM POWER when installing or removing tooling.

To install the drawbar with attached tooling:

1. Make sure the spindle and tooling tapers are clean and free of any debris or grease.
2. Make sure the drawbar is firmly threaded into the tooling (**Figure 23**).

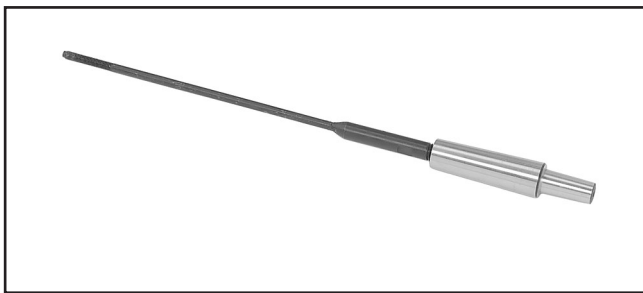

Figure 23. Drawbar threaded into the included drill chuck arbor.

3. Insert the drawbar into the spindle and lodge the tooling and spindle tapers together, as shown in **Figure 24**.



Figure 24. Inserting tooling into spindle.

4. Hand tighten the hex nut and flat washer on the drawbar threads that project out of the spindle pulley, as shown in **Figure 25**.



Figure 25. Tightening nut on drawbar.

5. Snug the drawbar hex nut down $\frac{1}{2}$ a turn.

To remove the drawbar and tooling:

1. Loosen the drawbar hex nut and unthread it to the top of the drawbar without removing it (**Figure 26**).

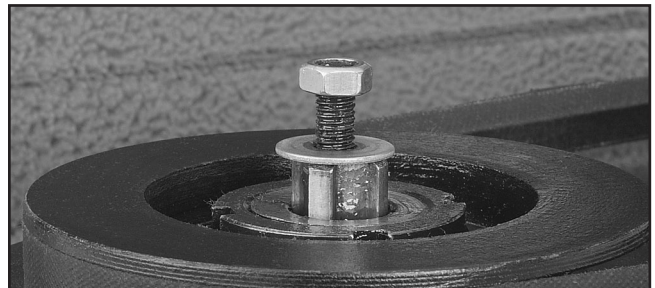

Figure 26. Nut unthreaded to top of drawbar.

2. Using a brass hammer, tap the drawbar from the top, as shown in **Figure 27**, with light blows until the tooling and spindle tapers release.

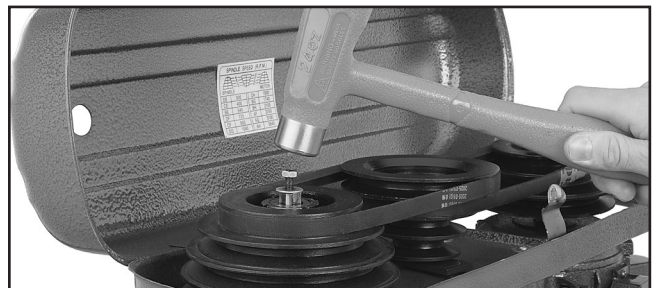

Figure 27. Tapping drawbar with hammer.

3. Hold the tooling with one hand and remove the drawbar hex nut with the other hand.
4. Remove the drawbar and tooling assembly from the spindle.



Installing Drill Chuck

The drill chuck fits on the arbor with a taper fit.

To install the drill chuck:

1. UNPLUG THE MILL/DRILL!
2. Prepare the mating surfaces on the arbor taper and the chuck by cleaning them thoroughly.
3. Retract the chuck jaws all the way inside of the chuck.
4. Push the chuck onto the arbor taper, and using a wood block and hammer or mallet as shown in **Figure 28**, hit the chuck once with moderate force to secure it on the arbor.

Note: *Hitting the chuck directly with a steel hammer may damage the chuck, making it unsafe to use.*



Figure 28. Seating the chuck on the arbor.

Changing Speeds

Belt positions on the pulleys govern the spindle speed. A chart under the belt cover shows the belt positions needed for each available speed.

To change speeds:

1. UNPLUG THE MILL/DRILL!
2. Loosen the lock knobs on each side of the headstock (**Figure 29**), and use the belt tension lever to take tension off of the V-belts.

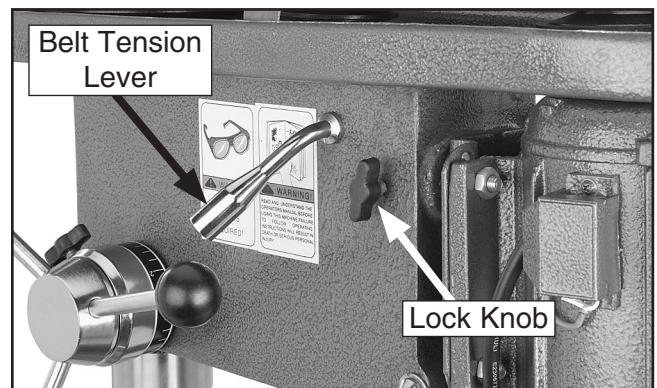

Figure 29. Loosening lock knob.

3. Find your desired speed on the speed chart (**Figure 30**) and move the V-belts to the indicated positions in the pulley grooves.



Figure 30. Speed chart.

4. Use the belt tension handle to tighten the V-belts, then tighten the lock knob and close the belt cover.



Drilling

The basic operation when drilling is lining up your drill bit with the intended hole location, clamping the workpiece to the table, turning the mill/drill **ON**, and using the downfeed handles to move the spinning drill bit into the workpiece.

For safe operation and optimum results, it is very important to follow these guidelines when drilling:

CLEARING CHIPS: Raise the drill bit often to clear chips and cool the drill bit. This will ease the work of the mill/drill motor and extend the life of your drill bits.

SECURING WORKPIECE TO TABLE: Secure the workpiece to the table or in a vise that is secured to the table before drilling.

PROTECTING TABLE: Protect the table by placing the workpiece on scrap wood, or center the location of the hole to be drilled over the pocket in the table when through drilling. Also, use the depth stop to ensure that the drill bit goes no deeper than necessary.

USING CORRECT SPEEDS: Use the correct speed for the diameter of the drill bit being used and the type of material being drilled. Refer to the **Drill Bit Speed Chart** on **Page 20** to help you choose the correct speed for your application.

LARGE DIAMETER BITS: Large diameter drill bits require slower spindle speeds.

SMALL DIAMETER BITS: Smaller diameter drill bits require faster spindle speeds.

HARD MATERIAL: The harder the material, (steel vs. wood) the slower the spindle speed.

SOFT MATERIAL: The softer the material, the faster the spindle may turn. However, plastics can melt at too high of a spindle speed.

LUBRICANT: Use some form of lubricant on all materials except wood or cast iron. Refer to **Lubrication Suggestions** on **Page 20** to find the correct lubrication for your application.

DRILLING ACCURACY: To prevent drill bit wandering and ensure accurate placement of holes, mark the hole location with a center punch before drilling. Also consider using a center-point drill to start the hole.

PLUG/ROSETTE CUTTERS: Plug cutters and rosette cutters are for wood only. However, carbide-tipped bits and cutters cut at a higher speed and can cut materials other than wood, depending on the cutter type.

5-FLUTE/2-FLUTE CUTTERS: Use a 5-flute cutter when cutting into plastics, brass, aluminum, and mild steel. A 2-flute cutter can aggressively grab the workpiece and damage the tool if used with materials other than wood.

SPADE BITS AND PLASTIC: When drilling plastic with a spade bit, use a spade bit with spurs.

HOLE SAWS: When using hole saws, apply firm and even pressure, so the saw teeth contact the surface all at the same time—not at an angle. You can also flip the workpiece and finish drilling from the other side to prevent tear-out.

CAUTION

If the workpiece is not clamped down, the operator's hand could get pulled into the bit or the workpiece can be thrown with great force. Clamp the workpiece to the table before drilling.



Drilling Speeds

Using the Drill Bit Speed Chart

The chart shown in **Figure 31** is intended as a guide only. Always follow the manufacturer's speed recommendations if provided with your drill bits, cutters, or hole saws. Exceeding the recommended speeds by large amounts may be dangerous to the operator.

The speeds shown here are intended to get you started. The optimum speed will always depend on various factors, including tool diameter, drilling pressure, material hardness, material quality, and desired finish.

Often, when drilling materials other than wood, some type of lubrication is necessary.

Lubrication Suggestions

Wood or Cast Iron None
 Plastics Soapy Water
 Brass Water-Based Lubricant
 Aluminum.....Paraffin-Based Lubricant
 Mild Steel.....Oil-Based Lubricant

⚠ CAUTION

If the workpiece is not clamped down, the operator's hand could get pulled into the bit or the workpiece can be thrown with great force. Clamp the workpiece to the table before drilling.

Twist/Brad Point Drill Bits	Soft Wood	Hard Wood	Plastic	Brass	Aluminum	Mild Steel
1/16" – 3/16"	3000	2500	2500	2500	3000	2500
13/64" – 3/8"	2000	1500	2000	1250	2500	1250
25/64" – 5/8"	1500	750	1500	750	1500	600
11/16" – 1"	750	500	1000	400	1000	350

Spade/Forstner Bits	Soft Wood	Hard Wood	Plastic	Brass	Aluminum	Mild Steel
1/4" – 1/2"	2000	1500	/	/	/	/
9/16" – 1"	1500	1250	/	/	/	/
1-1/8" – 1-7/8"	1000	750	/	/	/	/
2–3"	500	350	/	/	/	/

Hole Saws	Soft Wood	Hard Wood	Plastic	Brass	Aluminum	Mild Steel
1/2" – 7/8"	500	500	600	600	600	500
1" – 1-7/8"	400	400	500	500	500	400
2" – 2-7/8"	300	300	400	400	400	300
3" – 3-7/8"	200	200	300	300	300	200
4" – 5"	100	100	200	200	200	100

Rosette Cutters	Soft Wood	Hard Wood	Plastic	Brass	Aluminum	Mild Steel
Carbide Insert Type	350	250	/	/	/	/
One-Piece Type	1800	500	/	/	/	/

Tenon/Plug Cutters	Soft Wood	Hard Wood	Plastic	Brass	Aluminum	Mild Steel
3/8" – 1/2"	1200	1000	/	/	/	/
5/8" – 1"	800	600	/	/	/	/

Figure 31. Drill bit speed chart.



Milling Speed

Closely follow the proper cutting speed—with a reasonable feed speed—to reduce undue strain on all moving parts and increase operator safety.

Prior to machining, you need to determine the best speed to cut your workpiece, and then set that speed on the machine.

To determine the needed speed for milling:

1. Use the table in **Figure 32** to determine the cutting speed required for the material of your workpiece.

Cutting Speeds for High Speed Steel (HSS) Cutting Tools	
Workpiece Material	Cutting Speed (SFM)
Aluminum & alloys	300
Brass & Bronze	150
Copper	100
Cast Iron, soft	80
Cast Iron, hard	50
Mild Steel	90
Cast Steel	80
Alloy Steel, hard	40
Tool Steel	50
Stainless Steel	60
Titanium	50
Plastics	300-800
Wood	300-500

Note: For carbide cutting tools, double the cutting speed. These values are a guideline only. Refer to the *MACHINERY'S HANDBOOK* for more detailed information.

Figure 32. Cutting speed table for HSS cutting tools.

2. Measure the diameter of your cutting tool in inches.

3. Use the formula in **Figure 33** to determine the needed speed for your operation:

$$\frac{\text{Cutting Speed (SFM)} \times 4}{\text{Tool Diameter (in inches)}} = \text{RPM}$$

Figure 33. Speed formula for milling.

Note: Always round to the closest RPM given on the spindle speed chart.

Example 1

You have a piece of aluminum stock, and you are using a ½" diameter HSS cutting tool.

Step 1:

$$300 \text{ (SFM from chart)} \times 4 = 1200$$

Step 2:

$$1200 / .5" \text{ (Diameter of cutting tool)} = 2400 \text{ RPM}$$

Result:

The best speed for this workpiece is 2400 RPM.

Example 2

You have a piece of stainless steel, and you are using a 1" diameter carbide cutting tool.

Step 1:

$$60 \text{ (SFM from chart)} \times 2 \text{ (for carbide tool)} = 120$$

Step 2:

$$120 \text{ (determined SFM)} \times 4 = 480$$

Step 3:

$$480 / 1" \text{ (Diameter of cutting tool)} = 480 \text{ RPM}$$

Result:

The best speed for this workpiece is 480 RPM.



SECTION 5: ACCESSORIES

G2500—20-PC Regular Sanding Drum Set

This kit consists of 5 drums in popular $\frac{1}{2}$ " x $\frac{1}{2}$ ", $\frac{3}{4}$ " x 1", 1" x 1", $1\frac{1}{2}$ " x $1\frac{1}{2}$ ", and 2" x $1\frac{1}{2}$ " sizes. Comes with 50, 80 and 120 grit sizes for each drum.



Figure 34. Model G2500 20-PC Sanding Drum Set.

G8865—Cobalt Alloy Drill Bits 13-PC. Set

G8866—Steelex® Cobalt Alloy Drill Set 21-PC

G8867—Steelex® Cobalt Alloy Drill Set 29-PC

Cobalt Alloy bits will retain their edge sharpness longer than normal HSS bits, resulting in a significant saving of time and money in the workshop. Includes a heavy-gauge steel index case for storing. G8865: $\frac{1}{16}$ " - $\frac{1}{4}$ "; G8866: $\frac{1}{16}$ " - $\frac{3}{8}$ "; G8867: $\frac{1}{16}$ " - $\frac{1}{2}$ ".



Figure 35. Model G8865 13-PC Alloy Drill Bits.

H5685—4" Rotary Table

The perfect rotary table for all you model makers and those doing smaller precision work. Comes with clamping kit.



Figure 36. H5685 4" Rotary Table.

G3640—Power Twist® V-Belt $\frac{1}{2}$ " x 48"

Smooth running with less vibration and noise than solid belts. The Power Twist® V-belts can be customized in minutes to any size—just add or remove sections to fit your needs. Size: $\frac{1}{2}$ " x 48"; replaces all "A" sized V-belts. Requires two Power Twist® V-belts to replace the stock V-belt on your Model G0517. Well worth it. A very nice upgrade!

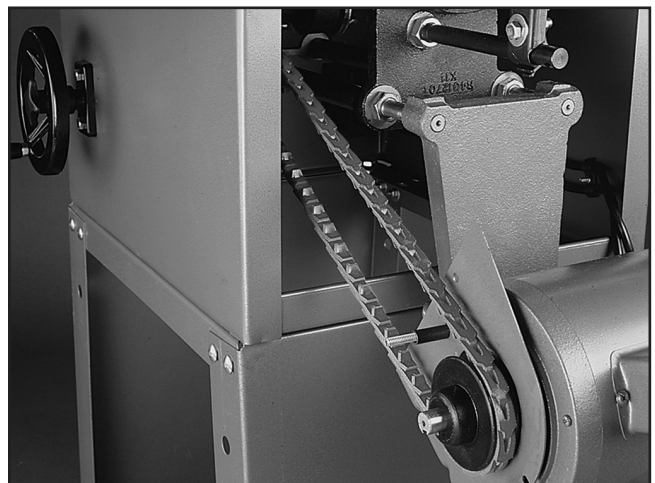

Figure 37. G3640 Power Twist® V-Belt installed.

Call 1-800-523-4777 To Order



G9765—9-PC. Ball End Mill Set

Features 2 flute ball nose end mills. Includes the following sizes: 1/8", 3/16", 1/4", 5/16", 3/8", 7/16", 1/2", 5/8" and 3/4".

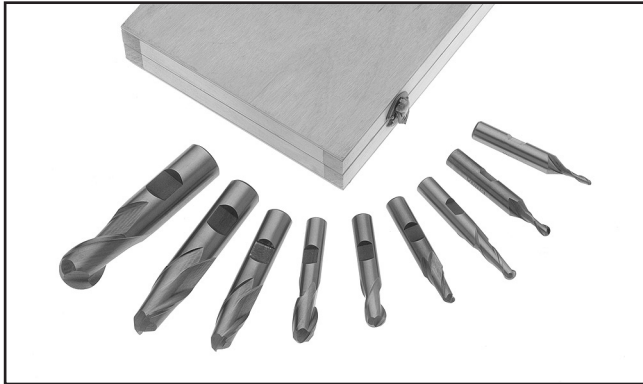

Figure 38. G9765 9 PC. Ball End Mill Set.

H3022—Measurement Tool Set

Includes magnetic base, 1" dial indicator (.001"), and 6" dial caliper (.001"). The extremely low price has made this a very popular seller!

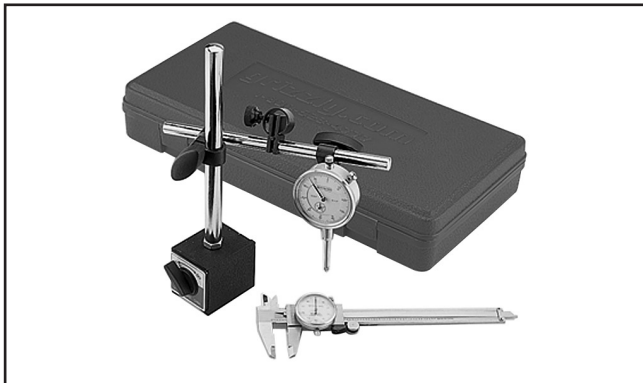

Figure 39. H3022 Measurement Tool Set.

G2861—2 1/2" Face Mill w/R-8 Arbor

G2863—MT#3 Arbor for Face Mill

This 2 1/2" Face Mill accepts four carbide inserts. The Model G2863 must be purchased with this face mill for use on this mill/drill.



Figure 40. G2861 Face mill.

G5608—MT#3, 3/16" Shank End Mill Holder

G5609—MT#3, 3/8" Shank End Mill Holder

G0510—MT#3, 1/2" Shank End Mill Holder

G0511—MT#3, 5/8" Shank End Mill Holder

G0512—MT#3, 3/4" Shank End Mill Holder

All the above use an M12-1.75 drawbar.



Figure 41. End mill holder.

G9760—20-PC. 2 & 4 Flute TiN End Mill Set.

Includes 2 & 4 flute styles of these sizes: 3/16", 1/4", 5/16", 3/8", 7/16", 1/2", 9/16", 5/8", 3/8", 11/16", and 3/4".



Figure 42. G9760 20-PC End Mill Set.

G1076—52-PC. Clamping Kit

This clamping kit includes 24 studs, 6 step block pairs, 6 T-nuts, 6 flange nuts, 4 coupling nuts, and 6 end hold-downs. The rack is slotted so it can be mounted close to the machine for easy access.

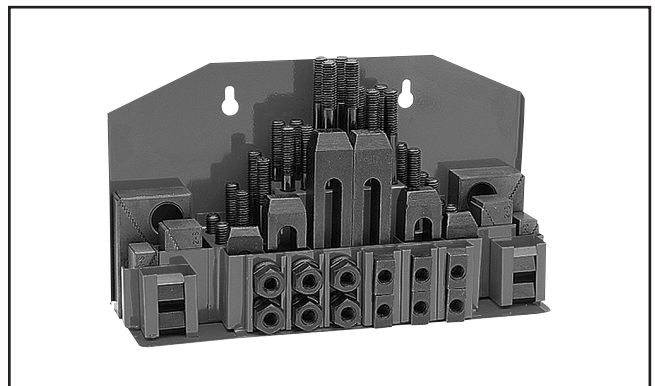
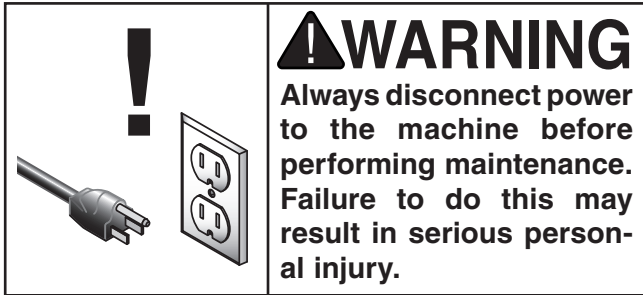

Figure 43. G1076 52-PC. Clamping Kit.



SECTION 6: MAINTENANCE



Schedule

For optimum performance from your machine, follow this maintenance schedule and refer to any specific instructions given in this section.

Daily Check:

- Mill/drill is completely powered down at the end of use.
- Excess cutting fluids and chips have been removed and unpainted surfaces are dry and protected.
- Loose mounting bolts.
- Mill/drill is clean and lubricated.
- Worn or damaged wires.
- Any other unsafe condition.

Monthly Check:

- Gibs are adjusted properly.

Unpainted Cast Iron

Protect the unpainted cast iron surfaces on the table by removing vises and fixtures daily and by wiping the table clean after every use—this ensures moisture does not remain on bare metal surfaces.

Keep tables rust-free with regular applications of products like G96® Gun Treatment or Boeshield® T-9. See below for Grizzly model numbers:

G2871—Boeshield® T-9 12 oz Spray

G2870—Boeshield® T-9 4 oz Spray

H3788—G96® Gun Treatment 12 oz Spray

H3789—G96® Gun Treatment 4.5 oz Spray

Lubrication

Ways

Place two to three drops of ISO 68 or SAE 20W non-detergent oil or similar lubricant directly on the ways of the cross feed and longitudinal table.

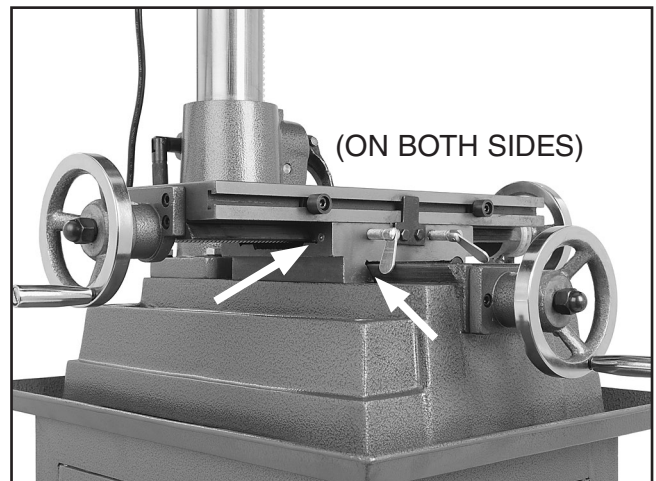

Figure 44. Cross feed and longitudinal ways.

Rack & Pinion

Brush a small amount of multi-purpose grease on the column rack near the pinion. Move the column up and down to distribute the grease.



Figure 45. Rack & pinion greasing location.



Oil Fittings

Oil fittings are located on the tops of each handwheel and on each side of the base. Lubricate these fittings with ISO 68 or SAE 20W oil by depressing the ball with an oil can nozzle and squirting once or twice.

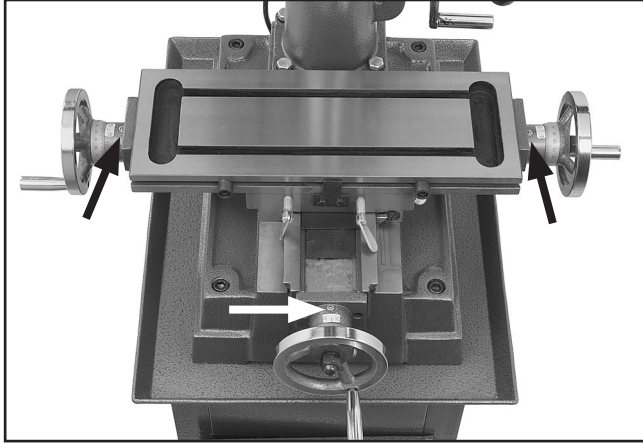

Figure 46. Handwheel oil fittings.

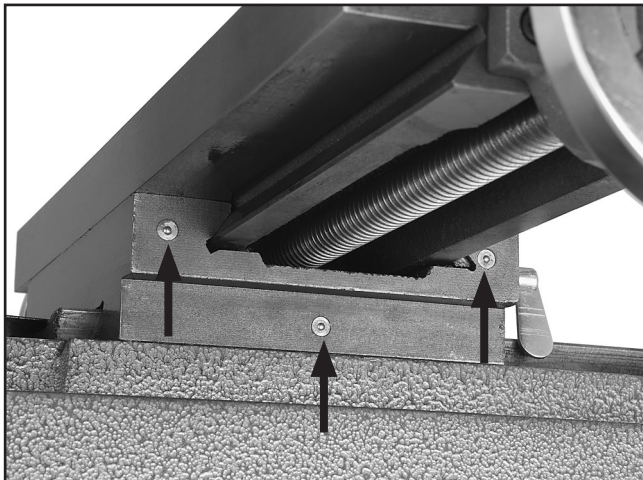

Figure 47. Oil fittings on left-side of table.

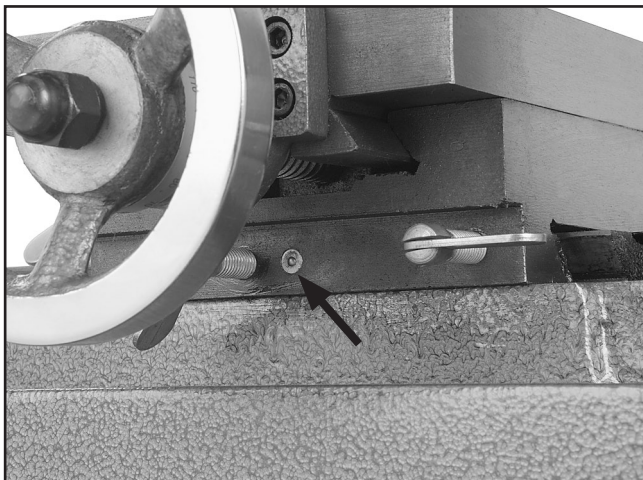

Figure 48. Oil fittings on right-side of table.

Adjusting Gibs

The gibs control play in the longitudinal and cross feed table movement; they are pre-adjusted at the factory and typically need no adjustments until the machine is well used. If table movement is too tight, make sure the locks are fully released. Next, make sure the bedways are thoroughly cleaned of rust preventative and lubricated with oil.

Both the longitudinal table and the cross feed table have gib adjustment screws (see **Figure 49** for the location). Turn the gib adjustment screw clockwise to tighten the gib or turn counterclockwise to loosen the gib.

To adjust the gibs:

1. Turn the gib screw one full turn in the necessary direction for tightening or loosening.
2. Test the gib tension by turning the handwheel and moving the table back and forth. Repeat **Step 1** as necessary.

NOTICE

When adjusting gibs, the goal is to remove unnecessary sloppiness without causing the slides to bind. Loose gibs may cause poor finishes on the workpiece and may cause undue wear on the slide. Over-tightened gibs may cause premature wear.

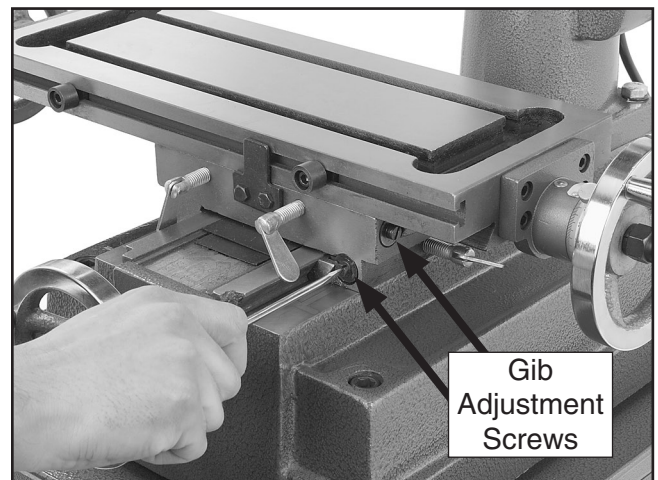

Figure 49. Gib adjustment.



SECTION 7: SERVICE

About Service

This section is provided for your convenience—it is not a substitute for the Grizzly Service Department. If you need help troubleshooting, you need replacement parts, or you are unsure of how to perform the procedures in this section, then feel free to call our Technical Support at (570) 546-9663.

Troubleshooting

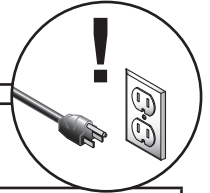

Motor & Electrical

Symptom	Possible Cause	Possible Solution
Machine does not start or a breaker trips.	<ol style="list-style-type: none"> 1. Plug or receptacle is at fault or wired incorrectly. 2. Cable or wiring is open or has high resistance. 3. Power supply is faulty, or is switched OFF. 4. Safety switch key is at fault. 5. ON/OFF switch at fault. 6. Motor connection is wired incorrectly. 7. Motor is at fault. 	<ol style="list-style-type: none"> 1. Test power plug and receptacle for good contact and correct wiring. 2. Troubleshoot wires for internal or external breaks, check for disconnected or corroded connections and repair or replace wiring, as necessary. 3. Make sure all hot lines and grounds are operational and have correct voltage on all legs. 4. Install or replace safety key, or replace switch assembly. 5. Replace faulty switch. 6. Correct motor wiring (see Page 28). 7. Test, repair or replace motor.
Machine stalls or is under-powered.	<ol style="list-style-type: none"> 1. Incorrect spindle speed or feed rate. 2. Machine is undersized for the task. 3. Bit or cutter is too large for machine. 4. Belts are slipping. 5. Plug or receptacle is at fault. 6. Pulley is slipping on shaft. 7. Low power supply voltage. 8. Motor bearings are at fault. 9. Motor has overheated. 10. Motor connection is wired incorrectly. 11. Motor is at fault. 	<ol style="list-style-type: none"> 1. Decrease spindle speed or feed rate. 2. Use smaller drill bits/cutters and reduce the feed rate and spindle speed. 3. Use a smaller bit. 4. Replace bad belts, align pulleys, and re-tension. 5. Test power plug and receptacle for good contact and correct wiring. 6. Replace loose pulley and shaft. 7. Make sure hot lines and grounds are operational w/ correct voltage. 8. Rotate motor shaft for noisy or burnt bearings, repair/replace as required. 9. Clean dust off motor, let it cool, and reduce workload on machine. 10. Correct motor wiring (see Page 28). 11. Test, repair or replace motor.



Symptom	Possible Cause	Possible Solution
Machine vibrates excessively or is unusually noisy.	<ol style="list-style-type: none"> 1. Motor fan is rubbing on fan cover. 2. Motor or component is loose. 3. Belt is slapping belt cover. 4. V-belt is worn. 5. Pulley is loose. 6. Machine is incorrectly mounted to the stand, stand is incorrectly mounted to the floor, or the stand is uneven. 7. Chuck or cutter is at fault. 8. Motor bearings are at fault. 9. Spindle bearings at fault. 	<ol style="list-style-type: none"> 1. Replace/repair dented fan cover, and replace loose or damaged fan. 2. Replace component fasteners and re-tighten with thread locking fluid. 3. Replace, realign, or re-tension belt (refer to Page 18). 4. Replace belt. 5. Remove pulley, replace with key as required, and re-install securely. 6. Make sure the mounting hardware is tight; place shims under machine. 7. Replace out-of-round chuck, replace or sharpen cutter, use appropriate feed rate and cutting RPM. 8. Check bearings, replace motor or bearings as required. 9. Replace bearings.

Mill/Drill Operations

Symptom	Possible Cause	Possible Solution
Drilling stops, but the motor still operates.	<ol style="list-style-type: none"> 1. The belt is loose, worn, or broken. 2. Bit slips in chuck. 	<ol style="list-style-type: none"> 1. Replace or adjust the belt. 2. Tighten bit; inspect bit for burrs or other obstructions that might interfere with clamping surface.
The chuck wobbles or is loose on the spindle shaft.	<ol style="list-style-type: none"> 1. Foreign material is stuck between the chuck-to-spindle mating surface. 2. Damaged chuck. 	<ol style="list-style-type: none"> 1. Remove the chuck, clean, and de-burr the tapered chuck and spindle mating surfaces, then reassemble. 2. Replace.
The spindle does not retract completely in the uppermost position or it binds.	<ol style="list-style-type: none"> 1. The quill shaft is gummy with sawdust and oil. 2. The quill lock is locked or not fully released. 3. The feed shaft return spring is weak. 	<ol style="list-style-type: none"> 1. Clean shaft and lubricate with a light coat of oil. 2. Fully release the quill lock. 3. Increase the feed shaft return spring tension.
The quill has excessive deflection.	<ol style="list-style-type: none"> 1. The quill bearings are worn or damaged. 2. The quill shaft is at fault. 	<ol style="list-style-type: none"> 1. Replace the bearings. 2. Replace the quill shaft.
Drill bit wobbles, holes are oversized.	<ol style="list-style-type: none"> 1. Drill bit installed incorrectly. 	<ol style="list-style-type: none"> 1. Remove drill bit and reinstall.



Electrical Components



Figure 50. Power switch assembly.

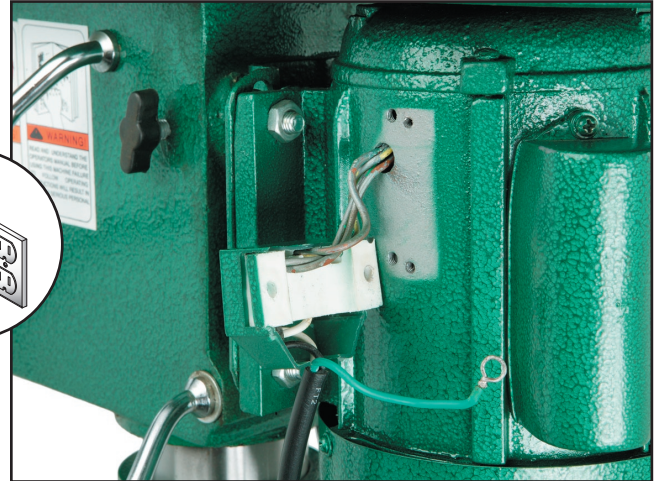
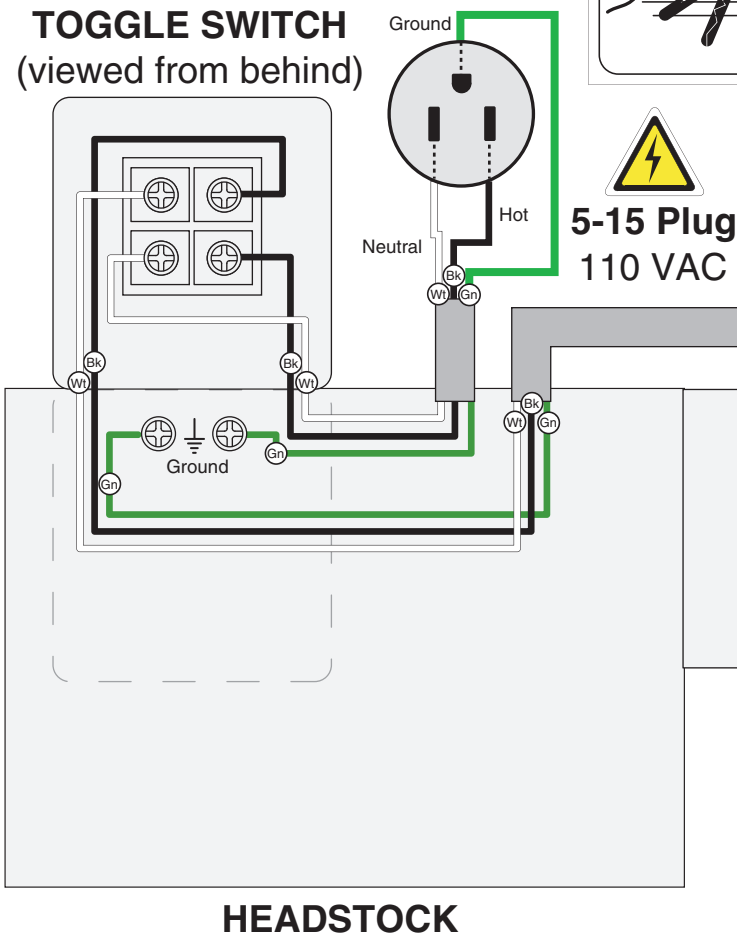

Figure 51. Motor wiring inside junction box.

Wiring Diagram



TOGGLE SWITCH
(viewed from behind)



MODEL G0517

COLOR KEY	
BLACK	Bk
WHITE	Wt
GREEN	Gn
YELLOW	Yl
BROWN	Br

MOTOR

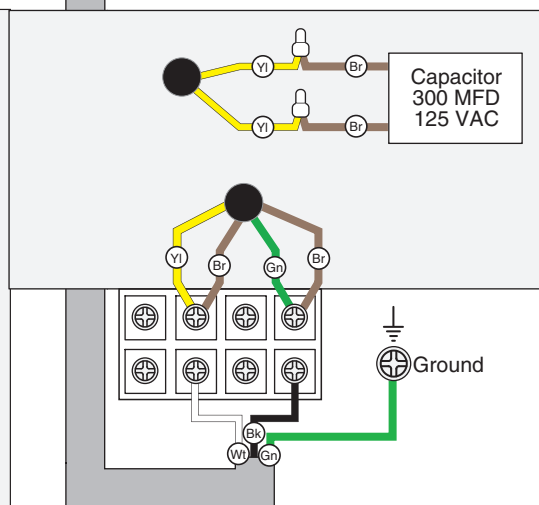

HEADSTOCK



Stand/Base Parts Breakdown

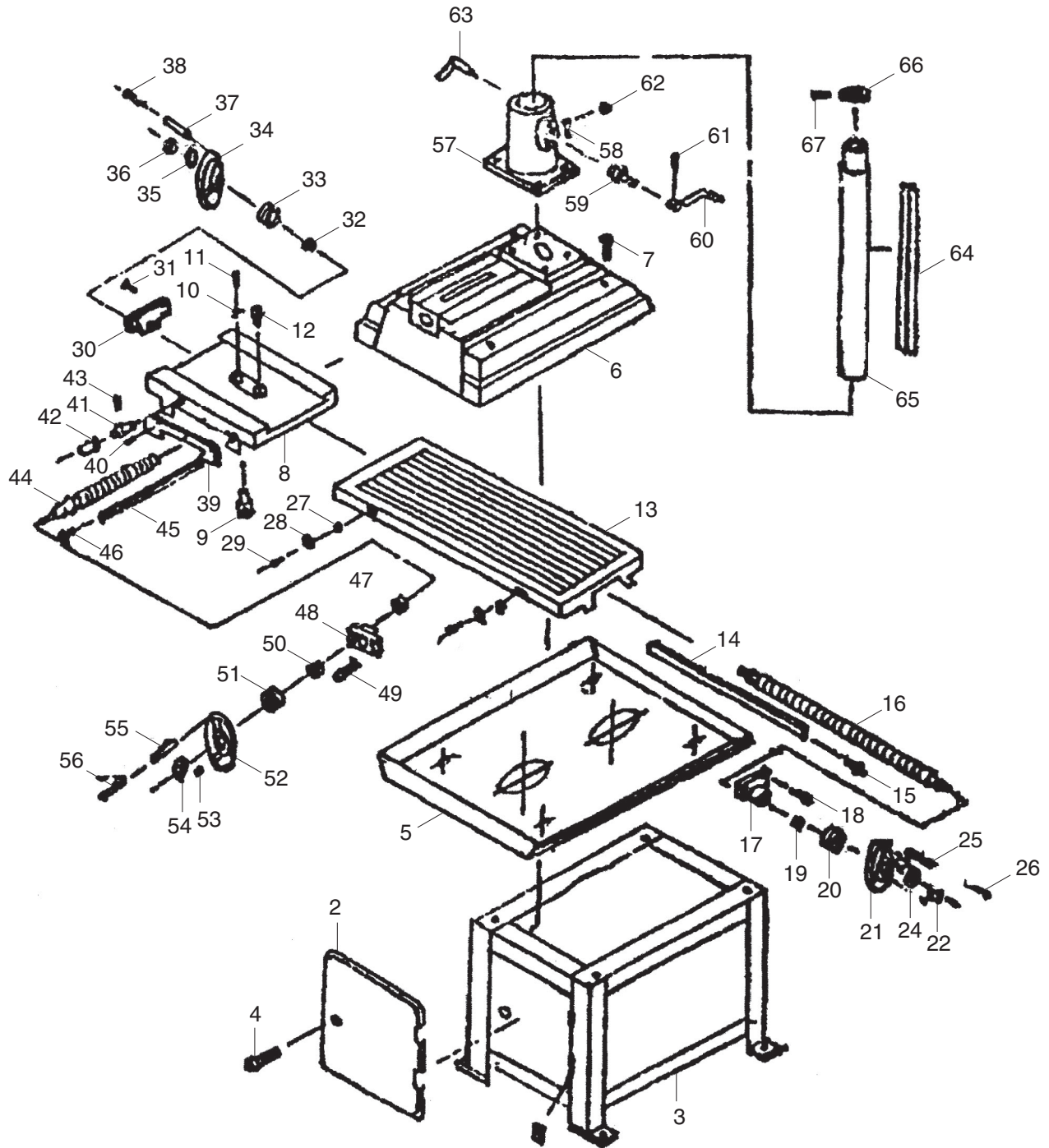

Stand/Base Parts List

REF	PART #	DESCRIPTION
1	P0517001	BASE
2	P0517002	DOOR
3	P0517003	HINGE
4	P0517004	KNURLED THUMB SCREW M6-1 X 20
5	P0517005	OIL PLATE
6	P0517006	BASE
7	P0517007	CAP SCREW M12-1.75 X 150
8	P0517008	SADDLE
9	P0517009	NUT TR20 X 4-9H
10	PW01M	FLAT WASHER 8MM
11	PS16M	PHLP HD SCR M8-1.25 x 16
12	P0517012	NUT TR20 X 4-9H
13	P0517013	TABLE
14	P0517014	LONG BEVEL IRON
15	P0517015	ADJUST SCREW M8-69
16	P0517016	LONGITUDINAL LEAD SCREW
17	P0517017	SUPPORT
18	PSB01M	CAP SCREW M6-1 X 16
19	P51102	THRUST BEARING 51102
20	P0517020	SCALE RING
21	P0517021	HANDWHEEL
22	PK54M	KEY 3 X 3 X 19
23	PLW05M	LOCK WASHER 12MM
24	PN43M	ACORN NUT M12-1.75
25	P0517055	HANDLE COLLAR
26	P0517056	HANDLE
27	P0517027	SCREW BRACKET
28	P0517028	DOG
29	PSB27M	CAP SCREW M6-1 X 14
30	P0517030	SUPPORT
31	PSB01M	CAP SCREW M6-1 X 16
32	P51102	THRUST BEARING 51102
33	P0517033	SCALE RING
34	P0517034	HANDWHEEL

REF	PART #	DESCRIPTION
35	PW06M	FLAT WASHER 12MM
36	PN43M	ACORN NUT M12-1.75
37	P0517055	HANDLE COLLAR
38	P0517056	HANDLE
39	P0517039	COVER
40	PB02M	HEX BOLT M6-1 X 12
41	P0517041	THUMB SCREW M10-1.5 X 30
42	P0517042	THUMB HANDLE
43	P0517043	PIN
44	P0517044	CROSSFEED LEAD SCREW
45	P0517045	SHORT BEVEL IRON
46	P0517046	ADJUST SCREW M8-69
47	P51102	THRUST BEARING 51102
48	P0517048	SUPPORT
49	PSB01M	CAP SCREW M6-1 X 16
50	P51102	THRUST BEARING 51102
51	P0517051	SCALE RING
52	P0517052	HANDWHEEL
53	PK54M	KEY 3 X 3 X 19
54	PN43M	ACORN NUT M12-1.75
55	P0517055	HANDLE COLLAR
56	P0517056	HANDLE
57	P0517057	SUPPORT (REST)
58	PB24M	HEX BOLT M12-1.75 X 45
59	P0517059	WORM GEAR
60	P0517060	HANDLE
61	P0517061	PIN
62	P0517062	GEAR
63	P0517063	CLAMP HANDLE
64	P0517064	RACK
65	P0517065	COLUMN
66	P0517066	DUST COVER
67	PSS14M	SET SCREW M8-1.25 X 12

WARNING

Safety labels warn about machine hazards and ways to prevent injury. The owner of this machine **MUST** maintain the original location and readability of the labels on the machine. If any label is removed or becomes unreadable, **REPLACE** that label before using the machine again. Contact Grizzly at (800) 523-4777 or www.grizzly.com to order new labels.



Headstock Parts Breakdown

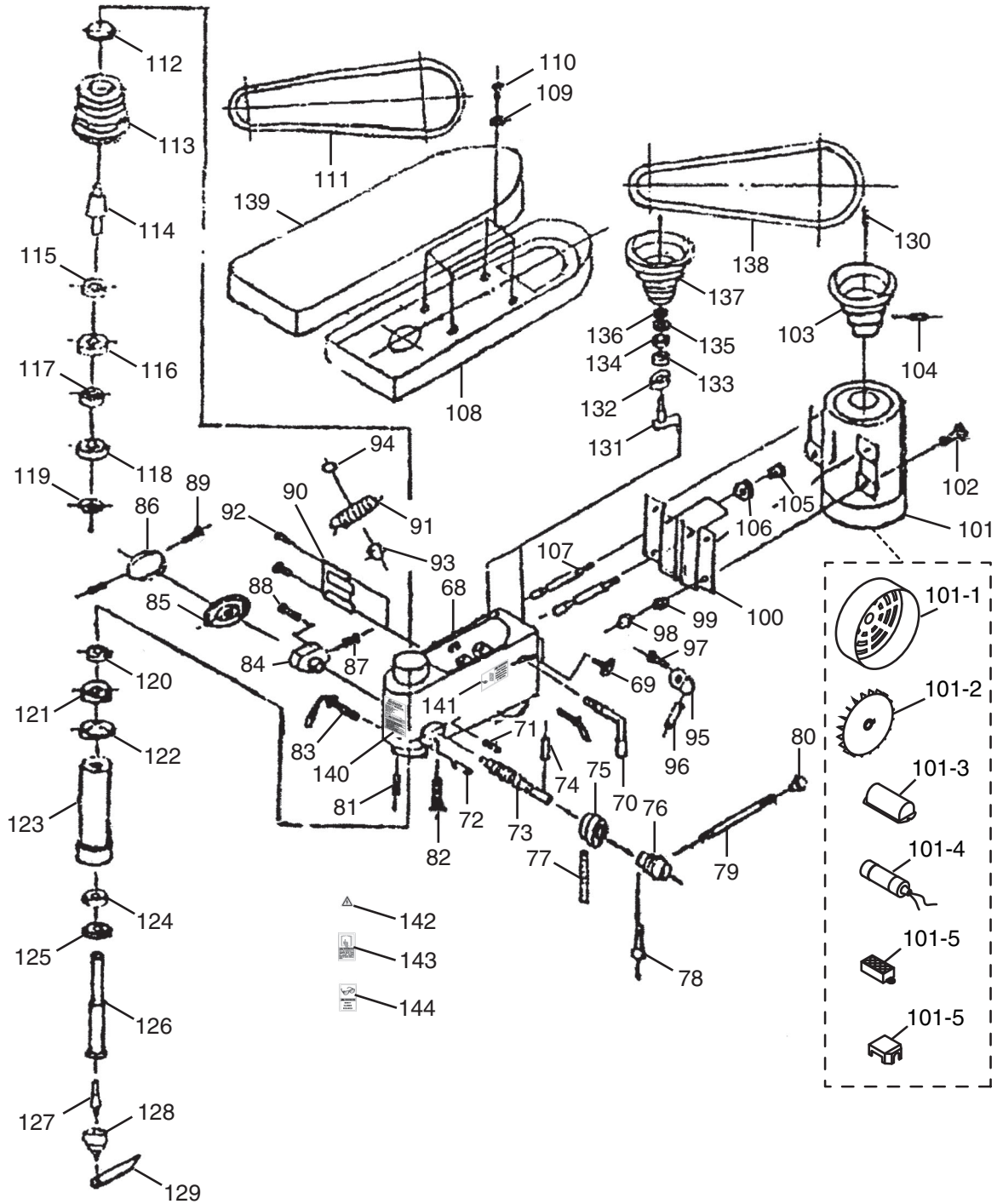

Headstock Parts List

REF	PART #	DESCRIPTION
68	P0517068	BODY
69	P0517069	KNOB M8-1.25 X 25
70	P0517070	SHIFTER BAR
71	P0517071	PIN
72	P0517072	PIN
73	P0517073	FEED SHAFT
74	P0517074	PIN
75	P0517075	SCALE RING
76	P0517076	HANDLE BODY
77	P0517077	SCALE
78	P0517078	KNOB M8-1.25 X 16
79	P0517079	HANDLE BAR
80	P0517080	BALL KNOB M12-1.75
81	P0517081	SPECIAL SET SCREW M6-1 X 20
82	P0517082	FLAT HD DOG PT SCREW M6-1 X 22
83	P0517083	CLAMP HANDLE
84	P0517084	SPRING HANDLE
85	P0517085	SPRING PLATE
86	P0517086	SPRING CAP
87	PSB02M	CAP SCREW M6-1 X 20
88	PSB01M	CAP SCREW M6-1 X 16
89	PS17M	PHLP HD SCR M4-.7 x 6
90	P0517090	SWITCH
91	P0517091	WIRE
92	PS38M	PHLP HD SCR M4-.7 X 10
93	P0517093	RUBBER BUSHING
94	P0517094	WIRE CLIP
95	P0517095	SHIFT
96	P0517096	PIN
97	PSB47M	CAP SCREW M10-1.5 X 40
98	PN03M	HEX NUT M8-1.25
99	PW01M	FLAT WASHER 8MM
100	P0517100	MOTOR BASE
101	P0517101	MOTOR
101-1	P0517101-1	FAN COVER
101-2	P0517101-2	MOTOR FAN
101-3	P0517101-3	CAPACITOR COVER
101-4	P0517101-4	CAPACITOR 300MFD 125VAC
101-5	P0517101-5	TERMINAL BLOCK
101-6	P0517101-6	TERMINAL BLOCK COVER
102	PB07M	HEX BOLT M8-1.25 X 25
103	P0517103	MOTOR PULLEY

REF	PART #	DESCRIPTION
104	PSS23M	SET SCREW M4-.7 X 10
105	PN09M	HEX NUT M12-1.75
106	PN09M	HEX NUT M12-1.75
107	P0517107	SLIDE BAR
108	P0517139	PULLEY COVER
109	PW03M	FLAT WASHER 6MM
110	PSB26M	CAP SCREW M6-1 X 12
111	P0517111	V-BELT A-27 4L270
112	P0517112	SPANNER NUT
113	P0517113	SPINDLE PULLEY
114	P0517114	SPRING SLEEVE
115	PR24M	INT RETAINING RING 42MM
116	P6204	BALL BEARING 6204
117	P0517117	COLLAR
118	P6204	BALL BEARING 6204
119	PR25M	INT RETAINING RING 47MM
120	P0517120	SPANNER NUT
121	P0517121	BEARING WASHER 17MM
122	P6203	BALL BEARING 6203
123	P0517123	SLEEVE
124	P6205	BALL BEARING 6205
125	P0517125	DUST COVER
126	P0517126	SPINDLE
127	P0517127	SPINDLE BAR
128	P0517128	DRILL CHUCK 1-16MM B-16
129	P0517129	WEDGE SHIFTER
130	PK54M	KEY 3 X 3 X 19
131	P0517131	CENTER PULLEY SHAFT
132	P6201	BALL BEARING 6201
133	P0517133	COLLAR
134	P6201	BALL BEARING 6201
135	PR29M	INT RETAINING RING 32MM
136	PR03M	EXT RETAINING RING 12MM
137	P0517137	CENTER PULLEY
138	PVA31	V-BELT A-31 4L310
139	P0517139	PULLEY COVER
140	P0517140	MACHINE ID LABEL
141	P0517141	UNPLUG POWER LABEL
142	PLABEL-14	ELECTRICITY LABEL
143	PLABEL-12A	READ MANUAL LABEL
144	PLABEL-11	SAFETY GLASSES LABEL

WARNING

Safety labels warn about machine hazards and ways to prevent injury. The owner of this machine **MUST** maintain the original location and readability of the labels on the machine. If any label is removed or becomes unreadable, **REPLACE** that label before using the machine again. Contact Grizzly at (800) 523-4777 or www.grizzly.com to order new labels.



WARRANTY AND RETURNS

Grizzly Industrial, Inc. warrants every product it sells for a period of **1 year** to the original purchaser from the date of purchase. This warranty does not apply to defects due directly or indirectly to misuse, abuse, negligence, accidents, repairs or alterations or lack of maintenance. This is Grizzly's sole written warranty and any and all warranties that may be implied by law, including any merchantability or fitness, for any particular purpose, are hereby limited to the duration of this written warranty. We do not warrant or represent that the merchandise complies with the provisions of any law or acts unless the manufacturer so warrants. In no event shall Grizzly's liability under this warranty exceed the purchase price paid for the product and any legal actions brought against Grizzly shall be tried in the State of Washington, County of Whatcom.

We shall in no event be liable for death, injuries to persons or property or for incidental, contingent, special, or consequential damages arising from the use of our products.

To take advantage of this warranty, contact us by mail or phone and give us all the details. We will then issue you a "Return Number," which must be clearly posted on the outside as well as the inside of the carton. We will not accept any item back without this number. Proof of purchase must accompany the merchandise.

The manufacturers reserve the right to change specifications at any time because they constantly strive to achieve better quality equipment. We make every effort to ensure that our products meet high quality and durability standards and we hope you never need to use this warranty.

Please feel free to write or call us if you have any questions about the machine or the manual.

Thank you again for your business and continued support. We hope to serve you again soon.





WARRANTY CARD

Name _____
 Street _____
 City _____ State _____ Zip _____
 Phone # _____ Email _____ Invoice # _____
 Model # _____ Order # _____ Serial # _____

The following information is given on a voluntary basis. It will be used for marketing purposes to help us develop better products and services. **Of course, all information is strictly confidential.**

1. How did you learn about us?

Advertisement Friend Catalog
 Card Deck Website Other:

2. Which of the following magazines do you subscribe to?

<input type="checkbox"/> Cabinet Maker	<input type="checkbox"/> Popular Mechanics	<input type="checkbox"/> Today's Homeowner
<input type="checkbox"/> Family Handyman	<input type="checkbox"/> Popular Science	<input type="checkbox"/> Wood
<input type="checkbox"/> Hand Loader	<input type="checkbox"/> Popular Woodworking	<input type="checkbox"/> Wooden Boat
<input type="checkbox"/> Handy	<input type="checkbox"/> Practical Homeowner	<input type="checkbox"/> Woodshop News
<input type="checkbox"/> Home Shop Machinist	<input type="checkbox"/> Precision Shooter	<input type="checkbox"/> Woodsmith
<input type="checkbox"/> Journal of Light Cont.	<input type="checkbox"/> Projects in Metal	<input type="checkbox"/> Woodwork
<input type="checkbox"/> Live Steam	<input type="checkbox"/> RC Modeler	<input type="checkbox"/> Woodworker West
<input type="checkbox"/> Model Airplane News	<input type="checkbox"/> Rifle	<input type="checkbox"/> Woodworker's Journal
<input type="checkbox"/> Modeltec	<input type="checkbox"/> Shop Notes	<input type="checkbox"/> Other:
<input type="checkbox"/> Old House Journal	<input type="checkbox"/> Shotgun News	

3. What is your annual household income?

\$20,000-\$29,000 \$30,000-\$39,000 \$40,000-\$49,000
 \$50,000-\$59,000 \$60,000-\$69,000 \$70,000+

4. What is your age group?

20-29 30-39 40-49
 50-59 60-69 70+

5. How long have you been a woodworker/metalworker?

0-2 Years 2-8 Years 8-20 Years 20+ Years

6. How many of your machines or tools are Grizzly?

0-2 3-5 6-9 10+

7. Do you think your machine represents a good value?

Yes No

8. Would you recommend Grizzly Industrial to a friend?

Yes No

9. Would you allow us to use your name as a reference for Grizzly customers in your area?

Note: *We never use names more than 3 times.* Yes No

10. Comments: _____

CUT ALONG DOTTED LINE

FOLD ALONG DOTTED LINE



Place
Stamp
Here



GRIZZLY INDUSTRIAL, INC.
P.O. BOX 2069
BELLINGHAM, WA 98227-2069



FOLD ALONG DOTTED LINE

Send a Grizzly Catalog to a friend:

Name _____
Street _____
City _____ State _____ Zip _____

TAPE ALONG EDGES--PLEASE DO NOT STAPLE

grizzly.com

TOOL WEBSITE

Buy Direct and Save with Grizzly®: Trusted, Proven and a Great Value!

*Visit Our Website Today And Discover Why
Grizzly® Is The Industry Leader!*

- SECURE ORDERING
- ORDERS SHIPPED WITHIN 24 HOURS
- E-MAIL RESPONSE WITHIN ONE HOUR

-OR-

Call Today For A **FREE**
Full Color Catalog

1-800-523-4777

