

READ THIS FIRST



Model G0514X

*****IMPORTANT UPDATE*****

For Machines Mfd. Since 03/25
and Manual Revised 02/22

For questions or help with this product contact Tech Support at (570) 546-9663 or techsupport@grizzly.com

The following changes were recently made since the owner's manual was printed:

- Parts have changed.
- **Inventory** and **Assembly** have changed.

Aside from this information, all other content in the owner's manual applies and **MUST** be read and understood for your own safety. **IMPORTANT: Keep this update with the owner's manual for future reference.**

For questions or help, contact our Tech Support at (570) 546-9663 or techsupport@grizzly.com.

Revised Parts

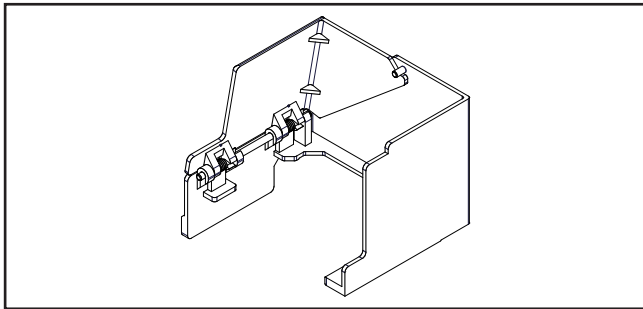

REF	PART #	DESCRIPTION
183	P0514X183	DUST DEFLECTOR

Revised Inventory

Inventory (Figure 1)	Qty
I. Dust Deflector.....	1



Figure 1. Revised inventory.

New Table Assembly Step

7. Set table tilt to 0°, and install dust deflector under table so it rests on door and frame (see **Figure 2**). Ensure (2) magnets on face of deflector attach securely to bandsaw frame.

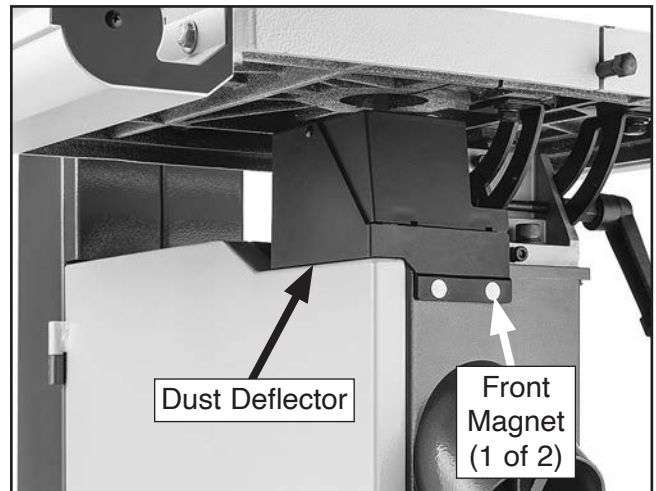

Figure 2. Example of dust deflector installed.



COPYRIGHT © FEBRUARY, 2025 BY GRIZZLY INDUSTRIAL, INC.
WARNING: NO PORTION OF THIS MANUAL MAY BE REPRODUCED IN ANY SHAPE OR FORM WITHOUT THE WRITTEN APPROVAL OF GRIZZLY INDUSTRIAL, INC.
 #SG23491 PRINTED IN TAIWAN

Grizzly *Industrial, Inc.*®

MODEL G0514X, G0514X2, G0514X2B, & G0514X3 EXTREME SERIES BANDSAW OWNER'S MANUAL (For models manufactured since 2/12)



COPYRIGHT © JANUARY, 2006 BY GRIZZLY INDUSTRIAL, INC., REVISED FEBRUARY, 2022 (JL)
**WARNING: NO PORTION OF THIS MANUAL MAY BE REPRODUCED IN ANY SHAPE
OR FORM WITHOUT THE WRITTEN APPROVAL OF GRIZZLY INDUSTRIAL, INC.**
#EWTR7787 PRINTED IN TAIWAN

V4.02.22

*****Keep for Future Reference*****



WARNING!

This manual provides critical safety instructions on the proper setup, operation, maintenance, and service of this machine/tool. Save this document, refer to it often, and use it to instruct other operators.

Failure to read, understand and follow the instructions in this manual may result in fire or serious personal injury—including amputation, electrocution, or death.

The owner of this machine/tool is solely responsible for its safe use. This responsibility includes but is not limited to proper installation in a safe environment, personnel training and usage authorization, proper inspection and maintenance, manual availability and comprehension, application of safety devices, cutting/sanding/grinding tool integrity, and the usage of personal protective equipment.

The manufacturer will not be held liable for injury or property damage from negligence, improper training, machine modifications or misuse.



WARNING!

Some dust created by power sanding, sawing, grinding, drilling, and other construction activities contains chemicals known to the State of California to cause cancer, birth defects or other reproductive harm. Some examples of these chemicals are:

- **Lead from lead-based paints.**
- **Crystalline silica from bricks, cement and other masonry products.**
- **Arsenic and chromium from chemically-treated lumber.**

Your risk from these exposures varies, depending on how often you do this type of work. To reduce your exposure to these chemicals: Work in a well ventilated area, and work with approved safety equipment, such as those dust masks that are specially designed to filter out microscopic particles.

Table of Contents

INTRODUCTION	2	Ripping.....	43
Contact Info.....	2	Crosscutting.....	44
Manual Accuracy.....	2	Resawing.....	44
Identification (G0514X).....	3	Cutting Curves.....	45
Identification		Stacked Cuts.....	46
(G0514X2/G0514X2B/G0514X3).....	4	Blade Speed.....	46
Machine Data.....	5	Blade Information.....	47
SECTION 1: SAFETY	7	Blade Changes.....	49
Safety Instructions for Machinery.....	7	SECTION 5: ACCESSORIES	50
Additional Safety for Bandsaws.....	9	SECTION 6: MAINTENANCE	52
SECTION 2: POWER SUPPLY	10	Schedule.....	52
G0514X3 440V Conversion.....	13	Cleaning.....	52
SECTION 3: SETUP	14	Unpainted Cast Iron.....	52
Needed for Setup.....	14	Brushes.....	52
G0514X Inventory.....	15	Lubrication.....	52
G0514X2 & G0514X3 Inventory.....	16	SECTION 7: SERVICE	55
G0514X2B.....	17	Troubleshooting.....	55
Hardware Recognition Chart.....	18	Checking V-Belt.....	59
Clean Up.....	19	Tensioning V-Belt.....	59
Site Considerations.....	19	Replacing V-Belt.....	60
Moving & Placing Base Unit.....	20	Blade Lead.....	61
Mounting.....	21	Adjusting Wheel Brush.....	62
Assembly.....	21	Adjusting Tension Lever.....	62
Blade Tracking.....	23	Adjusting Guide Post Travel.....	63
Positive Stop.....	25	Aligning Wheels.....	65
Dust Collection.....	26	SECTION 8: WIRING	68
Installing Fence.....	26	Wiring Safety Instructions.....	68
(G0514X, -X2, X3).....	26	G0514X Wiring Diagram.....	69
Installing Fence (G0514X2B).....	28	G0514X2 Wiring Diagram.....	70
Installing Foot Brake (G0514X2, -X3).....	28	G0514X2B Wiring Diagram.....	71
G0514X, -X2, & X2B Power Connection.....	29	G0514X3 Wiring Diagram.....	72
G0514X3 Power Connection.....	29	SECTION 9: PARTS	73
Test Run.....	30	G0514X Main.....	73
Tensioning Blade.....	31	G0514X Fence/Guides.....	75
Adjusting Support Bearings.....	32	G0514X2 & G0514X3 Main.....	78
Adjusting Blade Guide Bearings.....	33	G0514X2 & G0514X3 Fence & Guides.....	81
Aligning Table.....	35	G0514X2 & G0514X3 Labels.....	84
Aligning Fence.....	35	G0514X2B Main.....	85
Fence Pointer Calibration.....	36	G0514X2B Fence & Guides.....	87
Miter Gauge.....	36	G0514X2B Labels.....	90
SECTION 4: OPERATIONS	37	WARRANTY & RETURNS	93
Basic Controls.....	37		
Operation Overview.....	39		
Basic Cutting Tips.....	39		
Workpiece Inspection.....	40		
Foot Brake.....	41		
Table Tilt.....	41		
Guide Post.....	42		
Fine Tune Tracking.....	43		

INTRODUCTION

Contact Info

We stand behind our machines! If you have questions or need help, contact us with the information below. Before contacting, make sure you get the **serial number** and **manufacture date** from the machine ID label. This will help us help you faster.

Grizzly Technical Support
1815 W. Battlefield
Springfield, MO 65807
Phone: (570) 546-9663
Email: techsupport@grizzly.com

We want your feedback on this manual. What did you like about it? Where could it be improved? Please take a few minutes to give us feedback.

Grizzly Documentation Manager
P.O. Box 2069
Bellingham, WA 98227-2069
Email: manuals@grizzly.com

Manual Accuracy

We are proud to provide a high-quality owner's manual with your new machine!

We made every effort to be exact with the instructions, specifications, drawings, and photographs in this manual. Sometimes we make mistakes, but our policy of continuous improvement also means that **sometimes the machine you receive is slightly different than shown in the manual.**

If you find this to be the case, and the difference between the manual and machine leaves you confused or unsure about something, check our website for an updated version. We post current manuals and manual updates for free on our website at www.grizzly.com.

Alternatively, you can call our Technical Support for help. Before calling, make sure you write down the **manufacture date** and **serial number** from the machine ID label (see below). This information is required for us to provide proper tech support, and it helps us determine if updated documentation is available for your machine.

		MODEL GXXXX MACHINE NAME	
SPECIFICATIONS		▲ WARNING!	
Motor:		To reduce risk of serious injury when using this machine:	
Specification:		1. Read manual before operation.	
Specification:		2. Wear safety glasses and respirator.	
Specification:		3. Make sure safety is correctly adjusted/setup and	
Specification:		power is connected to grounded circuit before starting.	
Weight:		4. Make sure the motor has stopped and disconnect	
		power before adjustments, maintenance, or service.	
		5. DO NOT expose to rain or dampness.	
		6. DO NOT modify this machine in any way.	
		7.	
		8.	
		9. Do not use while tired, drowsy, or under the influence of drugs or alcohol.	
		10. Maintain machine carefully to prevent accidents.	
Manufactured for Grizzly in Taiwan			

Manufacture Date

Serial Number



Identification (G0514X)

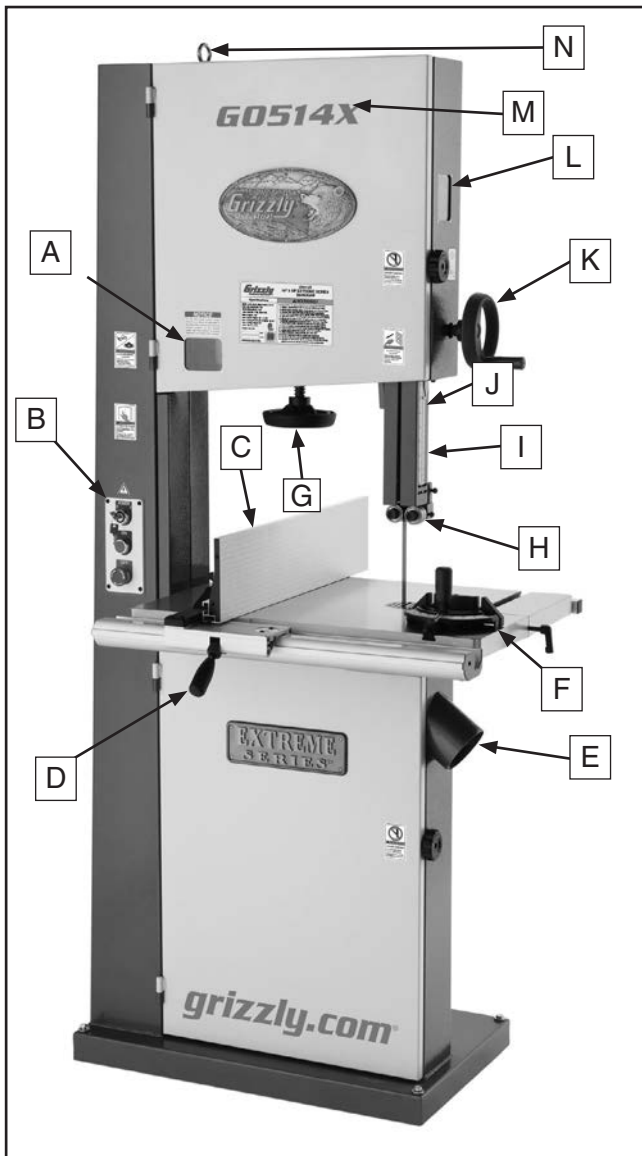

Figure 1. Bandsaw front view.

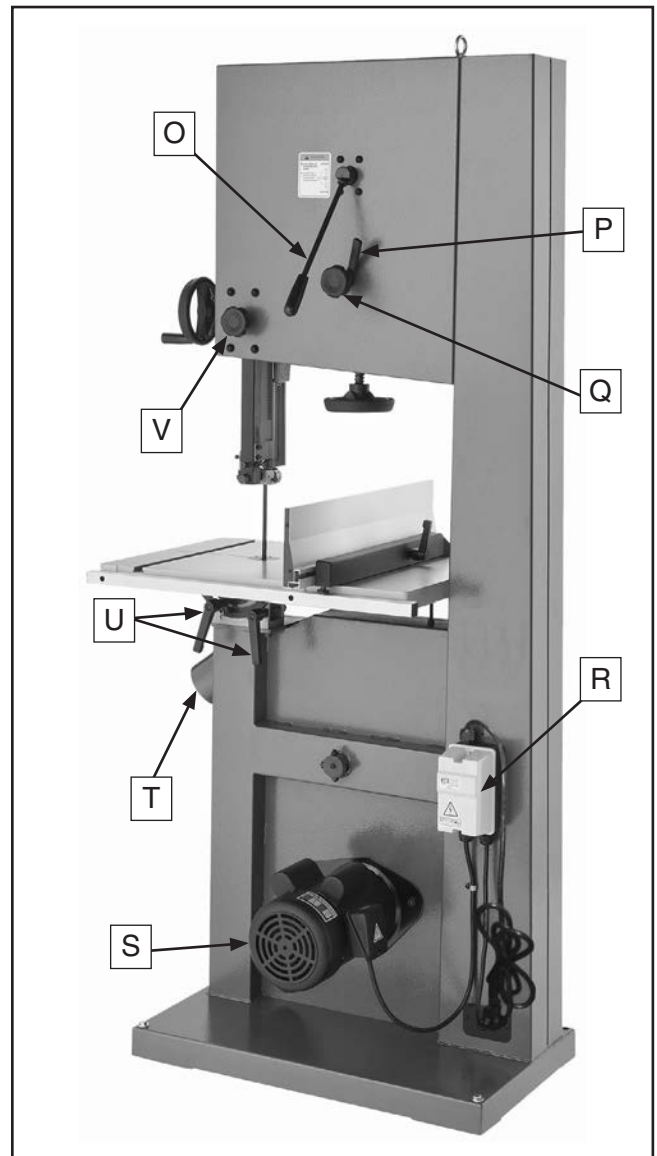

Figure 2. Bandsaw rear view.

- A. Tension Indicator Window
- B. Key Switch, Start and Stop Buttons
- C. Resaw Fence
- D. Fence Locking Lever
- E. Dust Port 4"
- F. Miter Gauge
- G. Blade Tension Handwheel
- H. Ball Bearing Blade Guides
- I. Guide Post
- J. Cutting Height Scale
- K. Guide Post Handwheel
- L. Blade Tracking Window

- S. Motor
- T. Dust Port 4"
- M. Hinged Door
- N. Lifting Eye Bolt
- O. Quick Release Blade Tension Lever
- P. Blade Tracking Lock Lever
- Q. Blade Tracking Knob
- R. Magnetic Switch
- S. Motor
- T. Dust Port 4"
- V. Guide Post Lock Knob
- U. Table Tilt Lock Handles



Identification (G0514X2/G0514X2B/G0514X3)

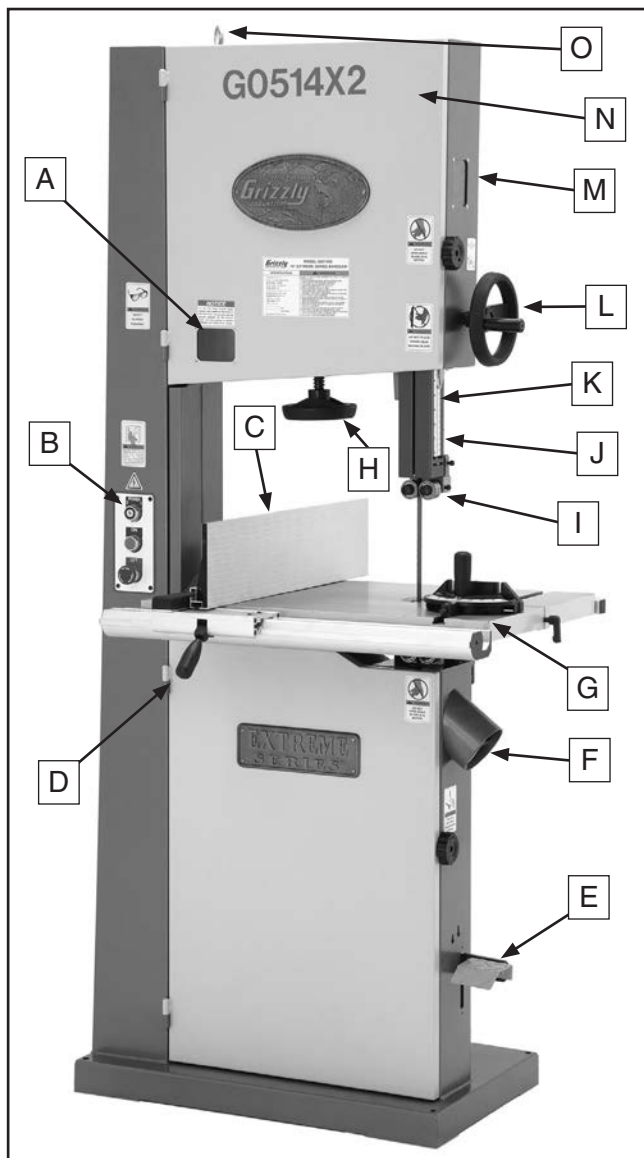

Figure 3. Bandsaw front view.

- A. Tension Indicator Window
- B. Key Switch, Start and Stop Buttons
- C. Rip Fence
- D. Fence Locking Lever
- E. Foot Brake
- F. Dust Port 4"
- G. Miter Gauge
- H. Blade Tension Handwheel
- I. Ball Bearing Blade Guides
- J. Guide Post
- K. Cutting Height Scale

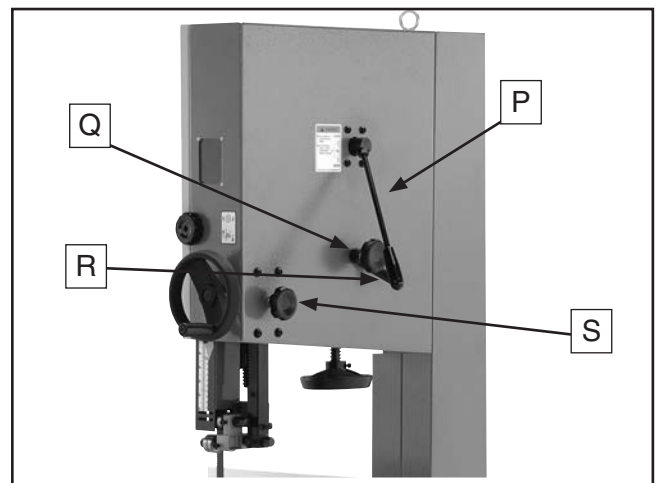

Figure 4. Rear upper controls.

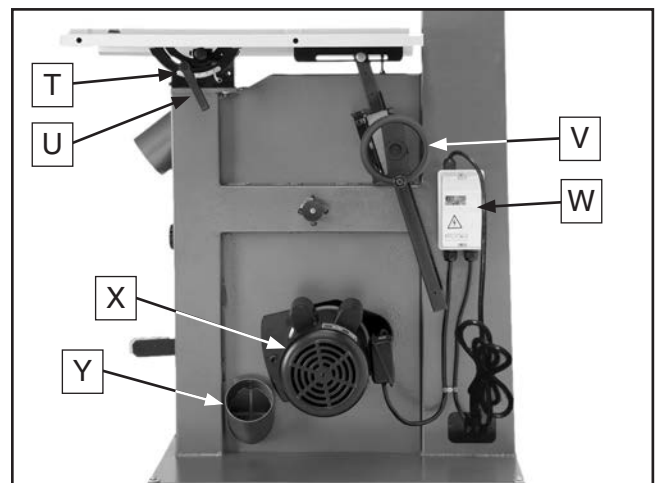

Figure 5. Table tilt controls.

- L. Guide Post Handwheel
- M. Blade Tracking Window
- N. Hinged Wheel Cover
- O. Eye Bolt
- P. Quick Release Blade Tension Lever
- Q. Blade Tracking Knob
- R. Blade Tracking Lock Lever
- S. Guide Post Lock Knob
- T. Table Tilt Scale
- U. Table Tilt Lock Lever
- V. Table Tilt Handwheel
- W. Magnetic Switch
- X. Motor
- Y. Dust Port 4"





MACHINE DATA SHEET

Customer Service #: (570) 546-9663 · To Order Call: (800) 523-4777 · Fax #: (800) 438-5901

MODEL G0514X, G0514X2, G0514X2B, G0514X3 19" 3 HP EXTREME SERIES BANDSAW

Model Number	G0514X	G0514X2	G0514X2B	G0514X3
Product Dimensions				
Weight	383 lbs.	427 lbs.		421 lbs.
Width (side-to-side) x Depth (front-to-back) x Height	36" x 32" x 76"			
Footprint (Length x Width)	29½" x 17¾"			
Shipping Dimensions				
Type	Wood Slate Crate			
Content	Machine			
Weight	460 lbs.	480 lbs.	512 lbs.	456 lbs.
Length x Width x Height	21" x 33" x 85"			
Electrical				
Power Requirement	220V, Single-Phase, 60 Hz			220V or 440V, 3-Phase, 60 Hz
Full Load Current	12A			10A at 220V 5A at 440V
Minimum Circuit Size	15A		20A	15A at 220V 10A at 440V
Prewired	220V			
Switch	Magnetic with Thermal Overload Protection			
Switch Voltage	220V			
Cord & Plug Included	NEMA 6-15		NEMA 6-20	None
Recommended Connection Type				Locking Disconnect Switch
Motor				
Type	TEFC Capacitor Start Induction			TEFC Induction
Horsepower	3 HP			
Voltage	220V			220V/440V
Phase	Single-Phase			3-Phase
Amperage	12A			10A/5A
Speed	1725 RPM			
Cycle	60 Hz			
Power Transfer	Belt Drive			
Bearings	Shielded & Permanently Lubricated			



Model Number	G0514X	G0514X2	G0514X2B	G0514X3
Operation				
Blade Speeds	1700 & 3500 FPM			
Table Tilt	Left 5°, Right 45°			
Cutting Capacities				
Maximum Cutting Height	12"			
Maximum Capacity Left of Blade	18¼"			
Blade Information				
Standard Blade Length	143"			
Blade Width Range	⅛"–1¼"			
Blade Guides	Ball Bearings			
Guide Post Size	1 ³ / ₁₆ "			
Guide Post Type	Square Tubing, 0.075" Wall Thickness			
Table Dimensions				
Length x Width x Thickness	26¾" x 19" x 1½"			
Floor to Table Height	37½"			
Fence Information				
Locks in Front	Yes			
Locks in Rear	No			
Adjustable for Blade Lead	Yes			
Construction				
Table	Precision-Ground Cast Iron			
Rip Fence	Cast Iron Fence with Extruded Aluminum Resaw Fence			
Base	Pre-Formed Steel			
Body	One-Piece Reinforced Steel			
Wheels	Computer-Balanced Cast Iron			
Wheel Tires	Polyurethane			
Wheel Covers	Pre-Formed Steel			
Trunnions	Steel	Cast Iron		
Paint	Powder Coated			
Other Related Information				
Foot Brake	No	Yes	No	Yes
Motor Brake	No		Yes	No
Wheel Diameter	18 ⁷ / ₈ "			
Dust Ports	2 x 4"			
Mobile Base Model	G7315Z			
Other Specifications				
Country of Origin	Taiwan			
Warranty	1 Year			
Serial Number Location	ID Label on Top Wheel Cover			
Assembly Time	1 Hour			



SECTION 1: SAFETY

For Your Own Safety, Read Instruction Manual Before Operating This Machine

The purpose of safety symbols is to attract your attention to possible hazardous conditions. This manual uses a series of symbols and signal words intended to convey the level of importance of the safety messages. The progression of symbols is described below. Remember that safety messages by themselves do not eliminate danger and are not a substitute for proper accident prevention measures. Always use common sense and good judgment.



Indicates an imminently hazardous situation which, if not avoided, **WILL** result in death or serious injury.



Indicates a potentially hazardous situation which, if not avoided, **COULD** result in death or serious injury.



Indicates a potentially hazardous situation which, if not avoided, **MAY** result in minor or moderate injury. It may also be used to alert against unsafe practices.

NOTICE

Alerts the user to useful information about proper operation of the machine to avoid machine damage.

Safety Instructions for Machinery

WARNING

OWNER'S MANUAL. Read and understand this owner's manual **BEFORE** using machine.

TRAINED OPERATORS ONLY. Untrained operators have a higher risk of being hurt or killed. Only allow trained/supervised people to use this machine. When machine is not being used, disconnect power, remove switch keys, or lock-out machine to prevent unauthorized use—especially around children. Make your workshop kid proof!

DANGEROUS ENVIRONMENTS. Do not use machinery in areas that are wet, cluttered, or have poor lighting. Operating machinery in these areas greatly increases the risk of accidents and injury.

MENTAL ALERTNESS REQUIRED. Full mental alertness is required for safe operation of machinery. Never operate under the influence of drugs or alcohol, when tired, or when distracted.

ELECTRICAL EQUIPMENT INJURY RISKS. You can be shocked, burned, or killed by touching live electrical components or improperly grounded machinery. To reduce this risk, only allow qualified service personnel to do electrical installation or repair work, and always disconnect power before accessing or exposing electrical equipment.

DISCONNECT POWER FIRST. Always disconnect machine from power supply **BEFORE** making adjustments, changing tooling, or servicing machine. This prevents an injury risk from unintended startup or contact with live electrical components.

EYE PROTECTION. Always wear ANSI-approved safety glasses or a face shield when operating or observing machinery to reduce the risk of eye injury or blindness from flying particles. Everyday eyeglasses are **NOT** approved safety glasses.



WARNING

WEARING PROPER APPAREL. Do not wear clothing, apparel or jewelry that can become entangled in moving parts. Always tie back or cover long hair. Wear non-slip footwear to reduce risk of slipping and losing control or accidentally contacting cutting tool or moving parts.

HAZARDOUS DUST. Dust created by machinery operations may cause cancer, birth defects, or long-term respiratory damage. Be aware of dust hazards associated with each workpiece material. Always wear a NIOSH-approved respirator to reduce your risk.

HEARING PROTECTION. Always wear hearing protection when operating or observing loud machinery. Extended exposure to this noise without hearing protection can cause permanent hearing loss.

REMOVE ADJUSTING TOOLS. Tools left on machinery can become dangerous projectiles upon startup. Never leave chuck keys, wrenches, or any other tools on machine. Always verify removal before starting!

USE CORRECT TOOL FOR THE JOB. Only use this tool for its intended purpose—do not force it or an attachment to do a job for which it was not designed. Never make unapproved modifications—modifying tool or using it differently than intended may result in malfunction or mechanical failure that can lead to personal injury or death!

AWKWARD POSITIONS. Keep proper footing and balance at all times when operating machine. Do not overreach! Avoid awkward hand positions that make workpiece control difficult or increase the risk of accidental injury.

CHILDREN & BYSTANDERS. Keep children and bystanders at a safe distance from the work area. Stop using machine if they become a distraction.

GUARDS & COVERS. Guards and covers reduce accidental contact with moving parts or flying debris. Make sure they are properly installed, undamaged, and working correctly **BEFORE** operating machine.

FORCING MACHINERY. Do not force machine. It will do the job safer and better at the rate for which it was designed.

NEVER STAND ON MACHINE. Serious injury may occur if machine is tipped or if the cutting tool is unintentionally contacted.

STABLE MACHINE. Unexpected movement during operation greatly increases risk of injury or loss of control. Before starting, verify machine is stable and mobile base (if used) is locked.

USE RECOMMENDED ACCESSORIES. Consult this owner's manual or the manufacturer for recommended accessories. Using improper accessories will increase the risk of serious injury.

UNATTENDED OPERATION. To reduce the risk of accidental injury, turn machine **OFF** and ensure all moving parts completely stop before walking away. Never leave machine running while unattended.

MAINTAIN WITH CARE. Follow all maintenance instructions and lubrication schedules to keep machine in good working condition. A machine that is improperly maintained could malfunction, leading to serious personal injury or death.

DAMAGED PARTS. Regularly inspect machine for damaged, loose, or mis-adjusted parts—or any condition that could affect safe operation. Immediately repair/replace **BEFORE** operating machine. For your own safety, **DO NOT** operate machine with damaged parts!

MAINTAIN POWER CORDS. When disconnecting cord-connected machines from power, grab and pull the plug—**NOT** the cord. Pulling the cord may damage the wires inside. Do not handle cord/plug with wet hands. Avoid cord damage by keeping it away from heated surfaces, high traffic areas, harsh chemicals, and wet/damp locations.

EXPERIENCING DIFFICULTIES. If at any time you experience difficulties performing the intended operation, stop using the machine! Contact our Technical Support at (570) 546-9663.



Additional Safety for Bandsaws

WARNING

Serious cuts, amputation, or death can occur from contact with the moving saw blade during operation or if blade breakage occurs. Serious injury or death can also occur from getting fingers, hair, or clothing entangled in moving parts if the machine is operated while the doors are open. To reduce this risk, anyone operating this machine MUST completely heed the hazards and warnings below.

HAND PLACEMENT. Placing hands or fingers in line with blade during operation may result in serious injury if hands slip or workpiece moves unexpectedly. Do not position fingers or hands in line with blade, and never reach under table while blade is moving.

SMALL/NARROW WORKPIECES. If hands slip during a cut while holding small workpieces with fingers, serious personal injury could occur. Always support/feed small or narrow workpieces with push sticks, push blocks, jig, vise, clamping fixture.

BLADE SPEED. Cutting workpiece before blade is at full speed could cause blade to grab workpiece and pull hands into blade. Allow blade to reach full speed before starting cut. **DO NOT** start machine with workpiece contacting blade.

FEED RATE. To avoid risk of workpiece slipping and causing operator injury, always feed stock evenly and smoothly.

BLADE CONDITION. Dull blades require more effort to perform cut, increasing risk of accidents. Do not operate with dirty, dull, cracked or badly worn blades. Inspect blades for cracks and missing teeth before each use. Always maintain proper blade tension and tracking while operating.

CLEARING JAMS AND CUTOFFS. Always stop bandsaw and disconnect power before clearing scrap pieces that get stuck between blade and table insert. Use brush or push stick, not hands, to clean chips/cutoff scraps from table.

BLADE CONTROL. To avoid risk of injury due to blade contact, always allow blade to stop on its own. **DO NOT** try to stop or slow blade with your hand or the workpiece.

GUARDS/COVERS. Blade guards and covers protect operator from moving bandsaw blade. The wheel covers protect operator from getting entangled with rotating wheels or other moving parts. **ONLY** operate bandsaw with blade guard in proper position and wheel covers completely closed.

BLADE REPLACEMENT. To avoid mishaps that could result in operator injury, make sure blade teeth face down toward table and blade is properly tensioned and tracked before operating.

UPPER BLADE GUIDE SUPPORT. To reduce exposure of operator to blade and provide maximum blade support while cutting, keep upper blade guides adjusted to just clear workpiece.

CUTTING TECHNIQUES. To avoid blade getting pulled off wheels or accidentally breaking and striking operator, always turn bandsaw **OFF** and wait for blade to come to a complete stop before backing workpiece out of blade. **DO NOT** back workpiece away from blade while bandsaw is running. **DO NOT** force or twist blade while cutting, especially when sawing small curves. This could result in blade damage or breakage.

WORKPIECE SUPPORT. To maintain maximum control and reduce risk of blade contact/breakage, always ensure adequate support of long/large workpieces. Always keep workpiece flat and firm against table/fence when cutting to avoid loss of control. If necessary, use a jig or other workholding device.

WORKPIECE MATERIAL. This machine is intended for cutting natural and man-made wood products, and laminate covered wood products. This machine is **NOT** designed to cut metal, glass, stone, tile, etc.



SECTION 2: POWER SUPPLY

Availability

Before installing the machine, consider the availability and proximity of the required power supply circuit. If an existing circuit does not meet the requirements for this machine, a new circuit must be installed. To minimize the risk of electrocution, fire, or equipment damage, installation work and electrical wiring must be done by an electrician or qualified service personnel in accordance with all applicable codes and standards.

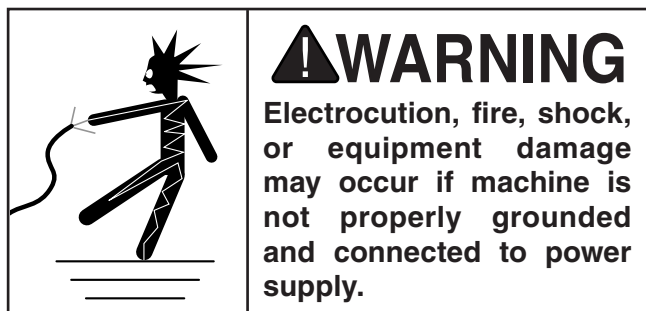

Full-Load Current Rating

The full-load current rating is the amperage a machine draws at 100% of the rated output power. On machines with multiple motors, this is the amperage drawn by the largest motor or sum of all motors and electrical devices that might operate at one time during normal operations.

G0514X, G0514X2, & G0514X2B:
Full-Load Current Rating at 220V 12 Amps

G0514X3:
Full-Load Current Rating at 220V 10 Amps
Full-Load Current Rating at 440V 5 Amps

The full-load current is not the maximum amount of amps that the machine will draw. If the machine is overloaded, it will draw additional amps beyond the full-load rating.

If the machine is overloaded for a sufficient length of time, damage, overheating, or fire may result—especially if connected to an undersized circuit. To reduce the risk of these hazards, avoid overloading the machine during operation and make sure it is connected to a power supply circuit that meets the specified circuit requirements.

! WARNING

Serious injury could occur if you connect machine to power before completing setup process. DO NOT connect to power until instructed later in this manual.

Circuit Information

A power supply circuit includes all electrical equipment between the breaker box or fuse panel in the building and the machine. The power supply circuit used for this machine must be sized to safely handle the full-load current drawn from the machine for an extended period of time. (If this machine is connected to a circuit protected by fuses, use a time delay fuse marked D.)

! CAUTION

For your own safety and protection of property, consult an electrician if you are unsure about wiring practices or electrical codes in your area.

Note: *Circuit requirements in this manual apply to a dedicated circuit—where only one machine will be running on the circuit at a time. If machine will be connected to a shared circuit where multiple machines may be running at the same time, consult an electrician or qualified service personnel to ensure circuit is properly sized for safe operation.*

G0514X, G0514X2, G0514X2B Circuit Requirements

This machine is prewired to operate on a 220V power supply circuit that has a verified ground and meets the following requirements:

Nominal Voltage Range 220V–240V
Cycle 60 Hz
Phase Single-Phase
Circuit Size (G0514X & G0514X) 15 Amps
(G0514X2B) 20 Amps



G0514X, G0514X2, G0514X2B Grounding Requirements

This machine **MUST** be grounded. In the event of certain malfunctions or breakdowns, grounding reduces the risk of electric shock by providing a path of least resistance for electric current.

For 220V operation: This machine is equipped with a power cord that has an equipment-grounding wire and a grounding plug (see following figure). The plug must only be inserted into a matching receptacle (outlet) that is properly installed and grounded in accordance with all local codes and ordinances.

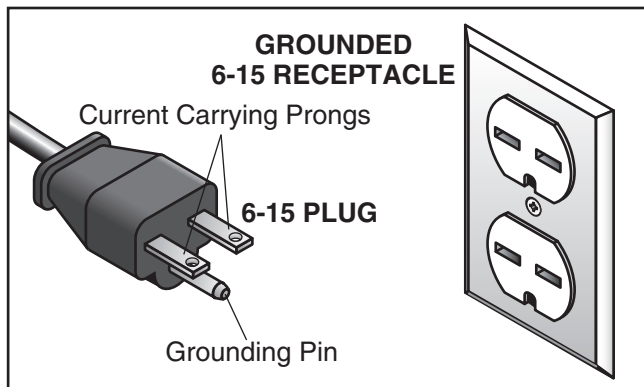

Figure 6. Typical 6-15 plug and receptacle for G0514X and G0514X2.

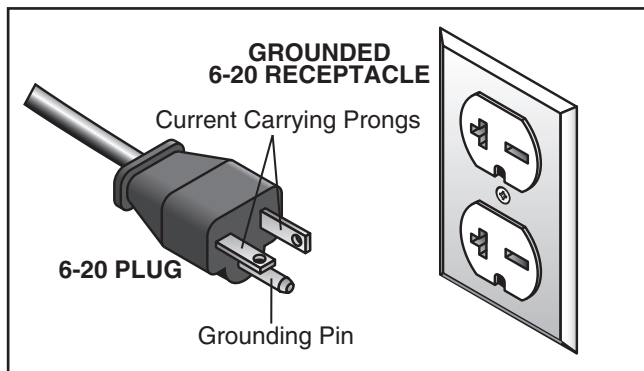
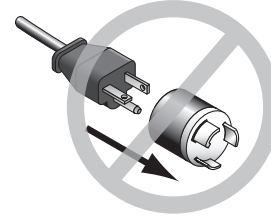

Figure 7. Typical 6-20 plug and receptacle for G0514X2B.

⚠ CAUTION



No adapter should be used with plug. If plug does not fit available receptacle, or if machine must be reconnected for use on a different type of circuit, reconnection must be performed by an electrician or qualified service personnel, and it must comply with all local codes and ordinances.

Improper connection of the equipment-grounding wire can result in a risk of electric shock. The wire with green insulation (with or without yellow stripes) is the equipment-grounding wire. If repair or replacement of the power cord or plug is necessary, do not connect the equipment-grounding wire to a live (current carrying) terminal.

Check with a qualified electrician or service personnel if you do not understand these grounding requirements, or if you are in doubt about whether the tool is properly grounded. If you ever notice that a cord or plug is damaged or worn, disconnect it from power, and immediately replace it with a new one.

G0514X, G0514X2, G0514X2B Extension Cords

We do not recommend using an extension cord with this machine. If you must use an extension cord, only use it if absolutely necessary and only on a temporary basis.

Extension cords cause voltage drop, which can damage electrical components and shorten motor life. Voltage drop increases as the extension cord size gets longer and the gauge size gets smaller (higher gauge numbers indicate smaller sizes).

Any extension cord used with this machine must be in good condition and contain a ground wire and matching plug/receptacle. Additionally, it must meet the following size requirements:

Minimum Gauge Size 14 AWG
Maximum Length (Shorter is Better).....50 ft.



G0514X3 Circuit Requirements 220V

This machine is prewired to operate on a 220V power supply circuit that has a verified ground and meets the following requirements:

Nominal Voltage Range 220V–240V
Cycle 60 Hz
Phase 3-Phase
Power Supply Circuit 15 Amps
Connection Type..Locking Disconnect Switch

G0514X3 Circuit Requirements 440V

This machine can be converted to operate on a 440V power supply (refer to **Voltage Conversion** instructions) that has a verified ground and meets the following requirements:

Nominal Voltage Range 440V–480V
Cycle 60 Hz
Phase 3-Phase
Power Supply Circuit 15 Amps
Connection Type..Locking Disconnect Switch

G0514X3 Grounding Instructions

In the event of a malfunction or breakdown, grounding provides a path of least resistance for electrical current to reduce the risk of electric shock. A permanently connected machine must be connected to a grounded metal permanent wiring system; or to a system having an equipment-grounding conductor. All grounds must be verified and rated for the electrical requirements of the machine. Improper grounding can increase the risk of electric shock!

A permanently connected (hardwired) power supply is typically installed with wires running through mounted and secured conduit. A disconnecting means, such as a locking switch (see following figure), must be provided to allow the machine to be disconnected (isolated) from the power supply when required. This installation must be performed by an electrician in accordance with all applicable electrical codes and ordinances.

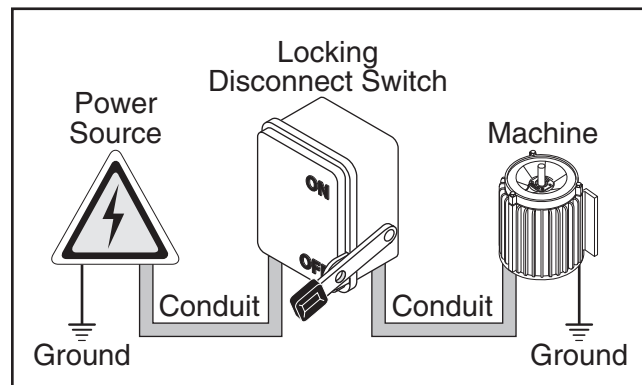

Figure 8. Typical setup of a permanently connected machine.

G0514X3 Extension Cords

Since this machine must be permanently connected to the power supply, an extension cord cannot be used.

G0514X3 Phase Converter Caution

The power from the manufactured leg may damage electrical components if connected to the wrong incoming power terminal on your machine. Only connect the manufactured leg to the L2 terminal (see **Page 72** for identification).



G0514X3 440V Conversion

The Model G0514X3 can be converted for 440V operation. This conversion job consists of disconnecting the saw from the power source, changing the connections on the magnetic switch and rewiring the motor for 440V operation.

The Model G0514X3 440V Conversion Kit (Part #P0514X3161AV2) for this procedure can be purchased by calling Grizzly Customer Service at (800) 523-4777.

All wiring changes must be performed by an electrician or qualified service personnel before the bandsaw is connected to the power source. If, at any time during this procedure you need help, call Grizzly Tech Support at (570) 546-9663.

To rewire the Model G0514X3 for 440V operation:

1. DISCONNECT BANDSAW FROM POWER!
2. Remove the magnetic switch cover, then disconnect and remove the 220V magnetic switch (**Figure 9**).

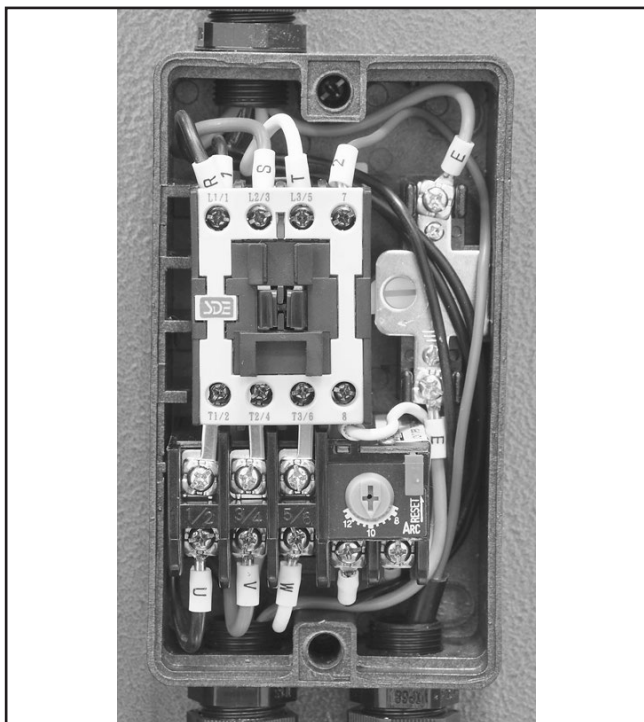

Figure 9. 220V magnetic switch

3. Install the 440V magnetic switch and wire it according to the **G0514X3 Wiring Diagram** on **Page 72**.
4. Remove the motor junction box cover, rewire the motor as shown on the diagram located inside the junction box, then re-install the cover.

Note: *The reference motor wiring diagram on Page 72 was current at the time of printing, but always use the wiring diagram provided inside the motor junction box, as it will reflect any changes to the motor shipped with your machine.*



SECTION 3: SETUP

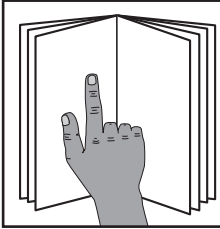

!WARNING

To reduce your risk of serious injury, read this entire manual **BEFORE** using machine.



!WARNING

Wear safety glasses during the entire setup process!

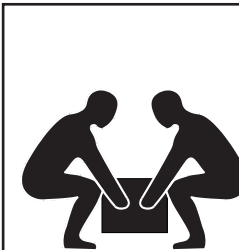

!WARNING

This machine and its components are very heavy. Get lifting help or use power lifting equipment such as a forklift to move heavy items.

Needed for Setup

The following are needed to complete the setup process, but are not included with your machine.

Description	Qty
• Safety Glasses	1
• Cleaner/Degreaser	As Needed
• Disposable Shop Rags.....	As Needed
• Forklift/Strap or Chain w/Lifting Hook (Each component rated for at least 1000 lbs)	
.....	1 Each
• 1x4 & 2x4 Shims (Optional).....	1 Each
• Additional People	1
• Straightedge	1
• Dust Collection System	1
• Dust Hose 4"	1
• Hose Clamps 4"	2



G0514X Inventory

The following is a list of items shipped with your machine. Before beginning setup, lay these items out and inventory them.

If any non-proprietary parts are missing (e.g. a nut or a washer), we will gladly replace them; or for the sake of expediency, replacements can be obtained at your local hardware store.

Crate Contents (Figure 10 & 11):	Qty
A. Bandsaw (not shown)	1
B. Table	1
C. Miter Gauge.....	1
D. Guide Post Handwheel.....	1
E. Back Square Tube.....	1
F. Resaw Fence	1
G. Front Rail	1
H. Fence Assembly.....	1

Hardware and Tools (not shown):	Qty
• Bandsaw Blade 6 TPI Hook 143"	1
• Eye Bolt M10-1.5 (may be installed)	1
• Flat Washers 8mm (Table, Fence)	5
• Lock Washers 8mm (Table)	4
• Hex Bolts M8-1.25 x 16 (Table)	4
• Hex Bolt M8-1.25 x 90 (Pos. Stop)	1
• Hex Nuts M8-1.25 (Pos. Stop, Fence)	2
• Table Pin.....	1
• Table Insert.....	1
• Cap Screws M6-1 x 16 (Fence).....	2
• Hex Bolts M6-1 x 20 (Fence).....	2
• Fence Handle M8-1.25 x 22 (Fence).....	1
• Lock Washers 6mm (Fence)	2
• Flat Washers 6mm (Fence)	2
• Rail Pad Adjustment Screw M6 x 18 (Fence)	1
• Hex Nut M6-1 (Fence)	1
• Lock Handle M8-1.25 x 44 (Fence)	1
• Moving Plate (Fence).....	1
• Hex Wrench 5mm & 8mm	1 Ea
• Open End Wrench 10 x 13mm	1

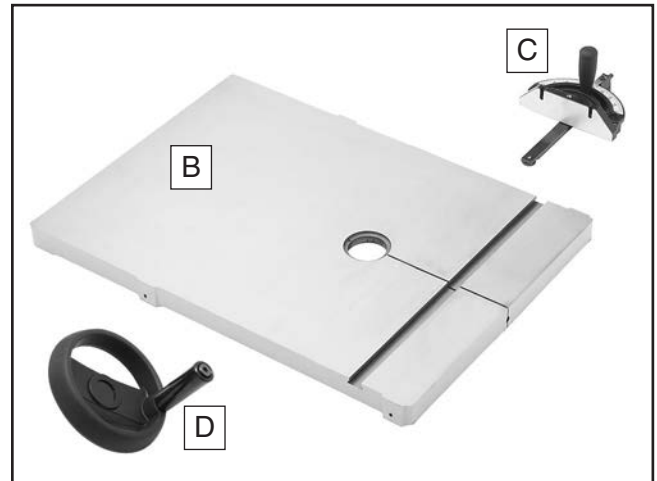

Figure 10. Bandsaw components.

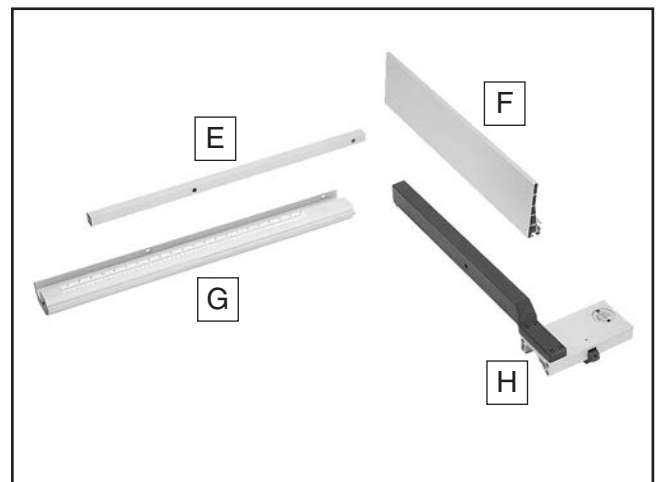

Figure 11. Fence components.

NOTICE

If you cannot find an item on this list, carefully check around/inside the machine and packaging materials. Often, these items get lost in packaging materials while unpacking or they are pre-installed at the factory.



G0514X2 & G0514X3 Inventory

The following is a list of items shipped with your machine. Before beginning setup, lay these items out and inventory them.

If any non-proprietary parts are missing (e.g. a nut or a washer), we will gladly replace them; or for the sake of expediency, replacements can be obtained at your local hardware store.

Crate Contents (Figure 12–14):	Qty
A. Bandsaw (not shown).....	1
B. Table.....	1
C. Miter Gauge.....	1
D. Back Square Tube.....	1
E. Resaw Fence.....	1
F. Front Rail.....	1
G. Fence Assembly.....	1
H. Sliding Plate.....	1
I. Table Tilt Handwheel.....	1
J. Guide Post Handwheel.....	1

Hardware and Tools (not shown):	Qty
• Bandsaw Blade 6 TPI Hook 143".....	1
• Eye Bolt M10-1.5 (may be installed).....	1
• Flat Washers 8mm (Table, Sliding Plate, Fence).....	7
• Lock Washers 8mm (Table).....	4
• Hex Bolts M8-1.25 x 25 (Table).....	4
• Cap Screw M8-1.25 x 55 (Sliding Plate).....	1
• Lock Nut M8-1.25 (Sliding Plate).....	1
• Cap Screws M6-1 x 12 (Sliding Plate).....	2
• Hex Bolt M8-1.25 x 90 (Pos. Stop).....	1
• Hex Nuts M8-1.25 (Pos. Stop, Fence).....	2
• Table Pin.....	1
• Table Insert.....	1
• Cap Screws M6-1 x 16 (Fence).....	2
• Hex Bolts M6-1 x 20 (Fence).....	2
• Fence Handle M8-1.25 x 22 (Fence).....	1
• Hex Nut M6-1 (Fence).....	1
• Lock Handle M8-1.25 x 44 (Fence).....	1
• Moving Plate (Fence).....	1
• Lock Washers 6mm (Fence, Sliding Plate).....	4
• Flat Washers 6mm (Fence, Sliding Plate).....	4
• Hex Wrench 5mm & 8mm.....	1 Ea
• Open End Wrench 10 x 13mm.....	1

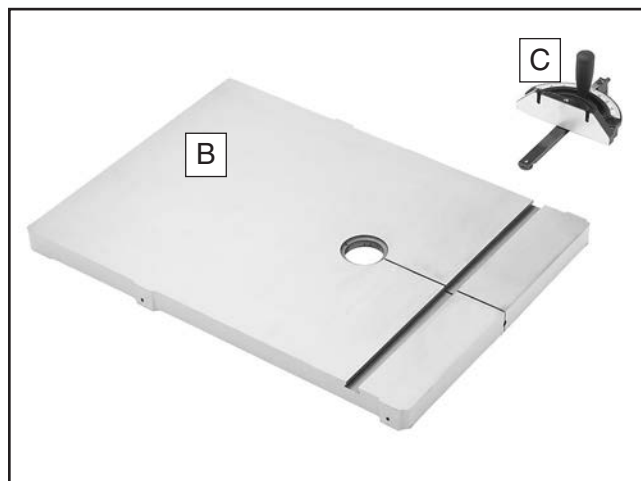

Figure 12. Bandsaw components.

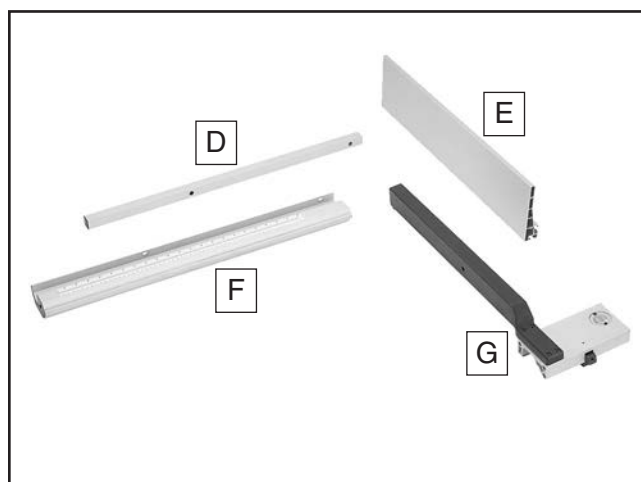

Figure 13. Fence components.



Figure 14. Table tilt components.

NOTICE

If you cannot find an item on this list, carefully check around/inside the machine and packaging materials. Often, these items get lost in packaging materials while unpacking or they are pre-installed at the factory.



G0514X2B

The following is a list of items shipped with your machine. Before beginning setup, lay these items out and inventory them.

If any non-proprietary parts are missing (e.g. a nut or a washer), we will gladly replace them; or for the sake of expediency, replacements can be obtained at your local hardware store.

Crate Contents (Figure 15–17):	Qty
A. Bandsaw (not shown)	1
B. Table	1
C. Miter Gauge	1
D. Standard Fence Assembly	1
E. Resaw Fence	1
F. Resaw Fence Lock Lever M8-1.25 x 45	1
G. Resaw Fence T-Bar	1
H. Front Square Rail	1
I. Sliding Plate	1
J. Table Tilt Handwheel	1
K. Guide Post Handwheel	1

Hardware and Tools (not shown):	Qty
• Bandsaw Blade 6 TPI Hook 143"	1
• Eye Bolt M10-1.5 (may be installed)	1
• Flat Washers 8mm (Table, Sliding Plate, Fence)	10
• Lock Washers 8mm (Table)	5
• Hex Bolts M8-1.25 x 25 (Table)	5
• Hex Bolt M8-1.25 x 55 (Sliding Plate)	1
• Lock Nut M8-1.25 (Sliding Plate)	1
• Cap Screws M6-1 x 12 (Sliding Plate)	2
• Hex Bolt M8-1.25 x 90 (Pos. Stop)	1
• Hex Nuts M8-1.25 (Pos. Stop, Fence)	1
• Table Pin	1
• Table Insert	1
• Cap Screws M6-1 x 20 (Fence)	3
• Lock Handle M8-1.25 x 44 (Fence)	1
• Moving Plate (Fence)	1
• Cap Screw M8-1.25 x 20 (Fence)	1
• Lock Washers 6mm (Fence, Sliding Plate)	5
• Flat Washers 6mm (Fence, Sliding Plate)	5
• Outer Rail Plates (Fence)	3
• Hex Wrench 5mm & 8mm	1 Ea
• Knob M8-1.25 x 20	2
• Open End Wrench 10 x 13mm	1

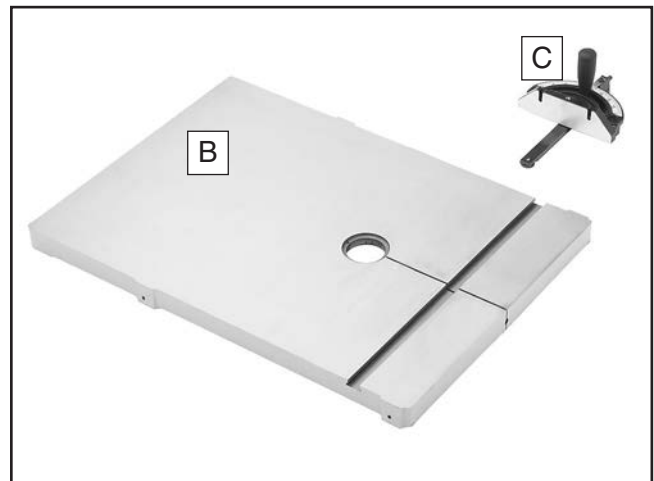

Figure 15. Bandsaw components.

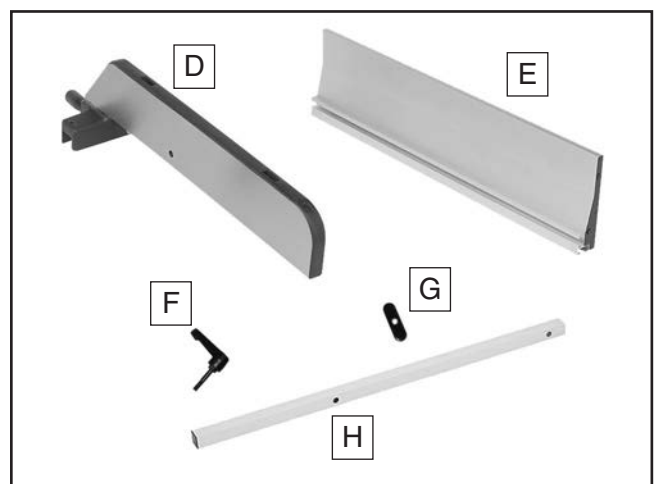

Figure 16. Fence components.



Figure 17. Foot brake and table tilt components.



Hardware Recognition Chart

USE THIS CHART TO MATCH UP HARDWARE DURING THE ASSEMBLY PROCESS.

MEASURE BOLT DIAMETER BY PLACING INSIDE CIRCLE

- #10
- 1/4"
- 5/16"
- 3/8"
- 7/16"
- 1/2"

- 4mm
- 5mm
- 6mm
- 8mm
- 10mm
- 12mm
- 16mm

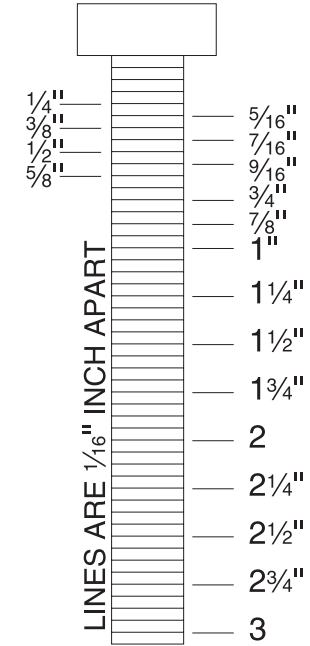
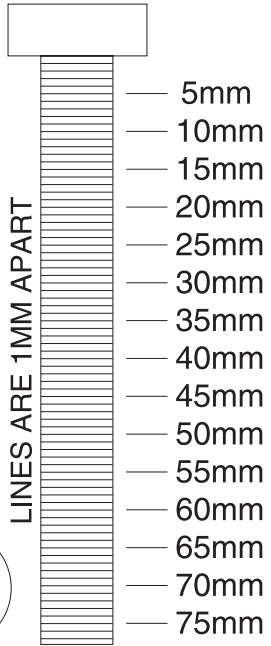
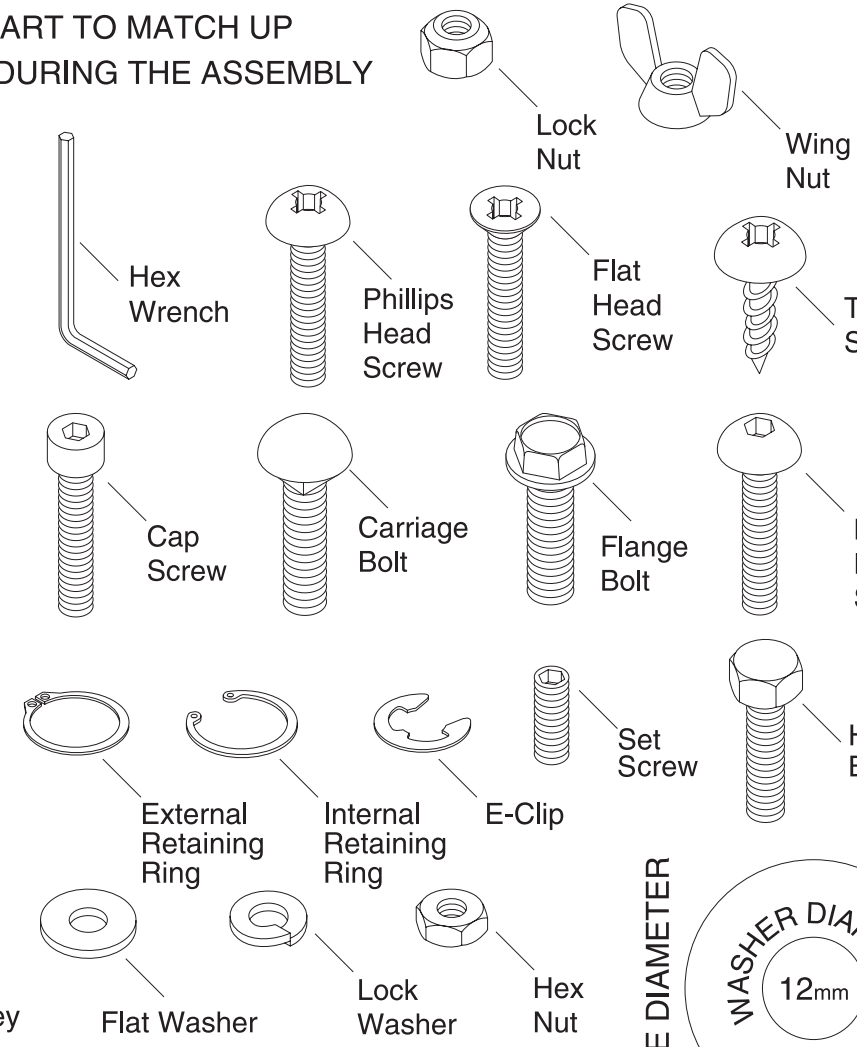

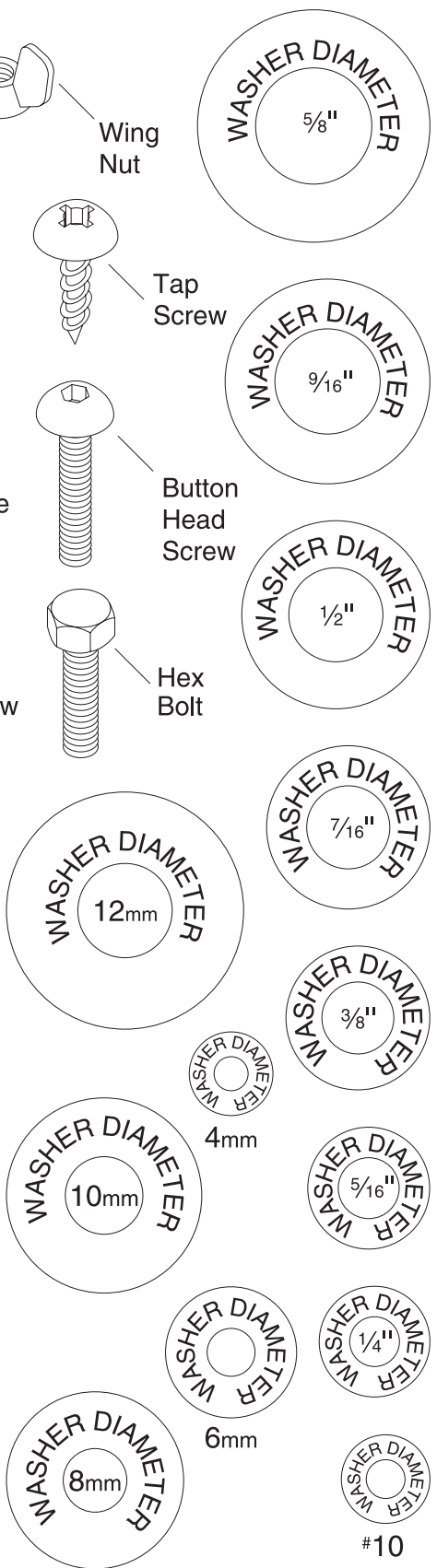

WASHERS ARE MEASURED BY THE INSIDE DIAMETER



Clean Up

The unpainted surfaces are coated with a waxy oil to prevent corrosion during shipment. Remove this protective coating with a solvent cleaner or degreaser. For thorough cleaning, some parts must be removed. **For optimum performance, clean all moving parts or sliding contact surfaces.** Avoid chlorine-based solvents, such as acetone or brake parts cleaner that may damage painted surfaces. Always follow the manufacturer's instructions when using any type of cleaning product.

	<p>⚠ WARNING Gasoline and petroleum products have low flash points and can explode or cause fire if used to clean machinery. DO NOT use these products to clean the machinery.</p>
---	--

	<p>⚠ CAUTION Many cleaning solvents are toxic if inhaled. Minimize your risk by only using these products in a well ventilated area.</p>
---	---

Site Considerations

Floor Load

Refer to the **Machine Data Sheet** for the weight and footprint specifications of your machine. Some residential floors may require additional reinforcement to support both the machine and operator.

Placement Location

Consider existing and anticipated needs, size of material to be processed through each machine, and space for auxiliary stands, work tables or other machinery when establishing a location for your new machine. See **Figure 18** for the minimum working clearances.

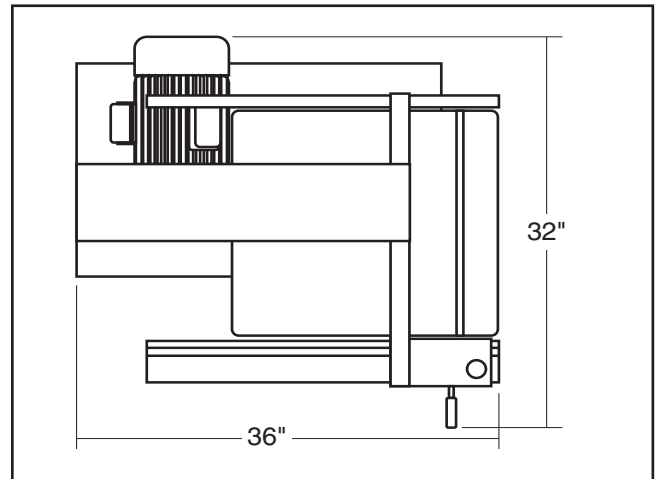
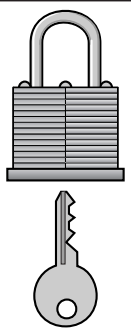
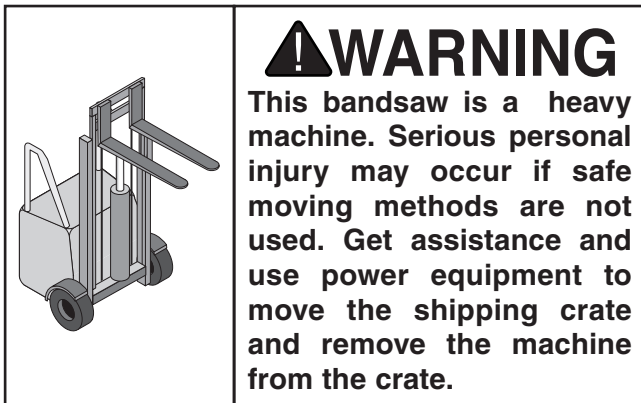

Figure 18. Minimum working clearances.

	<p>⚠ CAUTION Children and visitors may be seriously injured if unsupervised around this machine. Lock entrances to the shop or disable start switch or power connection to prevent unsupervised use.</p>
--	---



Moving & Placing Base Unit



Special care should be taken when moving this bandsaw. Only use one of the following methods to lift or move this bandsaw.

To move and place the bandsaw using the eye bolt:

1. Remove the crate from the shipping pallet, then unbolt the bandsaw from the pallet.
2. Install the eye bolt shown (see **Figure 19**), make sure it is threaded all the way in, then place the lifting hook through the eye bolt and lift the bandsaw slowly with a forklift.

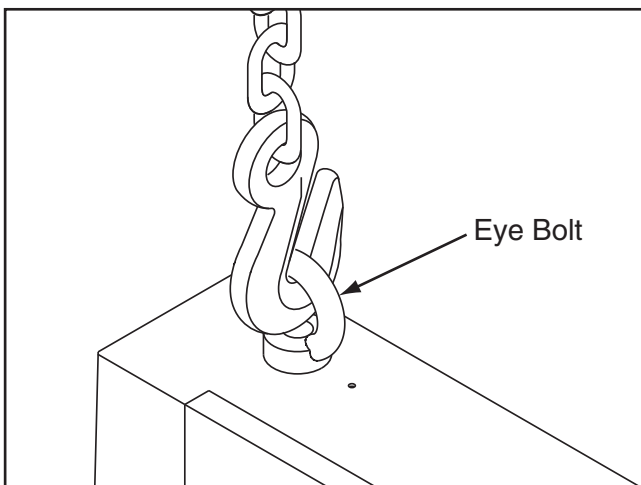

Figure 19. Lifting the bandsaw.

3. Remove the pallet and slowly set the bandsaw into position.

To move and place the bandsaw using wood shims:

1. Move the crate to the prepared location, then remove the crate from the shipping pallet.
2. Unbolt the bandsaw from the pallet.
3. Carefully place the forklift forks under the head and install a 1x4 shim between the head and the left fork and a 2x4 shim between the head and right fork so the bandsaw is level, as shown in **Figure 20**.

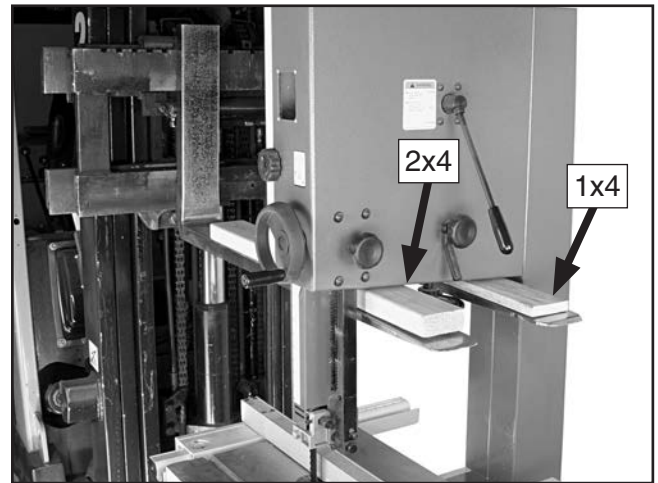

Figure 20. Example of lifting bandsaw with forklift using wood shims.

4. Lift the bandsaw off of the pallet, remove the pallet, then slowly set the bandsaw into position.

Note: If you are concerned about your forklift forks hitting the tension handwheel, remove the handwheel before positioning the forks, then reinstall it after placing.



Mounting

We recommend mounting your new machine to the floor. Because floor materials may vary, floor mounting hardware is not included. You may also mount your machine to a mobile base that has wheel locking or wheel retracting capabilities that keeps the mobile base from rolling when not in use.

Bolting to Concrete Floors

Lag shield anchors with lag bolts (**Figure 21**) and anchor studs (**Figure 22**) are two popular methods for anchoring an object to a concrete floor. We suggest you research the many options and methods for mounting your machine and choose the best that fits your specific application.

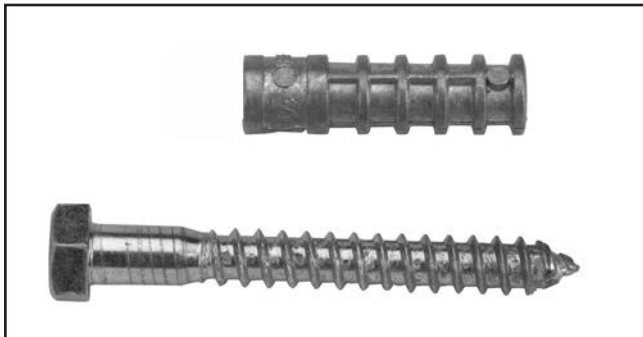

Figure 21. Typical lag shield anchor and bolt.

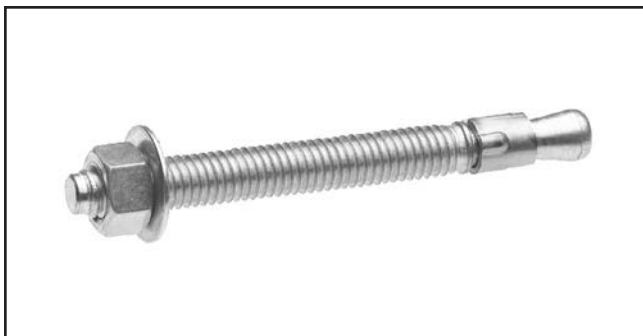

Figure 22. Typical anchor stud.

NOTICE

Anchor studs are stronger and more permanent alternatives to lag shield anchors; however, they will stick out of the floor, which may cause a tripping hazard if you decide to move your machine.

Assembly

Guide Post Handwheel

Secure the guide post handwheel onto the handwheel shaft flat with the included set screw (see **Figure 23**).

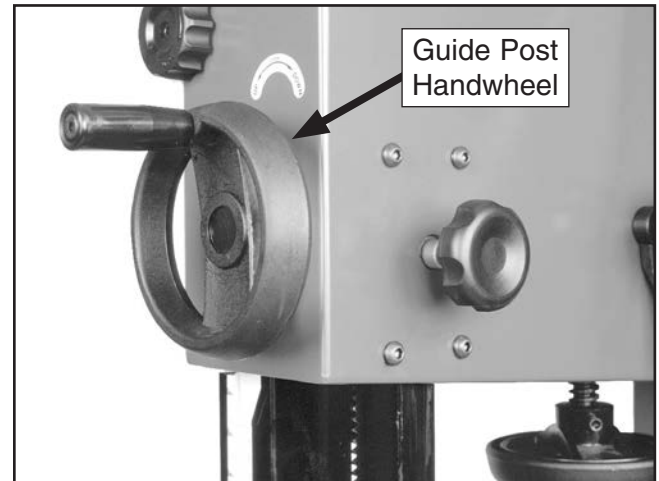

Figure 23. Guide post handwheel installed.

Table

The table is heavy and requires two people to lift it onto the trunnions. Remove the saw blade to make table installation easier.

To install the table:

1. Loosen blade tension by rotating the quick release tension lever clockwise, as shown in **Figure 24**.

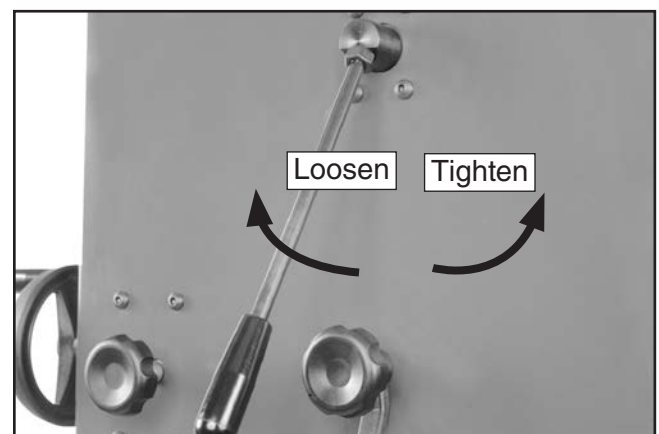
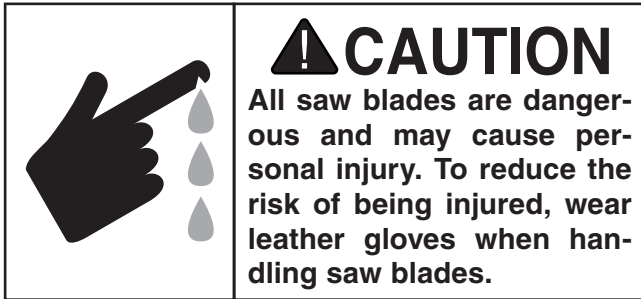

Figure 24. Quick release tension lever.



- Adjust the upper and lower blade guides away from the blade. Refer to **Adjusting Blade Guide Bearings** on **Page 33** for more details.



- With the help of another person, lift the table onto the trunnions.
- Model G0514X:** Secure the table to the trunnions, as shown in **Figure 25** with the (4) M8-1.25 x 16 hex bolts, 8mm lock washers, and 8mm flat washers.

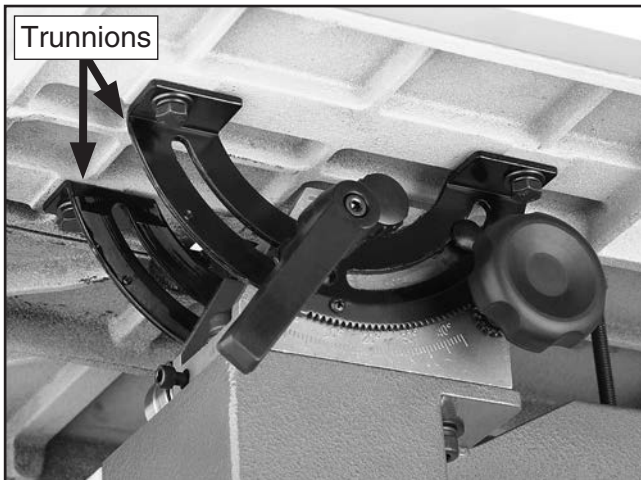

Figure 25. Mounting the table.

Model G0514X2, G0514X2B, G0514X3: Secure the table to the trunnions with the (4) M8-1.25 x 25 hex bolts, 8mm lock washers, and 8mm flat washers.

- With the blade teeth pointing downward, and toward the front of the machine, slide the blade through the table slot.

—If the table insert is preinstalled, remove it before changing the blade.

- Slide the blade through the upper and lower blade guides, and mount it over the upper and lower wheels.
- Tighten the quick release tension lever, then install the table insert and table pin.
- Keep the upper and lower blade guides adjusted away from the blade until the blade tracking and tension have been adjusted.

Table Tilt Assembly (G0514X2, G0514X2B, & G0514X3 Only)

- Tilt the table up and secure the table lock lever.
- Remove the hex bolt, hex nut and flat washers installed on the geared table tilt tube (see **Figure 26**).

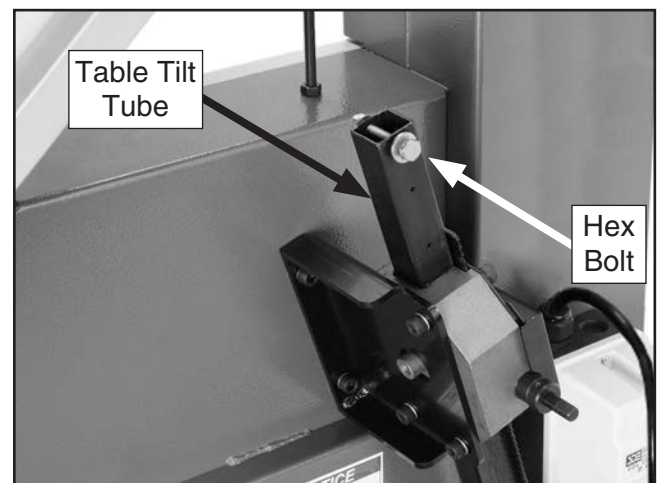

Figure 26. Table tilt assembly.

- Secure the sliding plate to the table tilt tube with the fasteners removed in **Step 2**, making sure the hole closest to the edge of the plate is installed on the left side of the table—facing the rear of the bandsaw.
- Lower the table onto the positive stop bolt.



- Secure the table tilt handwheel onto the flat part of the handwheel shaft with the included cap screw (see **Figure 27**).

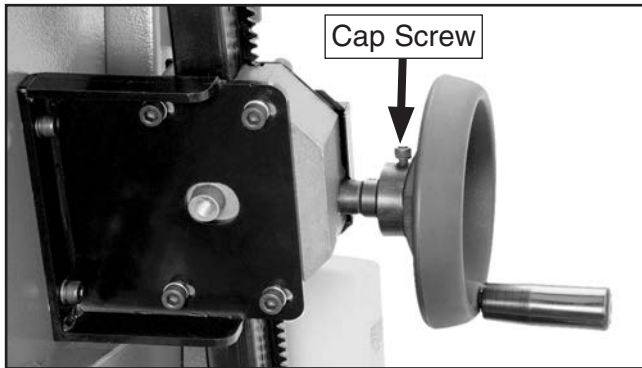

Figure 27. Table tilt handwheel installed.

- Raise the sliding plate up and secure it to the bottom of the table with the hex bolts and flat washers, as shown in **Figure 28**.

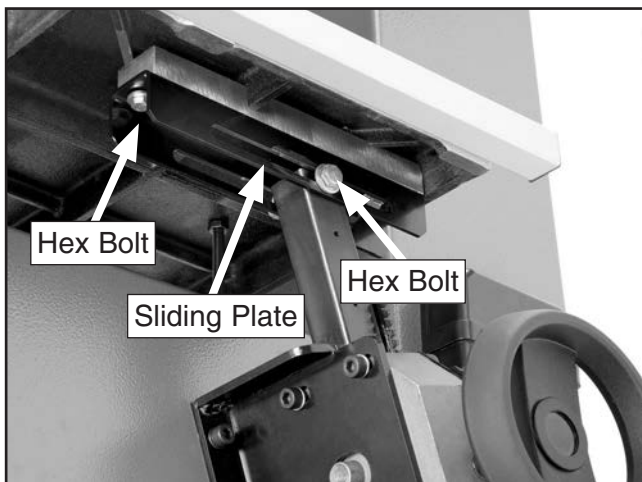
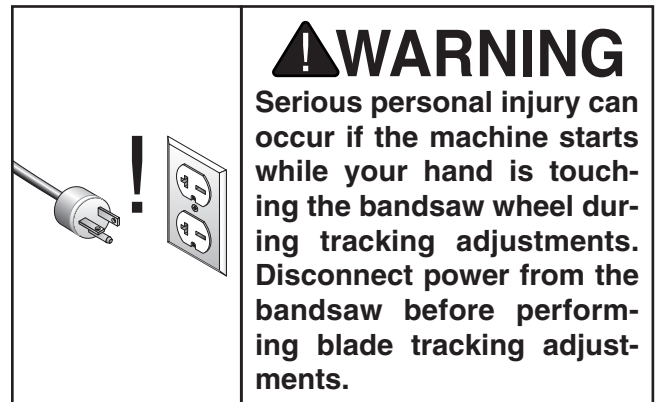

Figure 28. Sliding plate secured to table.

Blade Tracking



The blade tracking is primarily affected by the tilt of the upper wheel, also known as "Center Tracking"; and the alignment of both wheels, also known as "Coplanar Tracking." (For Coplanar Tracking, see the **Wheel Alignment** instructions on **Page 65**.)

The wheels on this bandsaw were aligned at the factory, so Center Tracking is the only adjustment that needs to be performed when the saw is new.

To center track the blade:

- DISCONNECT BANDSAW FROM POWER!
- Make sure the upper and lower blade guides are adjusted away from the blade.
- Engage the quick tension lever and turn the blade tension handwheel until the tension scale (**Figure 29**) reads between 4 and 6.

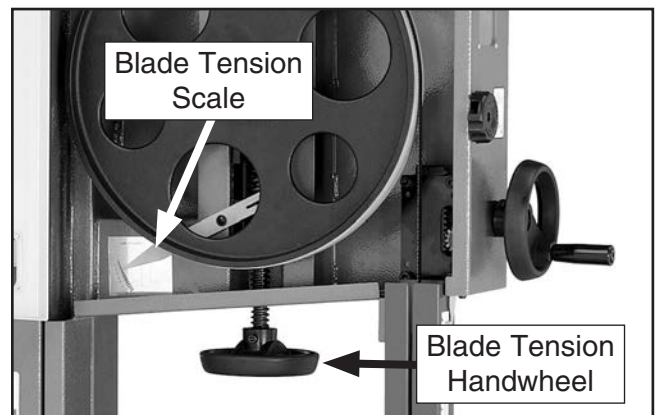

Figure 29. Blade tensioning controls.



4. Spin the upper wheel by hand at least three times and watch how the blade rides on the crown of the wheel. Refer to **Figure 30** for an illustration of this concept.

—If the blade rides in the center of the upper wheel and is centered on the peak of the wheel crown, then the bandsaw is already tracked properly and no further adjustments are needed at this time.

—If the blade does not ride in the center of the upper wheel and is not centered on the peak of the wheel crown, then continue with the following steps.

CAUTION

The cast iron spokes may have sharp edges and the blade teeth may extend beyond the edge of the wheel, creating a laceration hazard. Be careful when turning the wheels by hand.

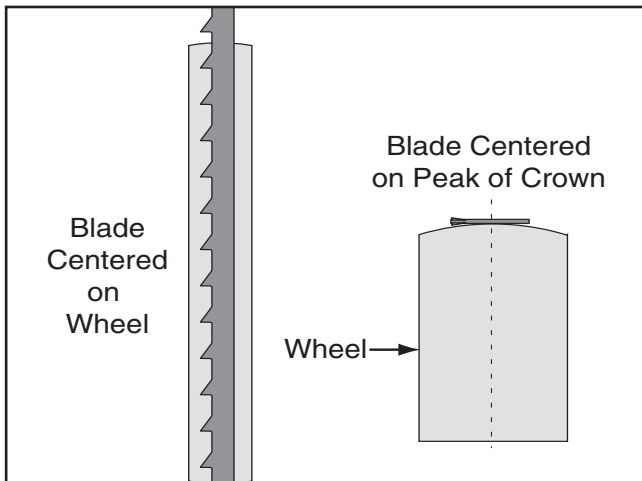

Figure 30. Center tracking profiles.

5. Loosen the lock lever (**Figure 31**) so that the blade tracking knob can rotate.

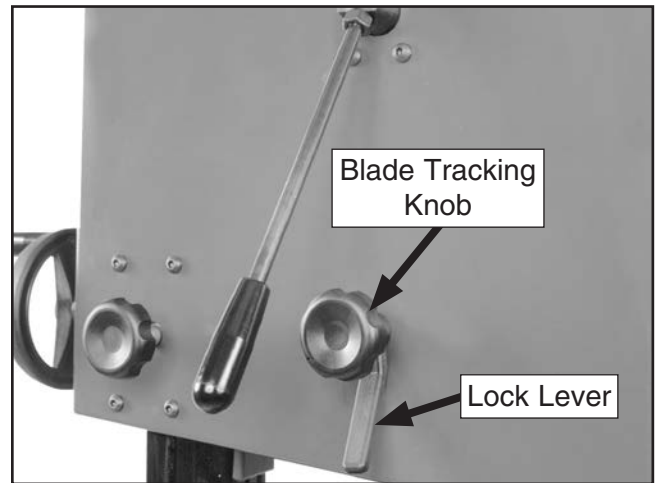

Figure 31. Blade tracking controls.

6. Spin the upper wheel with one hand and rotate the tracking control knob with the other hand to make sure the blade rides in the center of the bandsaw wheel tire.
7. Tighten the tracking control lock knob and close the upper wheel cover.

For the best performance from your saw, regularly maintain proper tracking of the blade.

NOTICE

Changes in the blade tension may change the blade tracking.



Positive Stop

The positive stop allows the table to be quickly and accurately returned to the horizontal (0°) position after being adjusted to a different angle.

Installing Positive Stop

1. DISCONNECT BANDSAW FROM POWER!
2. Unlock the table tilt lock lever, tilt the table to access the positive stop bolt installation location, then lock the lever.
3. Thread the M8-1.25 hex nut halfway onto the M8-1.25 x 90 hex bolt (this is the positive stop bolt).
4. Thread the positive stop bolt into the threaded hole on bandsaw body, as shown in **Figure 32**.

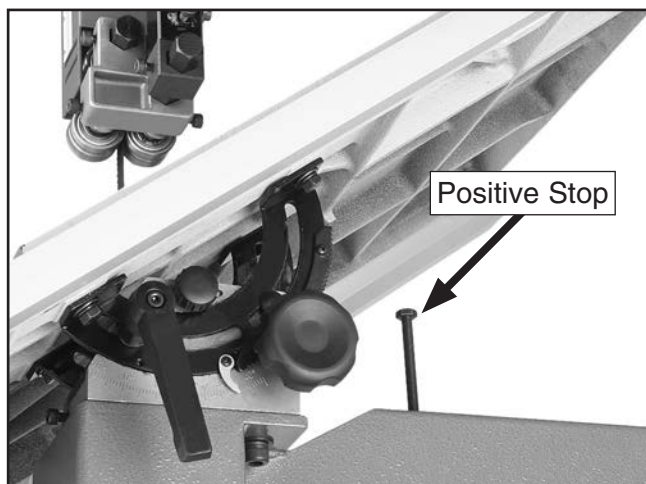

Figure 32. Installed positive stop bolt.

5. Lower the table onto the positive stop bolt.

Positioning Positive Stop

1. DISCONNECT BANDSAW FROM POWER!
2. Adjust the blade tension until the mark on the blade tension scale is between 4 and 6.
3. Loosen the hex nut that locks the positive stop bolt in place.
4. Raise the guide post and place a machinist's square on the table next to the side of the blade, as illustrated in **Figure 33**. Adjust the table square with the blade, then secure it with the table tilt lock lever (see **Figure 71** on **Page 42**).

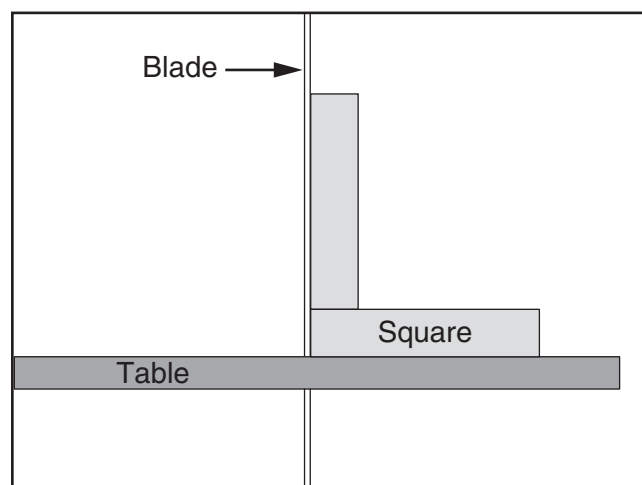

Figure 33. Squaring table to blade.

5. Adjust the positive stop bolt against the table and secure it by tightening the hex nut against the trunnion bracket.
6. Check the adjustment for accuracy once you have tightened the hex nut.
7. Loosen the screw on the pointer, but do not remove it.
8. Align the tip of the pointer with the 0° mark on the table tilt scale.
9. Tighten the screw on the pointer so that the pointer is locked in place.



Dust Collection

⚠ CAUTION

DO NOT operate this bandsaw without an adequate dust collection system. This saw creates substantial amounts of wood dust while operating. Failure to use a dust collection system can result in short and long-term respiratory illness.

Recommended CFM at Dust Port: 400 CFM

Do not confuse this CFM recommendation with the rating of the dust collector. To determine the CFM at the dust port, you must consider these variables: (1) CFM rating of the dust collector, (2) hose type and length between the dust collector and the machine, (3) number of branches or wyes, and (4) amount of other open lines throughout the system. Explaining how to calculate these variables is beyond the scope of this manual. Consult an expert or purchase a good dust collection "how-to" book.

To connect a dust collection hose:

1. Fit the 4" dust hose over each dust port and secure them in place with a hose clamp (see **Figure 34**).
2. Tug the hoses to make sure they do not come off. **Note:** A tight fit is necessary for proper performance.



Figure 34. Dust hose attached to bottom dust port.

Installing Fence (G0514X, -X2, X3)

To install the fence:

1. Attach the back square tube to the table with the (2) M6-1 x 16 cap screws as shown in **Figure 35**.
2. Attach the front rail with the (2) M6-1 x 20 hex bolts, 6mm lock washers, and 6mm flat washers, as shown in **Figure 35**.

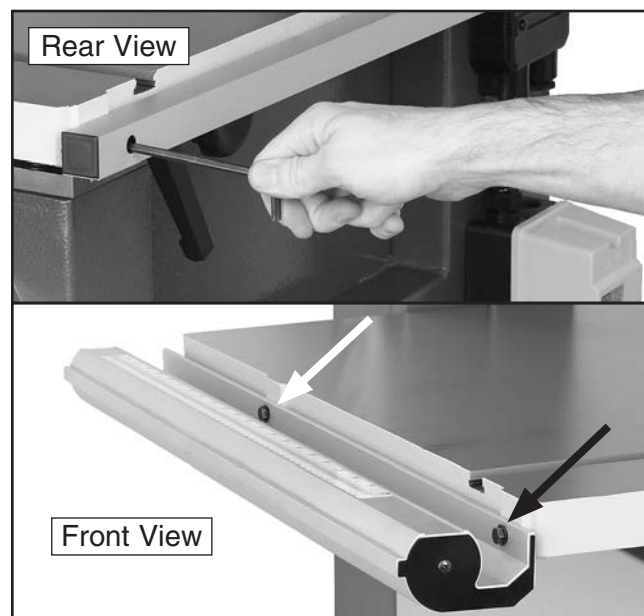

Figure 35. Rail installation.

3. Install an M8-1.25 hex nut on the fence handle, then thread the handle into the fence assembly, as shown in **Figure 36**. Tighten the hex nut against the fence pivot block to secure the handle.

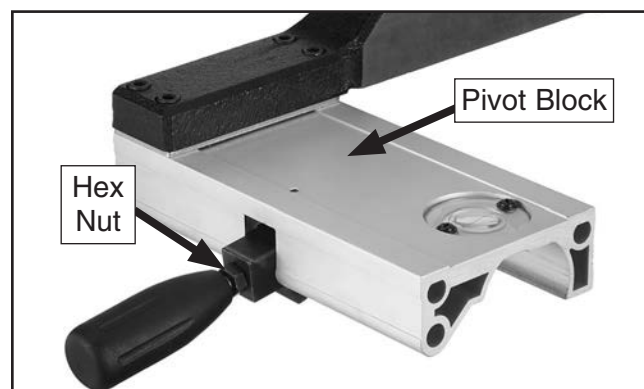

Figure 36. Handle installed on fence assembly.



4. Thread the M6-1 hex nut onto the rail pad adjustment screw, then thread the rail pad adjustment screw into the fence (see **Figure 37**).

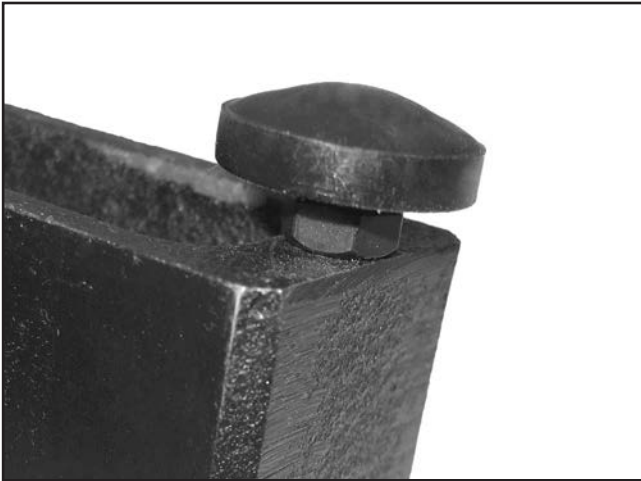

Figure 37. Installed rail pad adjustment screw.

5. Place the 8mm flat washer on the lock handle, slide it through the hole in the fence, then thread the moving plate onto the end of the lock handle threads.
6. Slide the resaw fence over the moving plate, as shown in **Figure 38**, so the moving plate fits inside the channel of the resaw fence.

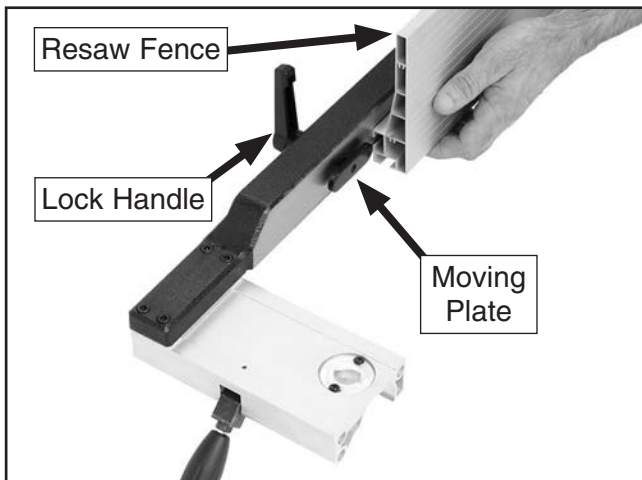

Figure 38. Attaching resaw fence to standard fence.

7. Tighten the lock handle.
8. Pull the fence handle up and place the fence assembly on the fixed rail as, shown in **Figure 39**.

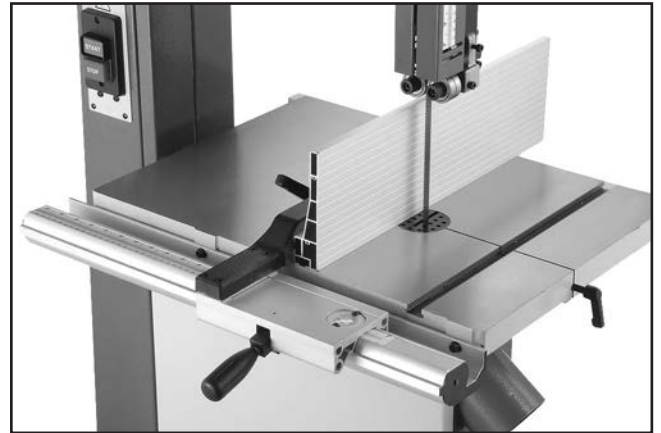

Figure 39. Correctly installed fence.

9. Push the fence handle down to lock the fence assembly in place.
10. Adjust the rail pad adjustment screw until there is an even gap between the bottom of the fence and the table, then tighten the hex nut against the fence.



Installing Fence (G0514X2B)

To install the fence:

1. Attach the rail plates to the front square rail with the three M6-1 x 20 cap screws, 6mm lock washers, and 6mm flat washers (see **Figure 40**).

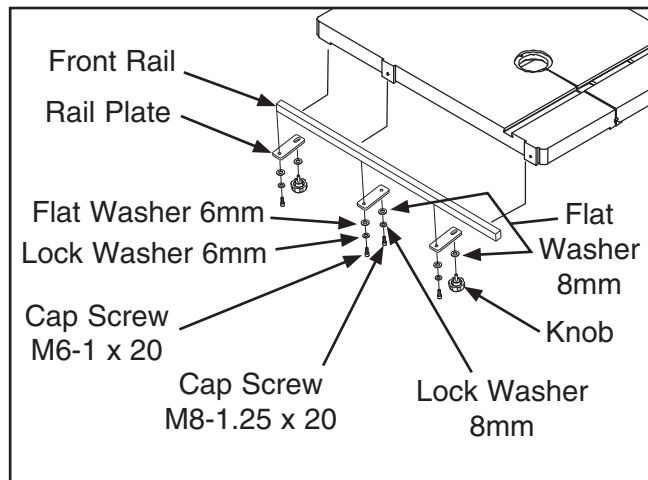

Figure 40. Installing front rail onto table.

2. Attach the outer two rail plates with the round and elongated mounting holes on the outer part of the table bottom with two M8-1.25 x 20 knobs and 8mm flat washers.
3. Attach the remaining rail plate with the round mounting holes using an M8-1.25 x 20 cap screw, 8mm lock washer and 8mm flat washer (**Figure 40**).
4. Thread the fence handle into the fence, then tighten the hex nut against the fence pivot block (see **Figure 41**).

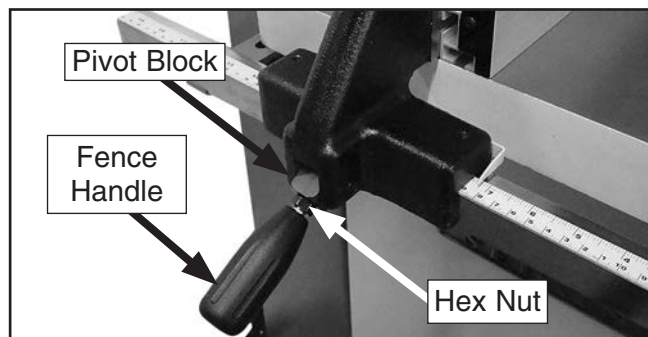

Figure 41. Fence handle components.

5. Install the resaw fence lock handle (with the washer and moving plate) onto the fence, then slide the resaw fence over the moving plate as shown in **Figure 42**.

Note: Leave the moving plate and lock handle loose enough to slide on the fence.

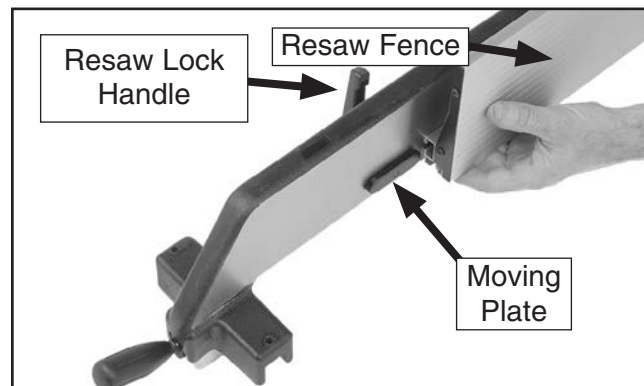

Figure 42. Attaching resaw fence to standard fence.

6. Tighten the resaw lock handle.
7. Pull the fence handle up and place the fence assembly on the rail.
8. Push the fence handle down to lock the fence assembly in place.

Installing Foot Brake (G0514X2, -X3)

Secure the foot pedal to the brake lever using the cap screws and lock washers, as shown in **Figure 43**.

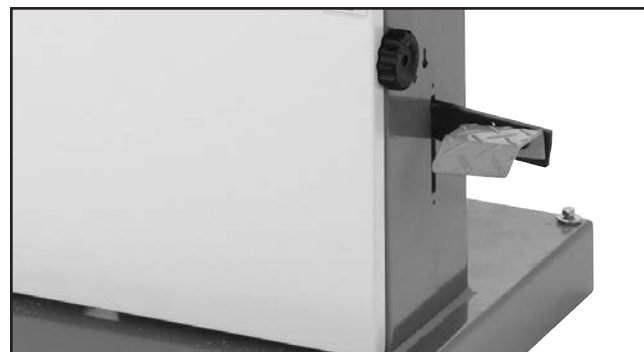

Figure 43. Foot brake installed.



G0514X, -X2, & X2B Power Connection

After you have completed all previous setup instructions and circuit requirements, the machine is ready to be connected to the power supply.

To avoid unexpected startups or property damage, use the following steps whenever connecting or disconnecting the machine from the power

Connecting Power

1. Turn the machine power switch **OFF**.
2. Insert the power cord plug into a matching power supply receptacle. The machine is now connected to the power source.

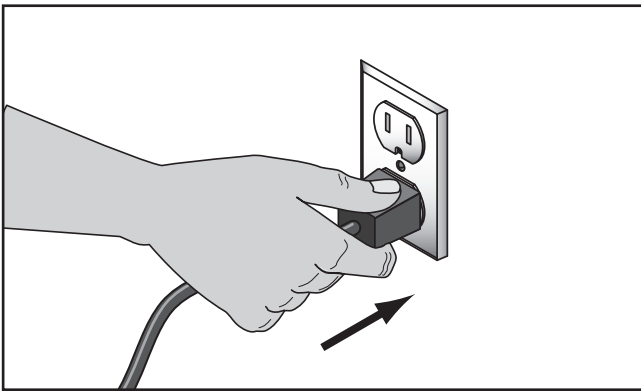

Figure 44. Connecting power.

Disconnecting Power

1. Turn the machine power switch **OFF**.
2. Grasp the molded plug and pull it completely out of the receptacle. **DO NOT** pull by the cord as this may damage the wires inside.

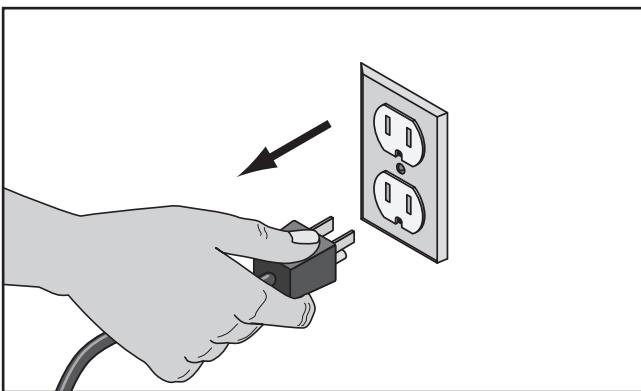

Figure 45. Disconnecting power.

G0514X/-X2/-X2B/-X3 (Mfd. Since 2/12)

G0514X3 Power Connection

Before the machine can be connected to the power source, an electrical circuit and connection device must be prepared per the **POWER SUPPLY** section in this manual; and all previous setup instructions in this manual must be complete to ensure that the machine has been assembled and installed properly. The disconnect switch installed by the electrician (as recommended) is the primary means for disconnecting or connecting the machine to the power source.

Connecting to Power Source

Move the disconnect switch handle to the **ON** position, as illustrated below. The machine is now connected to the power source.

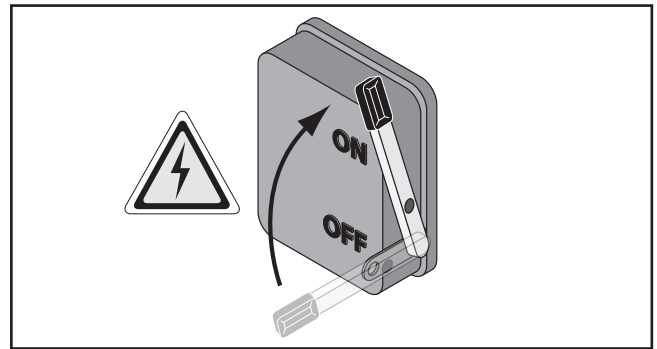

Figure 46. Connecting power to machine.

Disconnecting from Power Source

Move the disconnect switch handle to the **OFF** position, as illustrated below. The machine is now disconnected from the power source.

Note: Lock the switch in the **OFF** position to restrict others from starting the machine.

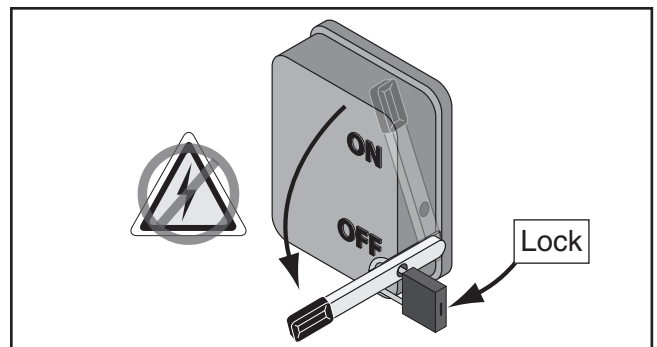

Figure 47. Disconnecting power from machine.



Test Run

Once the assembly is complete, test run your machine to make sure it runs properly and is ready for regular operation.

The test run consists of verifying the following: 1) The motor powers up and runs correctly, 2) the safety disabling mechanism on the switch works correctly, and 3) the stop button safety feature works correctly.

If, during the test run, you cannot easily locate the source of an unusual noise or vibration, stop using the machine immediately, then review **Troubleshooting** on **Page 55**.

If you still cannot remedy a problem, contact our Tech Support at (570) 546-9663 for assistance.

To test run the machine:

1. Make sure you have read the safety instructions at the beginning of the manual and that the machine is set up properly.
2. Make sure all tools and objects used during setup are cleared away from the machine.
3. Turn the machine **ON** to verify that it is operating correctly by turning the switch disabling key (**Figure 48**) to "1" .

—When operating correctly, the machine runs smoothly with little or no vibration or rubbing noises.

—Investigate and correct strange or unusual noises or vibrations before operating the machine further. Always disconnect the machine from power when investigating or correcting potential problems.

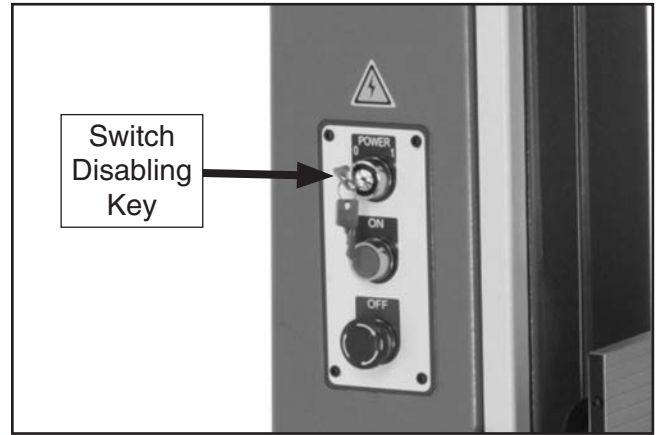

Figure 48. Switch disabling key and ON/OFF switch.

4. Press the OFF button to stop the machine.
5. WITHOUT resetting the OFF button, press the ON button. The machine should not start.
 - If the machine does not start, the OFF button safety feature is working correctly.
 - If the machine does start (with the stop button pushed in), immediately disconnect power to the machine. The OFF button safety feature is not working correctly. This safety feature must work properly before proceeding with regular operations. Call Tech Support for help.
6. Push the OFF button in, then twist it clockwise so it pops out. When the OFF button pops out, the switch is reset and ready for operation (see **Figure 49**).

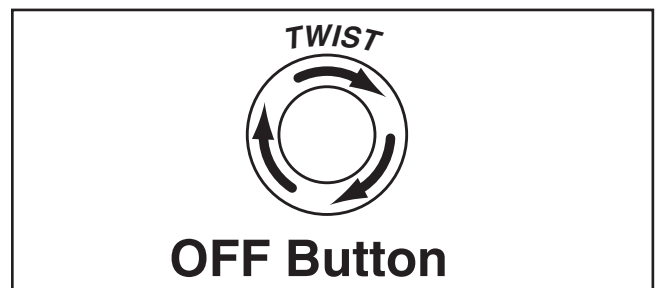

Figure 49. Resetting the switch.



7. Turn the bandsaw **ON** and allow it to reach full speed, then press the foot brake (**Figure 64** on **Page 38**) completely.

—If the bandsaw blade stops, the foot brake is working correctly; continue to the next step.

—If the bandsaw blade does not stop moving, the foot brake feature is not working correctly. This safety feature must work properly before proceeding with regular operations. Call Tech Support for help.

8. Close the upper and lower wheel covers.
9. Turn the switch disabling key to "0", as shown in **Figure 48** on **Page 30**.
10. Try to turn the machine **ON**.

—If the bandsaw does not start, the switch disabling feature is working as designed. The Test Run is complete.

—If the bandsaw starts, immediately disconnect power. The switch disabling feature is not working correctly. This safety feature must work properly before proceeding with regular operations. Call Tech Support for help.

11. **Model G0514X3 Only:** Verify that the power is not connected out of phase by starting/stopping the machine and determining if the motor turns in the correct direction, using the criteria below:

—If the blade moves down and toward the table (as standing in front of the machine), it is turning in the correct direction.

—If the blade turns up and away from the table, it is turning in the wrong direction. Stop the machine, disconnect the power source, then swap any two of the three power wires that connect to the machine.

Tensioning Blade

A properly tensioned blade is essential for making accurate cuts and is required before making many bandsaw adjustments. (Every time you replace the blade, you should perform this procedure because all blades tension differently.)

To tension the bandsaw blade:

1. Complete the **Test Run** procedure and make sure the blade is tracking properly.
2. Raise the upper blade guide assembly as high as it will go, and adjust the upper and lower guide blocks as far away from the blade as possible. **Note:** *This procedure will NOT work if the guide blocks have any contact with the blade.*
3. Engage the quick tension lever to the tightened position and turn the blade tension handwheel until the tension scale reads between 4 and 6.
4. Turn the bandsaw **ON**.
5. Slowly release the tension one quarter of a turn at a time. When you see the bandsaw blade start to flutter, stop decreasing the tension.
6. Now, slowly increase the tension until the blade stops fluttering, then tighten the tension another quarter turn.
7. Look at what the tension gauge reads and use that as a guide for tensioning that blade in the future. **Note:** *Always detension the blade after use to increase blade life and reduce strain on the bandsaw components.*
8. Re-adjust the blade tracking as instructed on **Page 23**.



Adjusting Support Bearings

The support bearings are positioned behind the blade for support during cutting operations. Proper adjustment of the support bearings is an important part of making accurate cuts and also keeps the blade teeth from coming in contact with the guide bearings while cutting.

NOTICE

Whenever changing a blade or adjusting tension and tracking, the upper and lower blade support bearings and blade guide bearings must be properly adjusted before performing cutting operations.

Adjusting Upper Support Bearings

1. DISCONNECT BANDSAW FROM POWER!
2. Make sure the blade is tracking properly and that it is correctly tensioned.
3. Familiarize yourself with the upper support bearing controls shown in **Figure 50**.

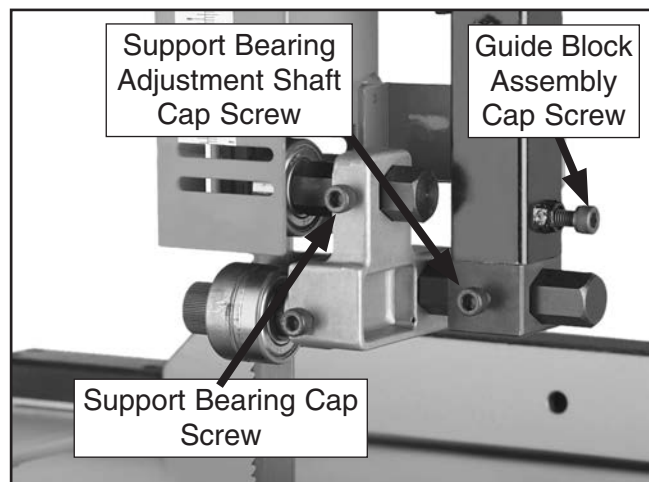

Figure 50. Upper support bearing controls.

4. Loosen the guide block assembly cap screw and rotate the blade guide assembly side-to-side, until the blade is perpendicular with the face of the support bearing, as illustrated in **Figure 51**.

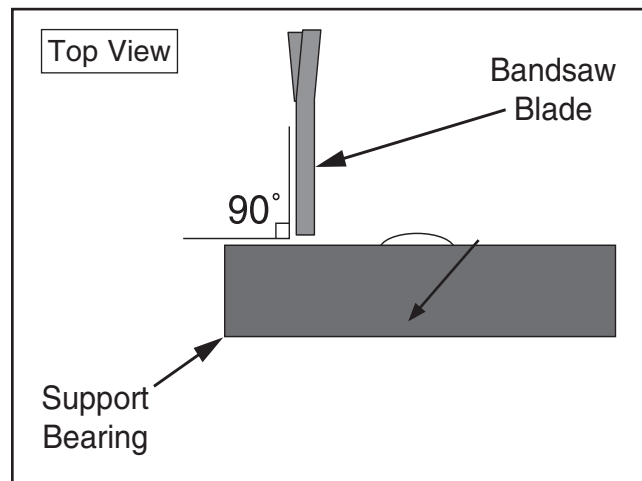

Figure 51. Blade should be perpendicular (90°) to the face of the support bearing.

5. Tighten the assembly cap screw.
6. Loosen the cap screw on the support bearing adjustment shaft.
7. Place a 0.016" feeler gauge between the support bearing and the blade, and position the bearing 0.016" away from the back of the blade, as illustrated in **Figure 52**.

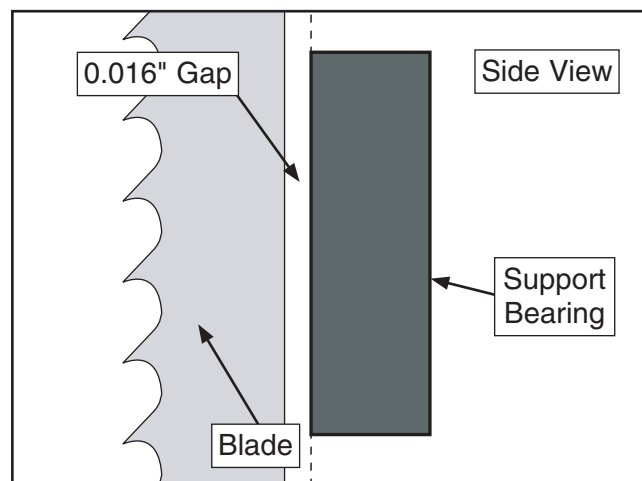

Figure 52. Blade should be aligned approximately 0.016" away from the bearing edge.



Note: For a quick gauge, fold a dollar bill in half twice (four thicknesses of a dollar bill is approximately 0.016") and place it between the support bearing and the blade, as shown in **Figure 53**.

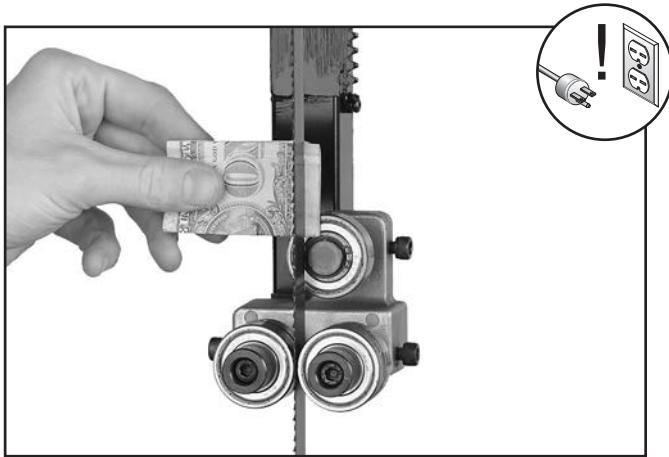

Figure 53. Dollar bill folded twice to make an approximate 0.016" gauge.

8. Tighten the cap screw to keep the support bearing locked in place.

Adjusting Lower Support Bearings

1. DISCONNECT BANDSAW FROM POWER!
2. Make sure that the blade is tracking properly and is correctly tensioned.
3. Familiarize yourself with the lower support bearing controls shown in **Figure 54**.

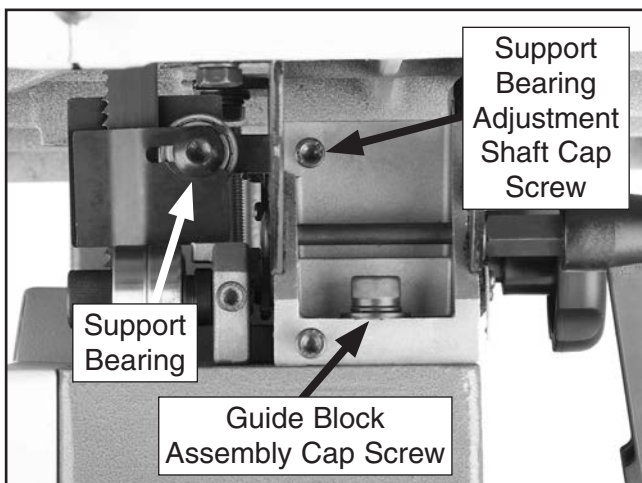

Figure 54. Lower support bearing controls.

4. Check to make sure the guide block assembly is perpendicular with the face of the support bearing as illustrated in **Figure 51**.

—If the guide block assembly is perpendicular to the face of the support bearing, continue on to the next step.

—If the guide block assembly is not perpendicular to the support bearing, loosen the guide block assembly cap screws and rotate the blade guide assembly side-to-side until the blade is perpendicular with the face of the support bearing, then retighten the cap screws. **Note:** The table must be re-aligned with the blade after the lower guide block assembly is adjusted. Refer to **Page 35**.

5. Loosen the cap screw on the support bearing adjustment shaft.
6. Place a 0.016" feeler gauge between the support bearing and the blade, and position the bearing 0.016" away from the back of the blade, as illustrated in **Figure 52**, or use a dollar bill, as shown in **Figure 53**.
7. Tighten the cap screw to keep the support bearing locked in place.

Adjusting Blade Guide Bearings

The blade guides provide side-to-side support to help keep the blade straight while cutting. The blade guides are designed to be adjusted in two ways—forward/backward and side-to-side.

To adjust the upper and lower blade guides:

1. Make sure the blade is tracking properly and that it is correctly tensioned.
2. DISCONNECT BANDSAW FROM POWER!



3. Familiarize yourself with the blade guide controls shown in **Figure 55**.

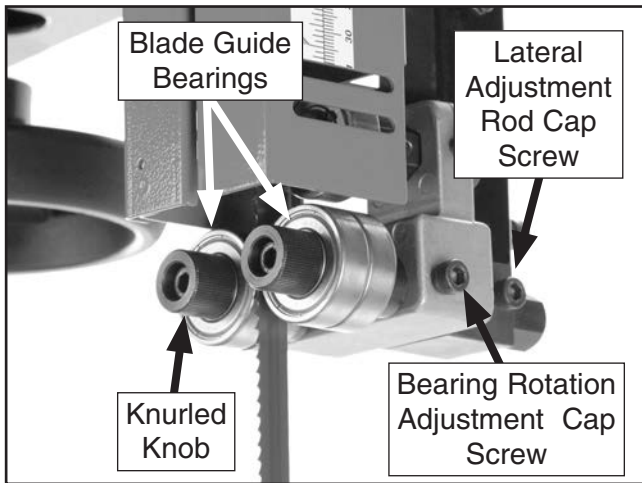

Figure 55. Blade guide controls.

4. Loosen the cap screw on the lateral adjustment rod and adjust the blade guides until the edges of the bearings are $\frac{1}{16}$ " behind the blade gullets, as illustrated in **Figure 56**.

Note: *The $\frac{1}{16}$ " spacing is ideal, although with larger blades it may not be possible. In such cases, adjust the guide bearings as far forward as possible to the blade gullets, and still maintain the proper support bearing spacing adjustment.*

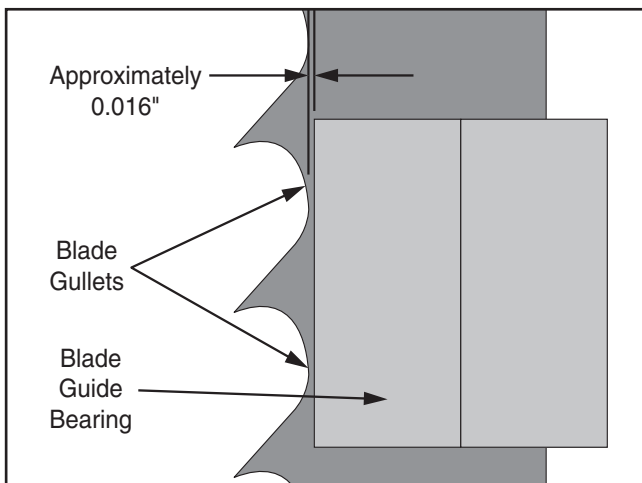

Figure 56. Lateral adjustment of blade guides.

NOTICE

Make sure that the blade teeth will not contact the guide bearings when the blade is against the rear support bearing during the cut or the blade teeth will be damaged.

5. Tighten the cap screw on the lateral adjustment rod.
6. Loosen the bearing rotation adjustment cap screws.
7. Rotate the knurled knob to position the bearings 0.004" away from the blade. **Note:** *0.004" is approximately the thickness of a dollar bill.*
8. Tighten the cap screw to lock the blade guide bearings in position.
9. Repeat this procedure for the lower guides.

NOTICE

Whenever changing a blade or adjusting tension and tracking, the upper and lower blade support bearings and guide bearings must be properly adjusted before cutting operations.



Aligning Table

To ensure cutting accuracy when the table is first installed, the table should be aligned so that the miter slot is parallel to the bandsaw blade. This procedure works best with a $\frac{3}{4}$ " blade installed.

To align the table so the miter slot is parallel to the bandsaw blade:

1. Make sure that the blade is tracking properly and that it is correctly tensioned.
2. DISCONNECT BANDSAW FROM POWER!
3. Loosen the trunnion bolts that secure the trunnions to the table.
4. Place an accurate straightedge along the blade. The straightedge should lightly touch both the front and back of the blade. **Note:** *Make sure the straightedge does not go across a tooth.*
5. Use a fine ruler to gauge the distance between the straightedge and the miter slot. The distance you measure should be the same at both the front and the back of the table (see **Figure 57**).
6. Adjust the table as needed for proper alignment.
7. Tighten the trunnion bolts.

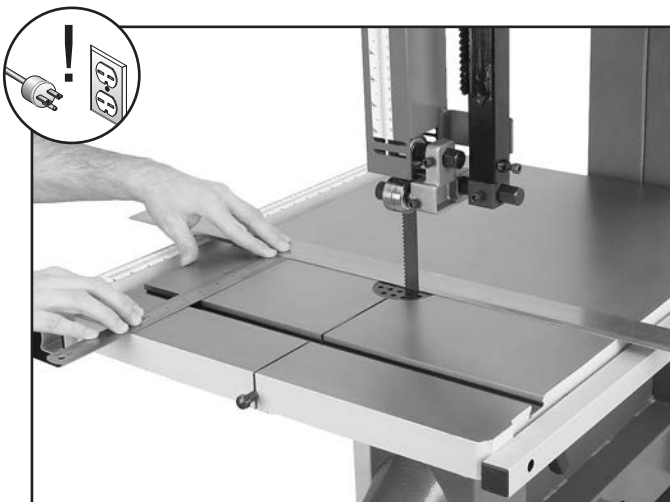

Figure 57. Measuring for miter slot to be parallel with blade.

Aligning Fence

To ensure cutting accuracy when the fence is first installed, the fence should be aligned with the miter slot.

To align the fence parallel with the miter slot:

1. DISCONNECT BANDSAW FROM POWER!
2. If the fence is mounted on the left-hand side of the blade, remove it and remount it next to the miter slot.
3. Loosen the four cap screws located on the top face of the fence (**Figure 58**).



Figure 58. Four fence cap screws.

4. Adjust the fence face parallel with the edge of the miter slot.
5. Tighten the four cap screws, being careful not to move the fence.

NOTICE

Adjusting the fence parallel to the miter slot does not guarantee straight cuts. The miter slot may need to be adjusted parallel to the side of the blade. Refer to the "Aligning Table" instructions on this page.



Fence Pointer Calibration

Your new bandsaw is equipped with a fence measurement system that includes a fence pointer, which must be calibrated when the bandsaw is first set up.

To calibrate the pointer:

1. DISCONNECT BANDSAW FROM POWER!
2. If the fence is mounted on the right-hand side of the blade, remove it and re-install it on the left-hand side of the blade.
3. Place the fence flush against the bandsaw blade (**Figure 59**).

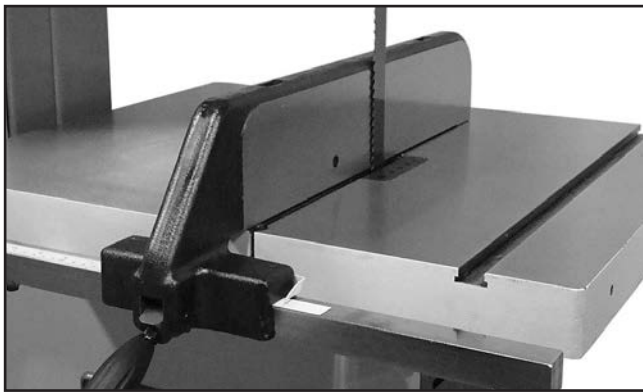

Figure 59. Fence flush with blade.

4. Loosen the pointer adjustment screw (**Figure 60**) and set the pointer in line with "0" on the measurement scale on the table.

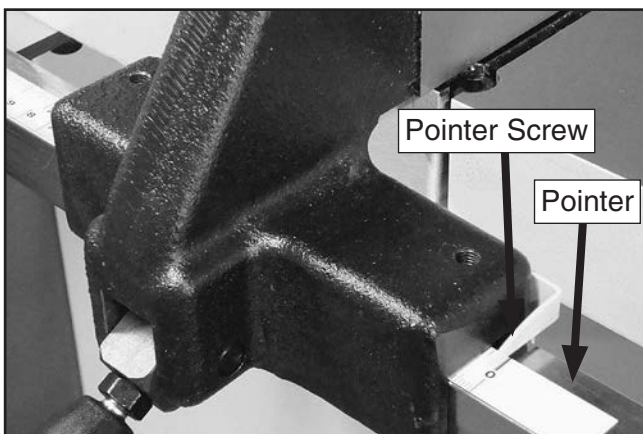

Figure 60. Calibrating fence pointer (adjustment screw out of view).

Miter Gauge

The miter gauge needs to be calibrated to the blade when it is first mounted in the miter slot.

To calibrate the miter gauge:

1. DISCONNECT BANDSAW FROM POWER!
2. Use a machinist's square with one edge against the face of the miter gauge and the other against the blade face as shown in **Figure 61**.

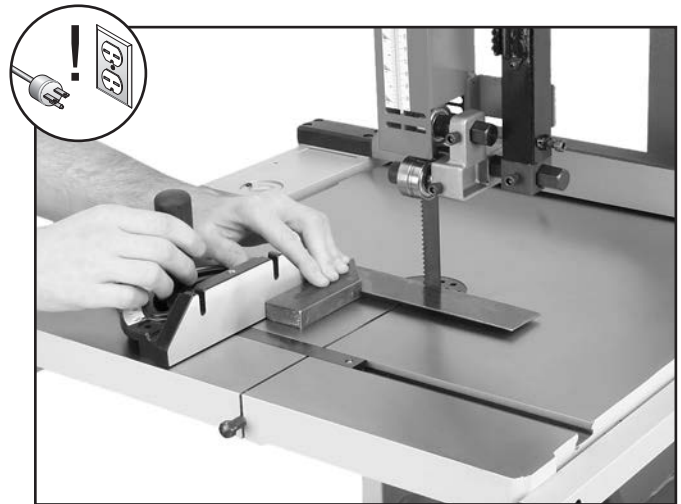

Figure 61. Squaring miter gauge to blade.

3. Loosen the lock knob on the miter gauge and adjust it flush with the edge of the square.
4. Tighten the lock knob, and verify the setting.

Note: Sometimes the tightening procedure can affect the adjustment.

5. Loosen the screw that secures the angle pointer and adjust the pointer to the 0° mark on the scale.
6. Retighten the screw that secures the angle pointer.



SECTION 4: OPERATIONS

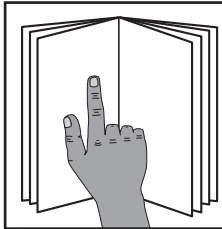

⚠️ WARNING

To reduce your risk of serious injury, read this entire manual **BEFORE** using machine.

⚠️ WARNING

Damage to your eyes and lungs could result from using this machine without proper protective gear. Always wear safety glasses and a respirator when operating this machine.

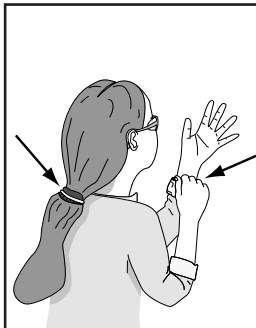

⚠️ WARNING

Loose hair, clothing, or jewelry could get caught in machinery and cause serious personal injury. Keep these items away from moving parts at all times to reduce this risk.

NOTICE

If you have never used this type of machine or equipment before, **WE STRONGLY RECOMMEND** that you read books, review industry trade magazines, or get formal training before beginning any projects. Regardless of the content in this section, Grizzly Industrial will not be held liable for accidents caused by lack of training.

Basic Controls

Refer to **Figures 62–66** and the following descriptions to become familiar with the basic controls and components of your bandsaw.

Power Switch: Disables the ON and OFF button when the key is turned to the "0" position. Enables ON and OFF button when key is turned to "1".

Switch Disabling Key: Disables the power switch and can be removed from the machine. Locking the switch in this manner can prevent unauthorized operation of the machine, which is especially important if the machine is not stored inside an access-restricted building

IMPORTANT: *Locking the power switch with the key only restricts its function. It is not a substitute for disconnecting power from the machine when adjusting or servicing.*

ON Button: Starts motor only if the OFF button is popped out and power switch key is turn to "1" position.

OFF Button: Disables the ON button. Enable the ON button by twisting the OFF button until it pops out.

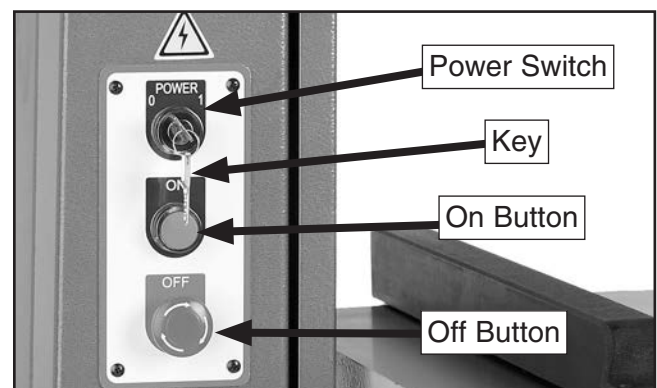

Figure 62. Control panel features.



Front Controls

- A. **Blade Tension Scale:** Allows for easy monitoring of blade tension.
- B. **Blade Tension Handwheel:** Tensions blade in gradual increments.
- C. **Blade Tracking Window:** Allows for easy monitoring of blade tracking (refer to **Page 23**).
- D. **Fence and Miter Gauge:** Allows for controlled straight or angle cutting.

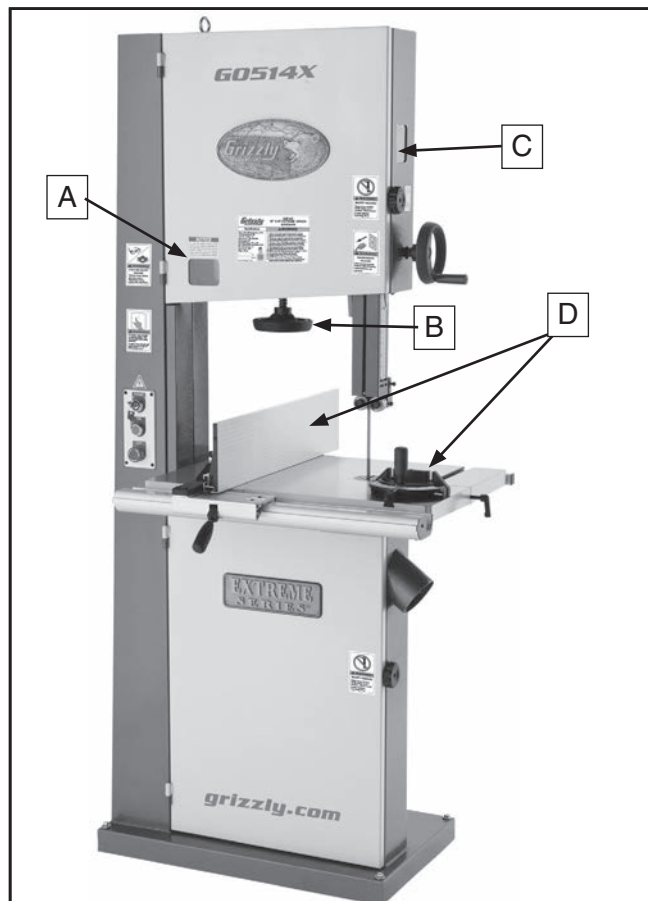

Figure 63. Front controls (G0514X).

- E. **Foot Brake (G0514X2 & G0514X3):** Cuts power to motor and allows bandsaw blade to be quickly brought to a stop.

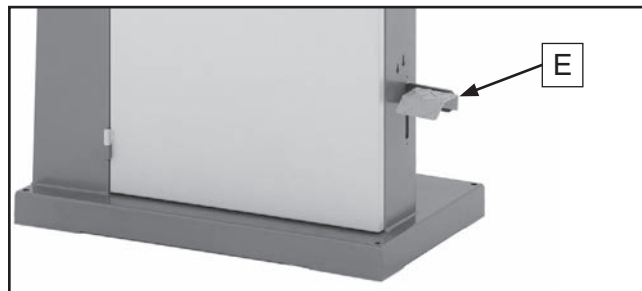

Figure 64. Foot brake.

Rear Controls

- F. **Guide Post Handwheel and Lock Knob:** Moves blade guide support quickly to the desired height on the guide post; locks setting (refer to **Page 42**).
- G. **Quick Release Blade Tension Lever:** Adjusts blade tension for quick blade changes.
- H. **Blade Tracking Knob and Lock Lever:** Moves and locks blade tracking.
- I. **Table Tilt Lock Levers (G0514X):** Locks or unlocks the table at the current angle.

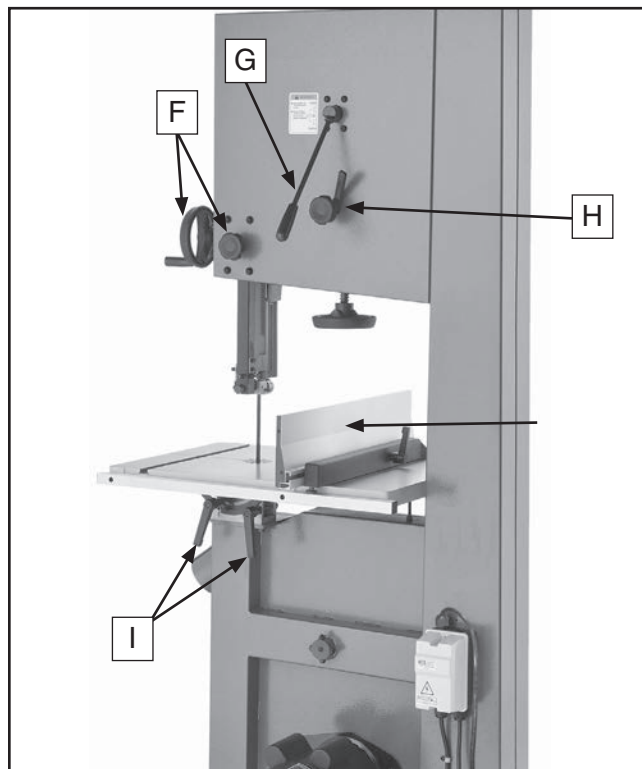

Figure 65. Rear controls (G0514X).



K. Table Tilt Lock Lever (G0514X2, G0514X2B, & G0514X3): Locks or unlocks the table at the current angle.

L. Table Tilt Handwheel (G0514X2, G0514X2B, & G0514X3): Tilts the table up to 5° to the left or 45° to the right (refer to **Page 42**).



Figure 66. Table tilt controls (G0514X2, G0514X2B, and G0514X3)

G0514X2B Motor Brake

The Model G0514X2B has a motor brake that activates and quickly stops the blade when the OFF button is pressed.

Operation Overview

This overview covers the basic process that happens during a bandsaw operation. Familiarize yourself with this process to better understand the remaining parts of the **Operation** section.

To complete a typical operation, the operator does the following:

1. Examines the workpiece to make sure it is suitable for cutting.
2. Adjusts the fence away from the blade the same width of the desired cut and then locks it in place.
3. Adjusts the blade tilt, if necessary, to the correct angle of the desired cut.
4. Adjusts the blade guide height to approximately 1" from the top of the workpiece.

5. Checks to make sure the workpiece can safely pass all the way through the blade without interference from other objects.

6. Puts on safety glasses.

7. Starts the dust collector and bandsaw.

8. Holds the workpiece firmly and flatly against both the table and fence, and then pushes the workpiece into the blade at a steady and controlled rate until the workpiece moves completely beyond the blade.

The operator is very careful to keep fingers away from the blade and uses a push stick to feed narrow workpieces.

9. Stops the bandsaw.

Basic Cutting Tips

Here are some basic tips to follow when operating the bandsaw:

- Keep the upper blade guide assembly adjusted to within 1" of the workpiece.
- Replace, sharpen, and clean blades as necessary. Make adjustments periodically to keep the saw running in top condition.
- Use light and even pressure while cutting. Light contact with the blade makes it easier to follow lines and prevents extra friction, which reduces blade life.
- Avoid twisting the blade when cutting around tight corners. Allow the blade to saw around the corners.
- Do not back the workpiece away from the blade while the saw is running.



Workpiece Inspection

Some wood workpieces are not safe to cut or may require modification before they are safe to cut.

Before cutting wood, get in the habit of inspecting all workpieces for the following:

- **Material Type:** This machine is intended for cutting natural and man-made wood products, and laminate covered wood products. Cutting drywall or cementitious backer board creates extremely fine dust, which may reduce the life of the bearings. This machine is NOT designed to cut metal, glass, stone, tile, etc.
- **Foreign Objects (Figure 67):** Nails, staples, dirt, rocks and other foreign objects are often embedded in wood. While cutting, these objects can become dislodged and hit the operator or break the blade, which might then fly apart. Always visually inspect your workpiece for these items. If they can't be removed, do NOT cut the workpiece.
- **Large/Loose Knots:** Loose knots can become dislodged during the cutting operation. Large knots can cause blade damage. Choose workpieces that do not have large/loose knots or plan ahead to avoid cutting through them.
- **Wet or "Green" Stock:** Cutting wood with a moisture content over 20% causes unnecessary wear on the blade and yields poor results.
- **Excessive Warping:** Workpieces with excessive cupping, bowing, or twisting are dangerous to cut because they are unstable and can move unpredictably when being cut. DO NOT cut excessively warped wood.
- **Minor Warping:** Workpieces with slight cupping can be safely supported if the cupped side faces the table or fence, as shown in **Figure 68**. On the contrary, a workpiece supported on the bowed side will rock during a cut, leading to loss of control.

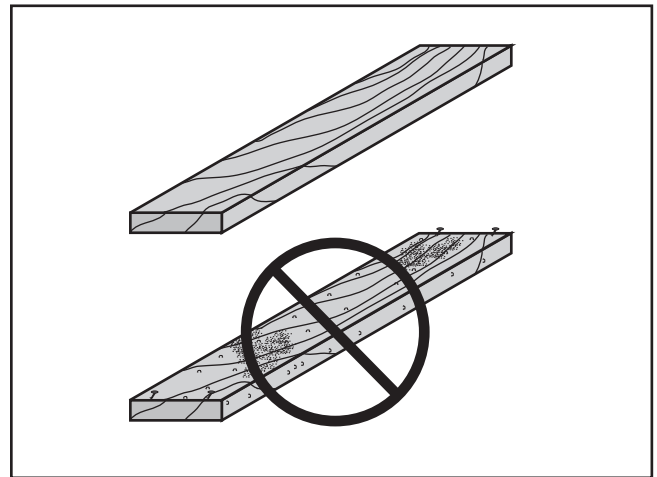

Figure 67. Choosing wood without foreign objects embedded.

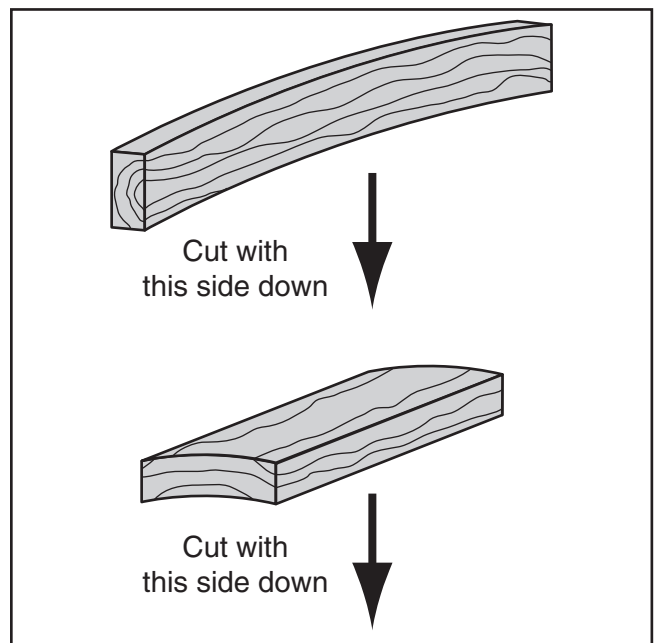

Figure 68. Cutting wood with minor warping.

WARNING

Because of its unpredictable nature, use extreme caution if cutting warped stock. The difference between acceptable and unacceptable warped stock varies from machine to machine. If you are in doubt, square-up the stock first or do not cut it.



Foot Brake

The Models G0514X2 and G0514X3 are equipped with a foot brake (**Figure 69**). Use the brake to cut power to the motor and bring the blade to a halt.



Figure 69. Foot brake.

NOTICE

The foot brake will not stop the bandsaw wheels and blade instantly. **DO NOT** become over confident and relax your safety awareness because of the foot brake feature. Make sure the bandsaw blade has stopped moving completely before leaving the machine.

Table Tilt

The bandsaw table will tilt 5° left and 45° right to provide a wide range of cutting options. Remove the positive stop bolt to tilt the table to the left.

G0514X Table Tilt

1. **DISCONNECT BANDSAW FROM POWER!**
2. Loosen the lock handle on the table trunnion, shown in **Figure 70**.

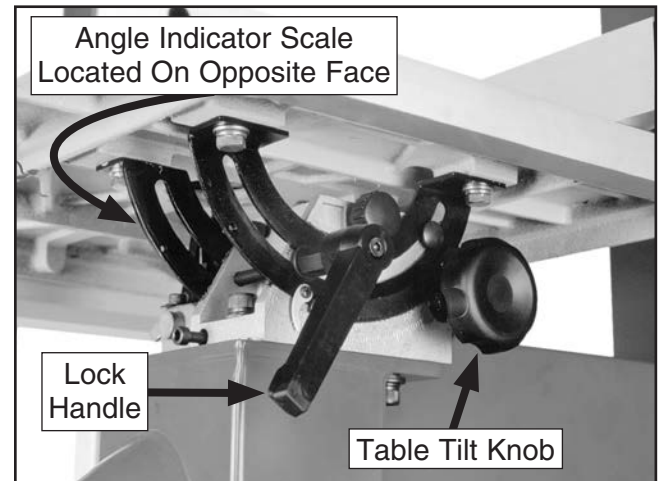

Figure 70. G0514X Table tilt controls.

3. Turn the table tilt knob to position the table to the desired angle of tilt. Refer to the angle gauge on the front table trunnion for the tilting angle.
4. To tilt the table to the left, turn the table tilt knob clockwise one turn, remove or lower the positive stop bolt, then turn the tilt knob counterclockwise.
5. Retighten the lock handle to secure the table.
6. Follow **Positive Stop** instructions on **Page 25** for resetting the stop bolt and table for horizontal (0°) operations.



G0514X2, G0514X2B, & G0514X3 Table Tilt

1. DISCONNECT BANDSAW FROM POWER!
2. Loosen the table tilt lock lever shown in **Figure 71**.

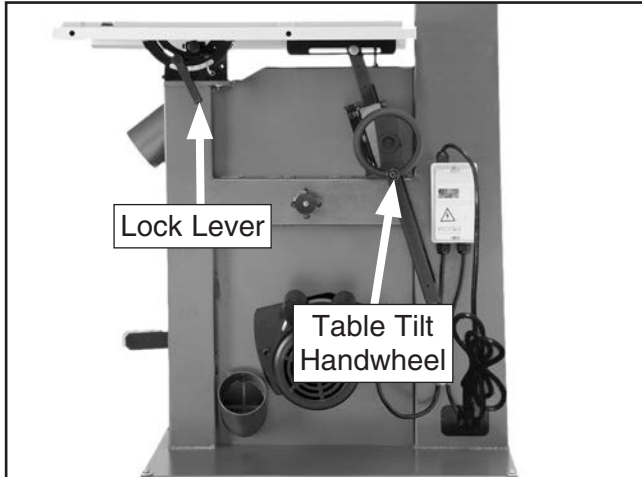

Figure 71. G0514X2, G0514X2B, and G0514X3 table tilt controls.

3. To tilt the table to the right, turn the table tilt handwheel clockwise (**Figure 71**).
4. To tilt the table to the left, turn the table tilt handwheel clockwise one turn, lower the positive stop bolt, then turn the handwheel counterclockwise.
5. Secure the table tilt lock lever (**Figure 71**).
6. Follow "Positive Stop" instructions on **Page 25** for resetting the stop bolt and table for horizontal (0°) operations.

Guide Post

The guide post, shown in **Figure 72**, connects the upper blade guide assembly to the bandsaw. The guidepost allows the blade guide assembly to move up or down to be as close to the workpiece as possible. In order to cut accurately and safely, the bottom of the blade guide assembly must be no more than 1" above the workpiece at all times—this positioning provides the greatest blade support and minimizes the amount of moving blade exposed to the operator.

To adjust the blade guide assembly on the guide post:

1. DISCONNECT BANDSAW FROM POWER!
2. Make sure that the blade tension, blade tracking, support bearings, and blade guides are adjusted correctly.
3. Loosen the guide post lock knob shown in **Figure 72**.

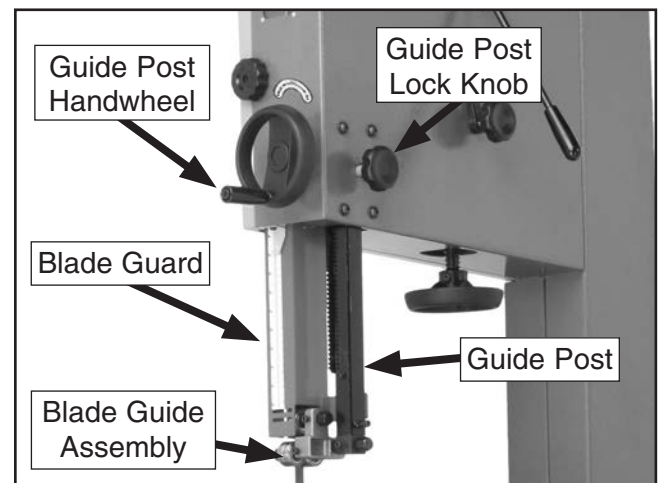

Figure 72. Guide post controls.

4. Turn the guide post handwheel to raise or lower the guide post until the upper blade guide assembly is within 1" from the top of the workpiece.
5. Lock the guide post in place with the lock knob.



Fine Tune Tracking

To fine tune the tracking:

1. Close the wheel covers and turn the bandsaw **ON**.
2. Observe the blade tracking path through the clear window on the right edge of the bandsaw as shown in **Figure 73**.

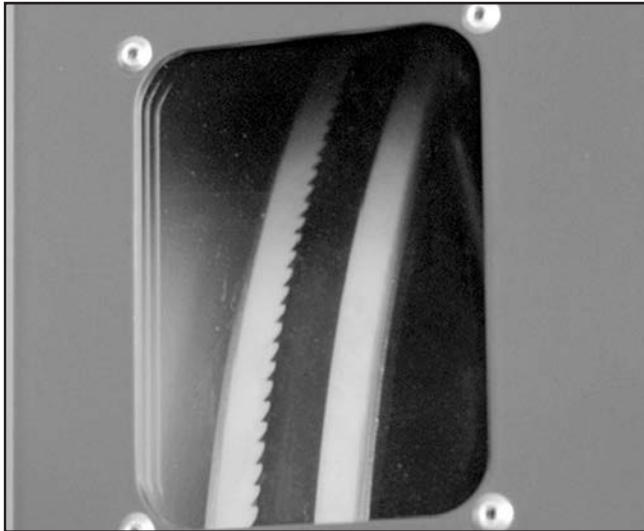

Figure 73. Blade tracking window.

3. Using the tracking controls (**Page 24, Figure 31**), adjust the blade so it tracks on the center of the wheel.
4. Tighten the tracking lock so the knob cannot move.

Ripping

Ripping is the process of cutting with the grain of the wood stock. For plywood and other processed wood, ripping simply means cutting down the length of the workpiece.

To make a rip cut:

1. Adjust the fence to match the width of the cut on your workpiece and lock the fence in place.
2. Adjust the blade guide assembly to the correct height.
3. After all safety precautions have been met, turn the bandsaw **ON**. Slowly feed the workpiece into the blade and continue with the cut until the blade is completely through the workpiece. **Figure 74** shows a typical ripping operation. **Note:** *If you are cutting narrow pieces, use a push stick to protect your fingers.*



Figure 74. Ripping with a push stick.

⚠️ WARNING

NEVER place fingers or hands in the line of cut. In the event that something unexpected happens, your hands or fingers may be pulled into the blade. **ALWAYS** use a push stick when ripping narrow pieces. Failure to follow these warnings may result in serious personal injury!



Crosscutting

Crosscutting is the process of cutting across the grain of wood. For plywood and other processed wood, crosscutting simply means cutting across the width of the material.

To make a 90° crosscut:

1. Mark the workpiece on the edge where you want to begin the cut.
2. Adjust the blade guide assembly to the correct height and make sure the miter gauge is set to 90°.
3. Move the fence out of the way. Place the workpiece evenly against the miter gauge.
4. Hold the workpiece against the miter gauge and line up the mark with the blade.
5. After all safety precautions have been met, turn the bandsaw **ON**. Slowly feed the workpiece into the blade and continue the cut until the blade is all the way through the workpiece. **Figure 75** shows a typical crosscutting operation.

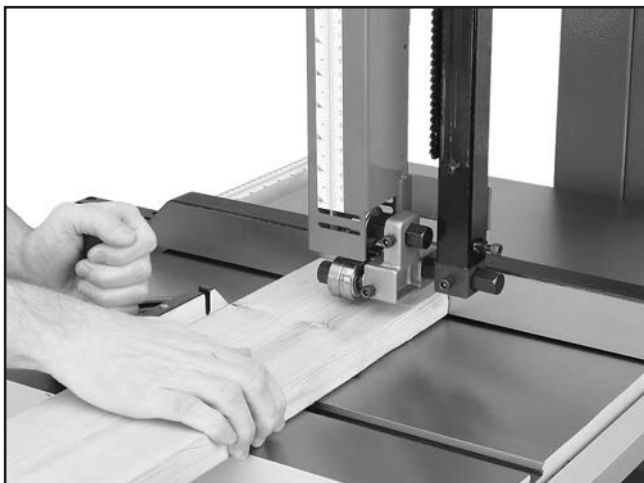

Figure 75. Crosscutting with miter gauge.

Resawing

Resawing (**Figure 76**) is the process of cutting a board into two or more thinner boards. The maximum board width that can be resawn is limited by the maximum cutting height of the bandsaw.

One of the most important considerations when resawing is blade selection. Generally, the wider blade, the better. In most applications, a hook or a skip tooth style will be desirable. Choose blades with fewer teeth-per-inch (from 3 to 6), because they offer larger gullet capacities for clearing sawdust, reducing heat buildup and reducing strain on the motor.



Figure 76. Resawing lumber.

⚠️ WARNING

When resawing thin pieces, a wandering blade (blade lead) can tear through the surface of the workpiece, exposing your hands to the blade teeth. Always use push blocks when resawing and keep your hands clear of the blade.



To resaw a workpiece:

1. Verify that the bandsaw is setup properly and that the table is perpendicular to the blade.
2. Use the widest blade your bandsaw will accept. **Note:** *The blade must also be sharp and clean.*
3. Install the resaw fence and set it to the desired width of cut and lock it in place.

NOTICE

The scale on the front rail will NOT be accurate when using the resaw fence.

4. Support the ends of the board if necessary.
5. Turn the bandsaw **ON**.
6. Using push paddles and a push stick, keep pressure against the fence and table, and slowly feed the workpiece into the moving blade until the blade is completely through the workpiece (see **Figure 76**).

Cutting Curves

When cutting curves, simultaneously feed and turn the stock carefully so that the blade follows the layout line without twisting. If a curve is so abrupt that it is necessary to repeatedly back up and cut a new kerf, use either a narrower blade or a blade with more TPI (teeth per inch), or make more relief cuts.

Always make short cuts first, then proceed to the longer cuts. Relief cuts will also reduce the chance that the blade will be pinched or twisted. Relief cuts are cuts made through the waste portion of the workpiece and are stopped at the layout line. As you cut along the layout line, waste wood is released from the workpiece, alleviating any pressure on the back of the blade. Relief cuts also make backing the workpiece out easier, if needed.

NOTICE

The list below displays blade widths and the corresponding minimum radii for those blade widths.

Width	Radius
1/8"	1/8"
3/16"	3/8"
1/4"	5/8"
3/8"	1 1/4"
1/2"	2 1/2"
5/8"	3 3/4"
3/4"	5 1/2"



Stacked Cuts

One of the benefits of a bandsaw is its ability to cut multiple copies of a particular shape by stacking a number of workpieces together. Before making stacked cuts, ensure that both the table and the blade are properly adjusted to 90°. Otherwise, any error will be compounded.

To complete a stacked cut:

1. Align your pieces from top to bottom to ensure that each piece has adequate scrap to provide a clean, unhampered cut.
2. Secure all the pieces together in a manner that will not interfere with the cutting. Hot glue on the edges works well, as do brad nails through the waste portion. (Be careful not to cut into the brads or you may break the blade!)
3. On the face of the top piece, lay out the shape you intend to cut.
4. Make relief cuts perpendicular to the outline of your intended shape in areas where changes in blade direction could strain the woodgrain or cause the blade kerf to bind.
5. Cut the stack of pieces as though you were cutting a single piece. Follow your layout line with the blade kerf on the waste side of your line as shown in **Figure 77**.

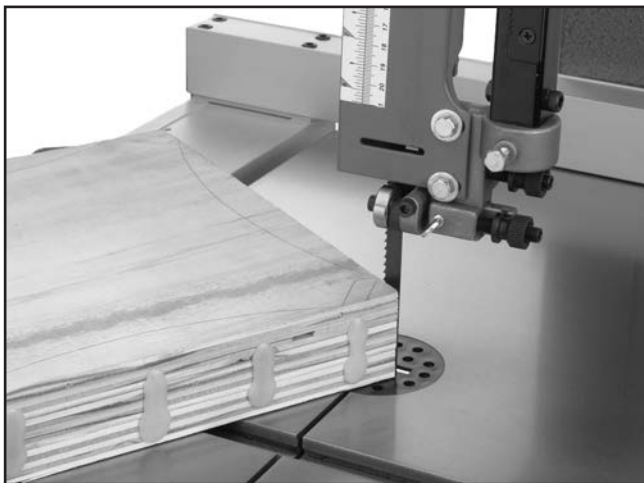

Figure 77. Typical stacked cut.

Blade Speed

The blade speed can be adjusted to 1700 or 3500 FPM. Speed adjustments are made by moving the V-belt position on the motor and wheel pulleys.

Most woodcutting can be performed successfully at the higher blade speeds. Slower blade speeds generally produce better results when cutting hardwoods, intricate curves, or when an exceptionally smooth cut is desired.

To adjust the blade speed:

1. DISCONNECT BANDSAW FROM POWER!
2. Loosen the motor mount cap screws shown in **Figure 78** and rotate the motor to loosen the V-belt.



Figure 78. Motor mount cap screws.



3. Refer to **Figure 79** to locate the correct V-belt position for the desired blade speed.

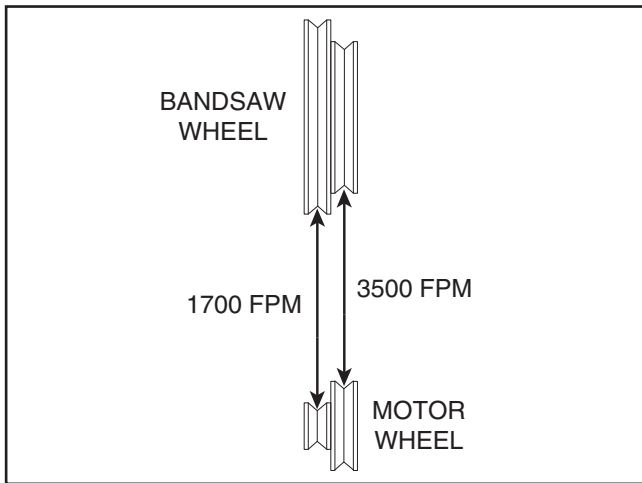

Figure 79. V-belt speeds.

4. Move the V-belt to the desired pulley.
5. Rotate the motor to tension the V-belt, then tighten the motor mount cap screws.
6. Check the V-belt tension. When tensioned correctly, the V-belt can be deflected approximately $\frac{3}{4}$ " (see **Figure 80**).

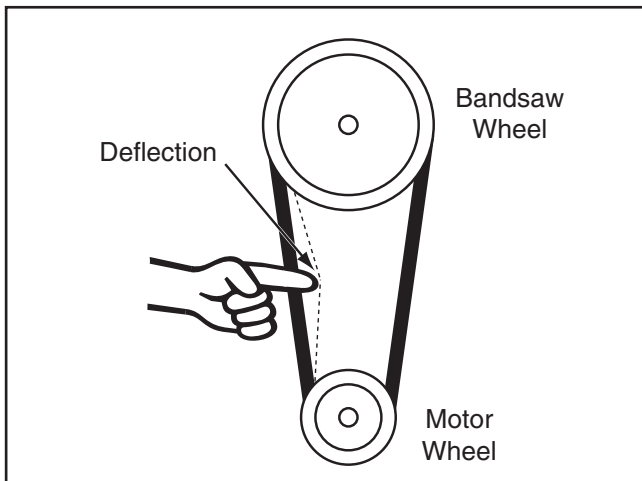

Figure 80. V-belt deflection.

Blade Information

Selecting the right blade requires a knowledge of the various blade characteristics to match the blade with the particular cutting operation.

Blade Length

Measured by the circumference, blade lengths are usually unique to the brand of your bandsaw and the distance between wheels. This bandsaw is designed for blades that are 143" long. Refer to **Page 50** for blade replacements.

Blade Width

Measured from the back of the blade to the tip of the blade tooth (the widest point), blade width is often the first consideration given to blade selection. Blade width dictates the largest and smallest curve that can be cut, as well as how accurately it can cut a straight line.

The Model G0514X/G0514X3 can use blades from $\frac{1}{8}$ " to $1\frac{1}{4}$ " in width. Always pick the size of blade that best suits your application.

- **Curve Cutting:** Use the chart in **Figure 81** to determine the correct blade for curve cutting. Determine the smallest radius curve that will be cut on your workpiece and use the corresponding blade width.

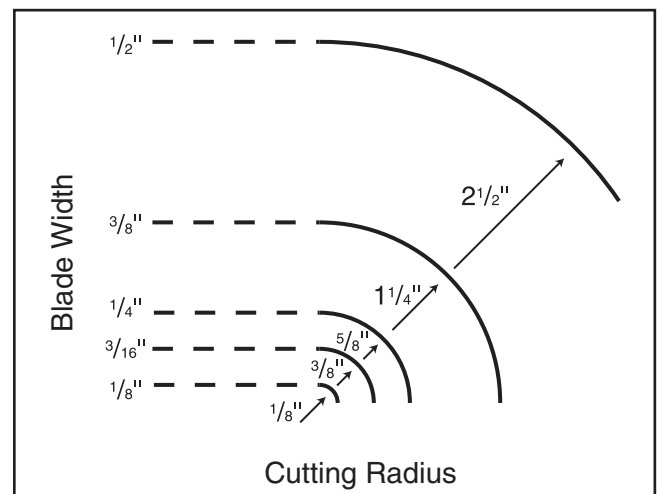

Figure 81. Blade width radii.



- **Straight Cutting:** Use the largest width blade that you own. Narrow blades can cut tight curves (a small radius) but are not very good at cutting straight lines because they naturally wander (blade lead). However, larger blades are much better at cutting straight lines, but function poorly at cutting small curves because of their size.

Tooth Style

When selecting blades, another option to consider is the shape, gullet size, teeth set and teeth angle—otherwise known as “Tooth Style.” **Figure 82** shows the three main categories of tooth style:

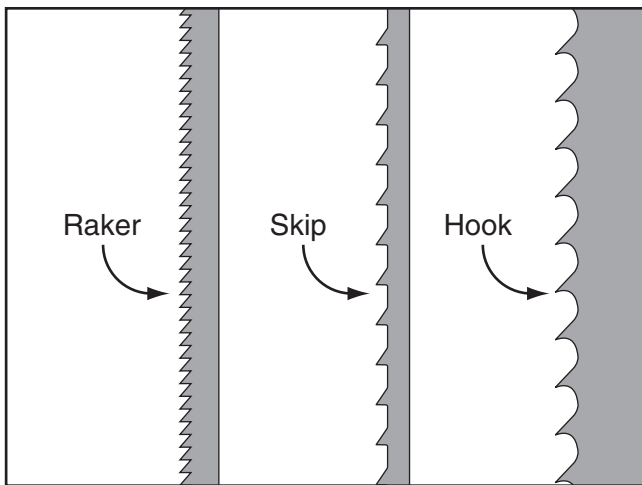

Figure 82. Raker, skip & hook tooth styles.

- **Raker:** This style is considered to be the standard because the tooth size and shape are the same as the tooth gullet. The teeth on Raker blades usually are very numerous, have no angle, and produce cuts by scraping the material; these characteristics result in very smooth cuts, but do not cut fast and generate more heat while cutting.
- **Skip:** This style is similar to a raker blade that is missing every other tooth. Because of the design, skip toothed blades have a much larger gullet than raker blades, and therefore, cut faster and generate more heat. However, these blades also leave a rougher cut than raker blades.

- **Hook:** The teeth on this style have a positive angle (downward) which makes them dig into the material, and the gullets are usually rounded for easier waste removal. These blades are excellent for the tough demands of resawing and ripping thick material.

Tooth Pitch

Usually measured as TPI (teeth per inch), tooth pitch determines the size of the teeth. More teeth per inch (fine pitch) will cut slower, but smoother; while fewer teeth per inch (coarse pitch) will cut rougher, but faster. As a general rule, choose blades that will have at least three teeth in the material at all times. Use fine pitched blades on harder woods and coarse pitched blades on softer woods.

Blade Care

A bandsaw blade is a delicate piece of steel that is subjected to tremendous strain. You can obtain longer use from a bandsaw blade if you give it fair treatment and always use the appropriate feed rate for your operation.

Be sure to select blades with the proper width, style, and pitch for each application. The wrong choice of blades will often produce unnecessary heat which will shorten the life of your blade.

A clean blade will perform much better than a dirty blade. Dirty or gummed up blades pass through the cutting material with much more resistance than clean blades. This extra resistance also causes unnecessary heat.

Blade Breakage

Many conditions may cause a bandsaw blade to break. Blade breakage is unavoidable, in some cases, since it is the natural result of the peculiar stresses that bandsaw blades are subjected to. Blade breakage is also due to avoidable circumstances. Avoidable breakage is most often the result of poor care or judgement on the part of the operator when mounting or adjusting the blade or support guides.



The most common causes of blade breakage are:

- Faulty alignment and adjustment of the guides.
- Forcing or twisting a wide blade around a curve of short radius.
- Feeding the workpiece into the blade too fast.
- Tooth dullness or absence of sufficient set.
- Incorrect tension.
- Top blade guide assembly set too high above the workpiece.
- Using a blade with a lumpy or improperly finished braze or weld.
- Continuously running the bandsaw when not in use.

Blade Changes

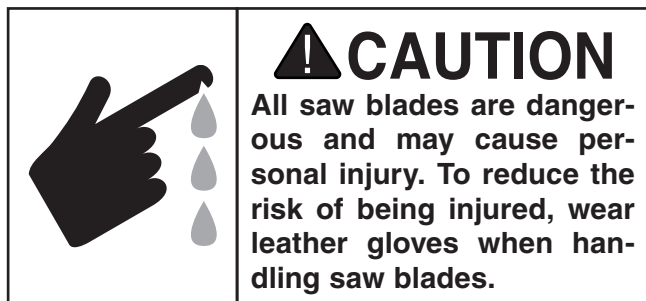

Removing Blade

1. DISCONNECT BANDSAW FROM POWER!
2. Release the blade tension by turning the blade tension quick release lever to the left.
3. Remove the table insert and the table pin. Adjust the upper and lower guide bearings as far away as possible from the blade.
4. Open the upper and lower wheel covers, and with gloved hands, slide the blade off of both wheels.

5. Rotate the blade 90° and slide it through the slot in the table.

Installing Blade

1. DISCONNECT BANDSAW FROM POWER!
2. Slide the blade through the table slot, ensuring that the teeth are pointing down toward the table. **Note:** *If the teeth will not point downward in any orientation, the blade is inside-out. Put on heavy gloves, remove the blade, and twist it right side-out.*
3. Slip the blade through the guides, and mount it on the upper and lower wheels (**Figure 83**).

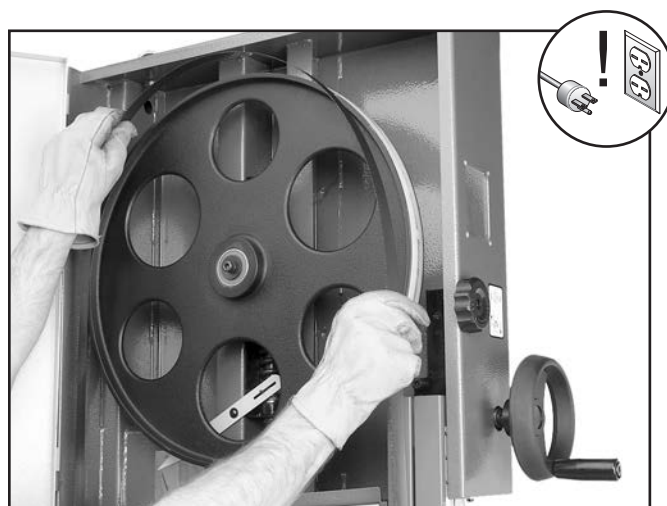

Figure 83. Placing blade on the wheels.

4. Tighten the blade tension lever.
5. Apply tension to the blade by turning the tension control knob. Rotate the upper wheel slowly by hand as tension is applied to allow the blade to center itself on the wheel. Adjust tracking if needed.
6. Adjust tension as described **Page 31**.
7. Adjust the upper/lower guide bearings and the support bearings.
8. Close the wheel covers.
9. Replace the table insert and table pin.



SECTION 5: ACCESSORIES

⚠️ WARNING

Some aftermarket accessories can be installed on this machine that could cause it to function improperly, increasing the risk of serious personal injury. To minimize this risk, only install accessories recommended for this machine by Grizzly.

NOTICE

Refer to the newest copy of the Grizzly Catalog for other accessories available for this machine.

143" Carbon Steel Replacement Blades

MODEL	WIDTH	TPI
H4826	1/8"	14 RAKER
H4827	1/4"	6 HOOK
H4828	1/4"	18 RAKER
H4829	3/8"	10 RAKER
H4830	1/2"	6 HOOK
H4831	1/2"	10 RAKER
H4832	3/4"	3 HOOK
H4833	1"	6 HOOK
H4834	1"	2 HOOK
H4835	1 1/4"	1.3 HOOK

G1163P—1HP Dust Collector

Effective dust collection not only keeps your shop cleaner and more pleasant to work in, it can also keep you healthier. Our systems feature powerful motors and convenient collection bags - so they're ideal for just about any-sized woodworking operation.



Figure 84. G1163P 1HP dust collector.

D2058A—Super Heavy-Duty SHOP FOX® Mobile Base

This patented, super heavy-duty mobile machine base is the strongest mobile base on the market. 18" x 24 1/2" minimum and adjusts to 28 1/2" x 33 1/2" maximum. 1200 lb. capacity. This base is extremely stable with outrigger type supports and a four wheel system. Weighs 38 lbs.



Figure 85. D2058A SHOP FOX® Mobile Base.

G5562—SLIPIT® 1 Qt. Gel

G5563—SLIPIT® 12 Oz. Spray

G2871—Boeshield® T-9 12 Oz. Spray

G2870—Boeshield® T-9 4 Oz. Spray

H3788—G96® Gun Treatment 12 Oz. Spray

H3789—G96® Gun Treatment 4.5 Oz. Spray



Figure 86. Recommended products for protecting unpainted cast iron/steel on machinery.

order online at www.grizzly.com or call 1-800-523-4777



SHOP FOX® Roller Stands
D2273—Single Roller Stand

Adjusts from 26⁵/₈" to 45".

D2274—5 Roller Stand

Adjusts from 26" to 44⁵/₈".

These super heavy-duty roller stands feature convenient hand knobs for fast height adjustment. Invaluable for support work on machines of various heights.



Figure 87. SHOP FOX® Roller Stands

Basic Eye Protection

T20501—Face Shield Crown Protector 4"

T20502—Face Shield Crown Protector 7"

T20503—Face Shield Window

T20451—"Kirova" Clear Safety Glasses

T20456—DAKURA Safety Glasses, Black/Clear

T28175—R3 SAFETY Stealth Safety Glasses



Figure 88. Assortment of basic eye protection.

T10117—Big Mouth Dust Hood with Stand

Capture dust from any machine operation with this Big Mouth Dust Hood. Simply attach a 4" dust collection hose and adjust the hood right where you need it. The free standing base eliminates complicated machine set-ups and the tilting 16³/₈" x 12⁷/₈" hood adjusts from 23" to 43" high. Every shop needs one of these!



Figure 89. T10117 Big Mouth Dust Hood.

T26419—NLGI#2 Syn-O-Gen Synthetic Grease

Formulated with 100% pure synthesized hydrocarbon basestocks that are compounded with special thickeners and additives to make Syn-O-Gen non-melt, tacky, and water resistant. Extremely low pour point, extremely high temperature oxidation, and thermal stability produce a grease that is unmatched in performance.

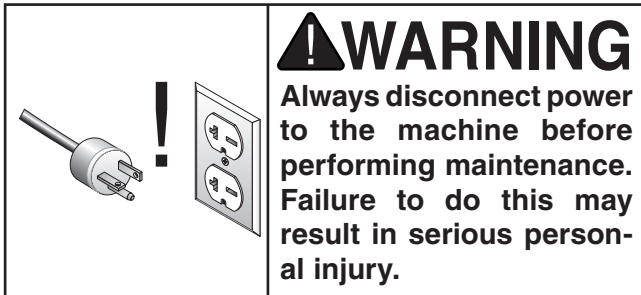

Figure 90. T26419 Syn-O-Gen Synthetic Grease.

order online at www.grizzly.com or call 1-800-523-4777



SECTION 6: MAINTENANCE



Schedule

For optimum performance from your machine, follow this maintenance schedule and refer to any specific instructions given in this section.

Daily Check:

- Loose mounting bolts.
- Damaged saw blade.
- Worn or damaged wires.
- Any other unsafe condition.

Monthly Check:

- V-belt tension, damage, or wear.
- Clean/vacuum dust buildup from inside cabinet and off motor.

Cleaning

Cleaning the bandsaw is relatively easy. Vacuum excess wood chips and sawdust, and wipe off the remaining dust with a dry cloth. If any resin has built up, use a resin dissolving cleaner to remove it. Treat all unpainted cast iron and steel with a non-staining lubricant after cleaning.

Unpainted Cast Iron

Protect the unpainted cast iron surfaces on the table by wiping the table clean after every use—this ensures moisture from wood dust does not remain on bare metal surfaces.

Keep tables rust-free with regular applications of products like G96® Gun Treatment, SLIPIT®, or Boeshield® T-9 (see **Section 5: Accessories** on **Page 50** for more details).

Brushes

The bandsaw is equipped with two lower brushes. The brushes should be checked daily and cleaned when they become dirty. There are adjustment brackets that allow the brushes to be adjusted for bristle wear. Refer to **Adjusting Wheel and Blade Brushes** on **Page 62** for adjustment details.

Lubrication

Since all bearings are sealed and permanently lubricated, simply leave them alone until they need to be replaced. Do not lubricated them.

This machine does need lubrication in other places. An essential part of lubrication is cleaning the components before lubricating them.

This step is critical because dust and chips build up on lubricated components, which makes them hard to move. Simply adding more grease to built-up grime will not result in smooth moving parts.

Clean the components in this section with an oil/grease solvent cleaner.



Blade Guide Rack & Pinion

Lubrication TypeNLGI#2 Grease or Equivalent
Amount Thin Coat
Frequency.....As Needed

To lubricate the blade guide rack and pinion:

1. DISCONNECT BANDSAW FROM POWER!
2. Lower the blade guide until it reaches the table.
3. Using a rag and mineral spirits, wipe off any existing grease and sawdust buildup on the rack (see **Figure 91**).

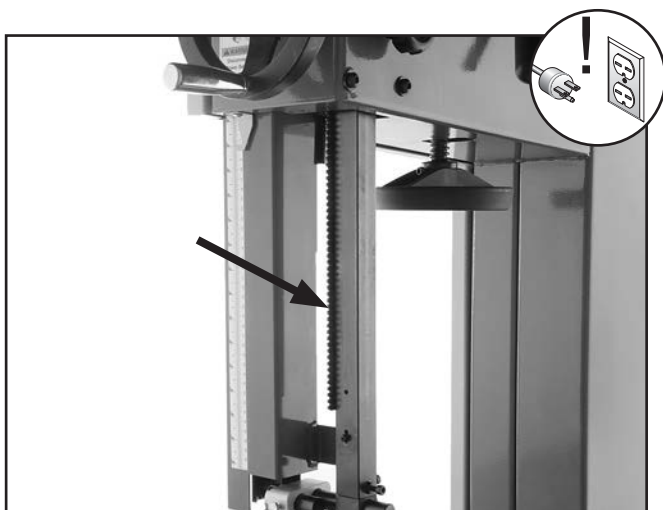

Figure 91. Example of rack lubrication location.

4. Apply a thin coat of NLGI#2 grease to the rack.
5. Move the blade guide up and down several times and remove any excess grease to help prevent sawdust buildup.

Tension Adjustment Assembly

Lubrication TypeNLGI#2 Grease or Equivalent
Amount Thin Coat
Frequency.....As Needed

To lubricate the tension adjustment assembly:

1. DISCONNECT BANDSAW FROM POWER!
2. Open the top wheel cover and look through the top of the wheel.
3. Using a rag and mineral spirits, wipe off any existing grease and sawdust buildup on the blade tension adjustment assembly and tension lever cam.
4. Apply a thin coat of NLGI#2 grease to the tension adjustment assembly and tension lever cam (see **Figure 92**).

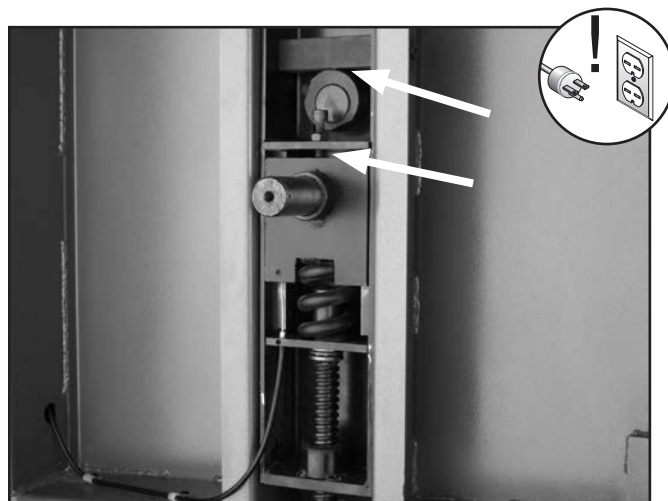

Figure 92. Example of tension adjustment assembly locations (top wheel removed for clarity).



Table Tilt Rack and Pinion Assembly (G0514X2, G0514X2B, & G0514X3)

Lubrication TypeNLGI#2 Grease or Equivalent
Amount Thin Coat
Frequency.....As Needed

To lubricate the table tilt rack and pinion assembly:

1. DISCONNECT BANDSAW FROM POWER!
2. With the table perpendicular to the blade, and using a rag and mineral spirits, wipe off all existing grease and sawdust buildup from the rack.
3. Move the table up to its maximum 45° angle and wipe (**Figure 93**) off all existing grease and sawdust buildup from the rack.



Figure 93. Example of lubricating table tilt rack and pinion assembly.

4. Apply a thin coat of NLGI#2 grease to the rack.
5. Move the table up and down several times to distribute the grease, then wipe off any excess grease.

Trunnions

Model G0514X has a steel trunnion that can be cleaned and lubricated with NLGI#2 Grease or equivalent along the sliding surfaces (see **Figure 94**).

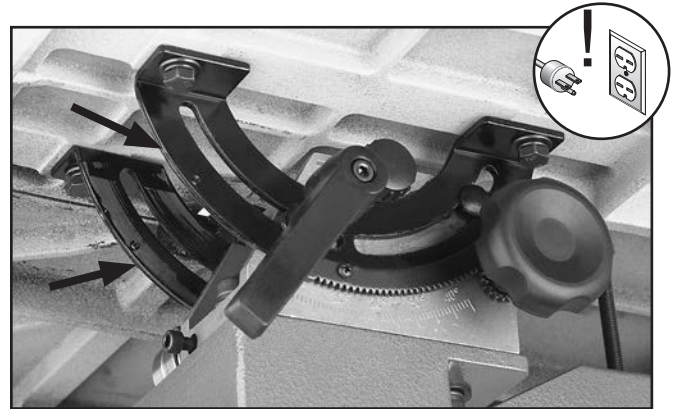

Figure 94. Trunnion lubrication location (G0514X).

Models G0514X2, G0514X2B, and G0514X3 have cast iron trunnions that produce a fine graphite powder over time that acts as a lubricant. We recommend not adding lubricant to the trunnions which could make a sticky substance that would prevent smooth movement.

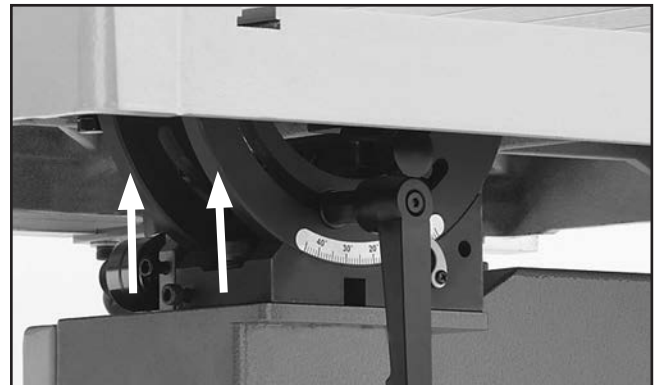

Figure 95. Trunnion lubrication location (G0514X2/G0514X2B/G0514X3).



SECTION 7: SERVICE

Review the troubleshooting procedures in this section if a problem develops with your machine. If you need replacement parts or additional help with a procedure, call our Technical Support. **Note:** *Please gather the serial number and manufacture date of your machine before calling.*

Troubleshooting



Symptom	Possible Cause	Possible Solution
Machine does not start or a breaker trips.	<ol style="list-style-type: none"> Emergency stop button engaged/at fault. Switch disabling key removed. Door safety switch disengaged/at fault. Thermal overload relay in mag switch tripped. Break or short in wiring; or loose or corroded connections. Plug or receptacle is corroded or miswired. Power supply switched off/has incorrect voltage. Motor connection wired incorrectly. Contactors has poor contacts or is at fault. Blown fuse/tripped circuit breaker. Motor ON/OFF switch at fault. Start capacitor has blown. Centrifugal switch at fault. Motor at fault. 	<ol style="list-style-type: none"> Rotate button to reset/replace button. Reinstall switch disabling key. Close door or adjust/replace switch. Allow relay/motor to cool. If necessary, press reset button inside switch. Trace/replace broken or corroded wires; fix loose connections. Correct the wiring. Switch power supply on/verify voltage. Wire motor correctly. Refer to inside junction box cover or Page 69 (G0514X), Page 70 (G0514X2), Page 71 (G0514X2B), or Page 72 (G0514X3). Test all legs for power, test field coil, and fix contacts or replace if at fault. Replace/reset fuse or circuit breaker. Repair possible short or circuit overload. Replace switch. Test/replace if at fault. Adjust/replace centrifugal switch. Test for shorted windings or bad bearings; repair or replace.
Main motor chatters during startup or during operation.	<ol style="list-style-type: none"> Phase converter (if used) wild wire connected to wrong terminal(G0514X3). Power supply has incorrect voltage on one or more legs. 	<ol style="list-style-type: none"> Connect wild wire to the machine power supply terminal that is not part of the switch coil circuit (G0514X3). Contact electrician to check incoming voltage.
Machine operates in reverse.	<ol style="list-style-type: none"> Power connections wired out of phase (G0514X3). 	<ol style="list-style-type: none"> Swap two power incoming power leads at the motor (G0514X3).



Symptom	Possible Cause	Possible Solution
Machine has excessive vibration or noise.	<ol style="list-style-type: none"> 1. V-belt tension incorrect. 2. Bent, dull, or damaged blade. 3. Loose or damaged blade. 4. Blade weld contacting support bearing or blade guides. 5. Loose machine component. 6. Machine incorrectly mounted on floor. 7. Phase converter (if used) wild wire connected to wrong terminal(G0514X3). 8. Motor fan rubbing on fan cover. 9. V-belt worn or damaged. 10. Wheels not coplanar. 11. V-belt has a high spot. 12. Centrifugal switch out of adjustment; at fault. 13. Pulley loose or not in alignment; shaft bent. 14. Worn wheel bearing. 15. Wheel tires worn or incorrectly installed. 16. Wheels out of balance. 17. Motor bearings worn or damaged. 	<ol style="list-style-type: none"> 1. Tighten V-belt. See Page 59. 2. Replace blade (Page 49). 3. Tighten or replace blade. 4. Use file or stone to smooth and round the back of the blade. 5. Tighten loose component. 6. Level/shim base; tighten/adjust mounting hardware or feet. 7. Connect wild wire to the machine power supply terminal that is not part of the switch coil circuit (G0514X3) 8. Fix/replace fan cover; replace loose or damaged fan. 9. Replace V-belt. (Use link belts if possible.) See Page 60. 10. Adjust wheels coplanar (Page 65). 11. Replace/adjust the V-belt (Page 60). 12. Adjust/replace centrifugal switch. 13. Replace worn pulley, key, and shaft, and realign. 14. Check/replace wheel bearing. 15. Replace or re-install tires. 16. Replace wheels. 17. Replace motor bearings or replace motor.
Machine stalls or slows when operating.	<ol style="list-style-type: none"> 1. Too much pressure when feeding workpiece. 2. Workpiece too moist or material not suitable for machine. 3. Workpiece is warped. 4. Fence incorrectly adjusted. 5. Belt(s) slipping. 6. Run capacitor at fault. 7. Motor connection wired incorrectly. 8. Motor is wired out of phase (G0514X3). 9. Motor overheated. 10. Contactor has poor contacts or is at fault. 11. Centrifugal switch at fault. 12. Motor at fault. 	<ol style="list-style-type: none"> 1. Reduce pressure when feeding workpiece. 2. Only cut wood and ensure moisture is below 20%. 3. Straighten workpiece or use a different one. 4. Adjust/calibrate fence. 5. Tension/replace belt(s); ensure pulleys are aligned. 6. Test/repair/replace. 7. Review wiring diagram on motor cover; correct wire connections. 8. Swap any two incoming power leads. 9. Let cool, clean motor, and reduce workload. 10. Test all legs for power, test field coil, and fix contacts or replace if at fault. 11. Adjust/replace centrifugal switch if available. 12. Test for shorted windings, bad bearings and repair or replace.
Miter bar binds in miter slot.	<ol style="list-style-type: none"> 1. Miter slot dirty or gummed up. 	<ol style="list-style-type: none"> 1. Carefully clean miter slot.
Table does not tilt to 90 degrees.	<ol style="list-style-type: none"> 1. Pointer or scale calibrated incorrectly. 2. Positive stop bolt not set correctly. 	<ol style="list-style-type: none"> 1. Calibrate pointer/scale at true 90 degrees (Page 25). 2. Adjust positive stop bolt.
Table does not tilt to 45 degrees.	<ol style="list-style-type: none"> 1. Pointer or scale calibrated incorrectly. 2. Machine component blocking path. 	<ol style="list-style-type: none"> 1. Calibrate pointer/scale at true 45 degrees. 2. Remove component blocking table.



Symptom	Possible Cause	Possible Solution
Table hard to tilt.	<ol style="list-style-type: none"> 1. Sawdust or pitch trapped between trunnion and base. 2. Metal burrs on trunnion. 	<ol style="list-style-type: none"> 1. Calibrate pointer/scale at true 45 degrees. 2. Remove burrs.
The cuts are rough, or show scoring.	<ol style="list-style-type: none"> 1. Blade is overloaded and twists. 2. The blade TPI is too coarse. 3. The blade is loose and slipping on wheels. 4. Blade tracking is incorrect. 5. The blade has missing or bent teeth. 6. The blade has a faulty weld. 	<ol style="list-style-type: none"> 1. Decrease the feed rate. 2. Use the correct blade for material and speed of cut. 3. Adjust bade tension as required. 4. Adjust the blade tracking back to normal. 5. Replace the blade (Page 49). 6. Replace the blade (Page 49).
Blade or teeth break.	<ol style="list-style-type: none"> 1. Blade tension is incorrect. 2. Incorrect blade for application. 3. The feed is too heavy or blade speed is wrong. 4. Cutting corners too sharply. 5. Blade used when dull. 6. Blade tracking is wrong. 7. Blade guide adjustment at fault. 8. Inadequate blade support. 9. Blade weld at fault. 10. Wheel tires worn or incorrectly installed. 11. Fence or miter slot out of alignment with blade. 	<ol style="list-style-type: none"> 1. Adjust blade tension (Page 31). 2. Use correct blade for application. 3. Reduce feed rate or increase blade speed (Page 39). 4. Use a wider arc on outside cuts, or use relief cuts to make tight inside cuts. 5. Replace the blade (Page 49). 6. Adjust the blade tracking back to normal (Page 23). 7. Adjust blade guide bearings for correct blade support. 8. Adjust upper blade guide so it is as close as possible to workpiece. 9. Replace with blade from different manufacturer (Page 49). 10. Replace or re-install tires. 11. Align table miter slot and fence with blade (Page 35).
Blade wears on one side, slows, smokes or shows overheating.	<ol style="list-style-type: none"> 1. Blade contacting table insert. 2. The blade guides are worn or mis-adjusted. 3. The blade has insufficient support. 4. Blade is installed backwards. 5. Blade spinning backwards due to out of phase wiring (3-phase only, G0514X3). 6. Too much side pressure when feeding workpiece. 7. The wheels are out of alignment. 8. Dull or incorrect blade. 9. Blade is bell-mouthed. 10. Fence not parallel with blade (pressure at blade backside). 11. Table top surface is not parallel or square to blade. 	<ol style="list-style-type: none"> 1. Adjust blade guide bearings to eliminate excess side pressure. Adjust table for correct blade clearance and miter slot alignment. 2. Tighten the blade guide bracket. 3. Tighten the blade guide as close to the workpiece as possible. 4. Check blade rotation as described in Test Run” and reverse blade if necessary. 5. Switch two of the current carrying wires at the terminal strip. 6. Feed workpiece straight into the blade. 7. Adjust the wheels so they are coplanar (Page 65). 8. Replace blade (Page 49). 9. Install new blade. 10. Adjust fence parallel with blade (Page 35). 11. Adjust/shim table/trunnion position until blade and table are parallel and square.
Sawdust buildup inside cabinet.	<ol style="list-style-type: none"> 1. Clogged dust port. 2. Low CFM (airflow) from dust collection system. 	<ol style="list-style-type: none"> 1. Clean out dust port. 2. Repair ducting for leaks or clogs, move dust collector closer to machine, install a stronger dust collector.



Symptom	Possible Cause	Possible Solution
Blade tracks incorrectly, or comes off wheels.	<ol style="list-style-type: none"> 1. Tracking is not adjusted properly. 2. Wheels are not coplanar. 3. Blade tension is too loose. 4. Blade guides need adjustment. 5. Feeding workpiece too fast. 6. Incorrect blade for bandsaw. 7. Blade is bell-mouthed, worn or dull. 8. Rubber tire on wheel is damaged or worn. 	<ol style="list-style-type: none"> 1. Adjust tracking (Page 23). 2. Adjust wheel coplanarity (Page 65). 3. Increase blade tension (Page 31). 4. Adjust blade guides (Page 33). 5. Feed workpiece slower (Page 39). 6. Install correct blade for machine. 7. Install new blade, and de-tension blade when not in use. 8. Replace rubber tires.
The cut is crooked, or the blade wanders (blade lead).	<ol style="list-style-type: none"> 1. The feed pressure is too high or the blade speed is wrong. 2. The blade tension is low. 3. The blade is dull or damaged. 4. Inadequate blade support. 5. Incorrect blade for application. 6. The blade tracking is wrong. 7. Table is loose. 8. Fence or miter slot out of alignment with blade. 9. Blade guide alignment at fault. 	<ol style="list-style-type: none"> 1. Adjust feed rate and cutting speed as required. 2. Increase the blade tension (Page 31). 3. Replace the blade (Page 49). 4. Adjust upper blade guide so it is as close as possible to workpiece (Page 33). 5. Use wider blade. 6. Adjust the blade tracking back to normal. 7. Tighten table trunnion mounting bolts or tilt lock lever. 8. Align table miter slot and fence with blade. 9. Adjust blade guide bearings for correct blade support.



Checking V-Belt

To ensure optimum power transmission from the motor to the blade, the V-belt must be in good condition and operate under proper tension. The belt should be checked for cracks, fraying, and wear. Belt tension should be checked at least every 3 months—more often if the bandsaw is used daily.

To check the V-belt:

1. DISCONNECT BANDSAW FROM POWER!
2. Open the lower wheel cover.
3. Note the condition of the V-belt. If the V-belt is cracked, frayed, or glazed, replace it.
4. Push the center of the V-belt. Note the amount of deflection (**Figure 96**). If deflection is more than $\frac{3}{4}$ ", re-tension the V-belt.

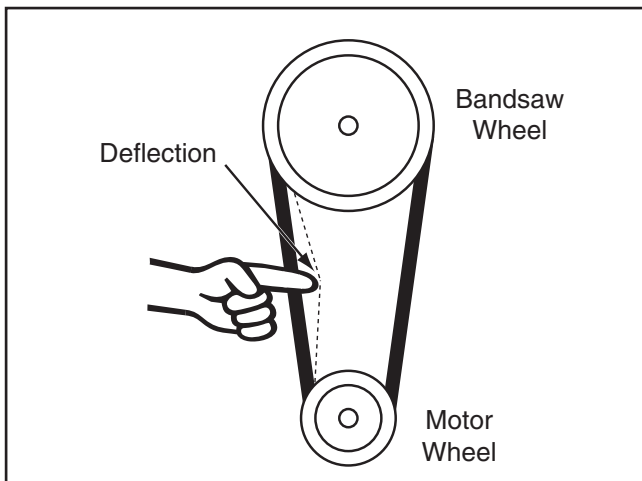

Figure 96. V-belt deflection.

Tensioning V-Belt

Tools Needed: Qty
Hex Wrench 6mm..... 1

To tension the V-belt:

1. DISCONNECT BANDSAW FROM POWER!
2. Open the lower wheel cover.
3. Loosen the motor mount screws shown in **Figure 97**.

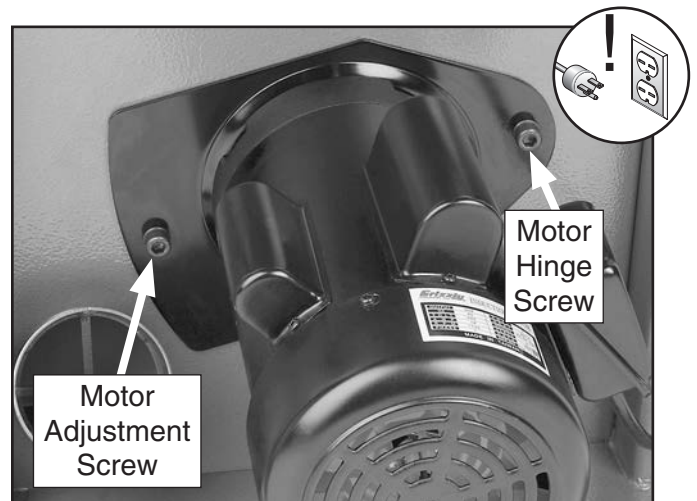

Figure 97. Motor mount screws.

4. Rotate the motor down to tension the V-belt, then tighten the motor adjustment screw.
5. Push the center of the V-belt. If deflection is approximately $\frac{3}{4}$ " with moderate pressure from your thumb or finger, then the tension is correct. If the deflection is more than $\frac{3}{4}$ ", repeat **Steps 3 & 4**.
6. When the V-belt tension is correct, tighten the motor hinge screw and close the lower wheel cover.



Replacing V-Belt

Tools Needed:	Qty
Hex Wrench 6mm.....	1
Hex Wrench 8mm.....	1

To replace the V-belt:

1. DISCONNECT BANDSAW FROM POWER!
2. Open both wheel covers, and remove the blade.
3. Loosen the motor mount screws shown in **Figure 97**.
4. Rotate the motor up to loosen the V-belt, then tighten the motor adjustment screw.
5. Pull the V-belt off of the motor pulley.
6. Unthread the wheel mount bolt shown in **Figure 98** and slide the lower wheel off of the bearing shaft.

7. Slip the old V-belt off of the wheel pulley and install the new V-belt in its place.
8. Install the lower wheel back onto the bearing shaft and replace/tighten the wheel mount bolt.
9. Slip the new V-belt onto the motor pulley.
10. Rotate the motor down to tension the V-belt, then tighten the motor adjustment screw.
11. Check the V-belt tension and adjust if necessary as described in the **Tensioning V-Belt** instructions on **Page 59**.
12. When the V-belt tension is correct, tighten the motor hinge bolt and close the lower wheel cover.

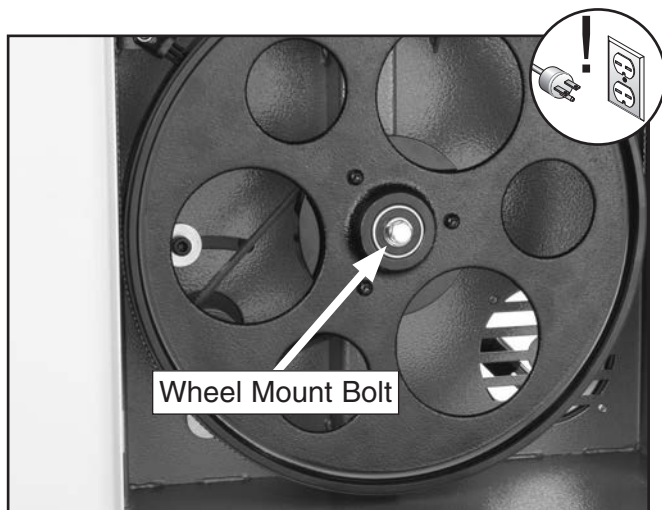

Figure 98. Example of wheel mount bolt.



Blade Lead

Bandsaw blades commonly wander off the cut line when sawing, as shown in **Figure 99**. This is called blade lead. Blade lead is commonly caused by too fast of a feed rate, a dull or abused blade, or improper tension. If your blade is sharp/undamaged and you still have blade lead, perform the following instructions.

Tools Needed: Qty
Scrap Wood Cut to $\frac{3}{4}$ " x 3" x 17" 1



Figure 99. Blade leading away from line of cut.

To correct blade lead:

1. Use less pressure when feeding the workpiece through the cut.
2. Check that the miter slot or fence is parallel to the blade line, and correct if necessary.
3. Check for proper blade tension. If the blade tension is correct and it is not convenient to replace the blade, compensate for lead by skewing the fence or adjusting the table.

To skew your fence:

1. Cut a piece of scrap wood approximately $\frac{3}{4}$ " thick x 3" wide x 17" long. On a wide face of the board, draw a straight line parallel to the long edge.

2. Cut halfway through the board on the line by pushing it into the blade. Turn the bandsaw **OFF** and wait for the blade to stop.
3. Clamp the board to the bandsaw table without moving it. Now slide the fence over to the board so it barely touches one end of the board.
4. Loosen the four cap screws on top of the fence.
5. Skew the fence so it is parallel to the edge of the scrap piece. You may need to re-adjust the fence locking mechanisms to gain maximum adjustment.
6. While maintaining the skew, tighten the cap screws.

To shift the table:

1. On a scrap piece of wood, mark a line that is perpendicular to the front edge.
2. Cut halfway through the board on the line by pushing it into the blade.
3. Turn the bandsaw **OFF** and wait for the blade to stop.
4. Loosen the table mounting bolts. Shift the table to compensate for the blade lead, then retighten the table bolts.
5. Repeat **Steps 1–4** until the blade cuts straight.



Adjusting Wheel Brush

The lower wheel compartment contains two wheel brushes, one of which is shown in **Figure 100**. These brushes are designed to sweep sawdust off the wheel tire as the bandsaw is operating. In order to work properly each brush must make contact with the wheel.

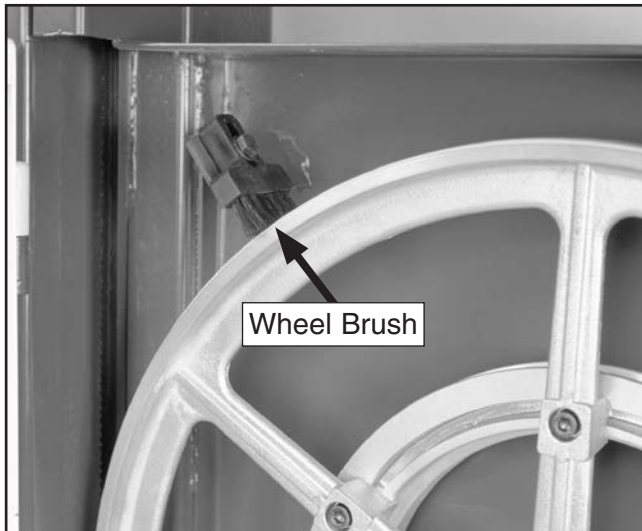

Figure 100. A wheel brush (one of two shown).

Tools Needed:	Qty
Wrench/Socket 10mm	2

To adjust the brushes:

1. DISCONNECT BANDSAW FROM POWER!
2. Open the lower wheel cover.
3. Loosen the bolt/nut that secures each brush in place.
4. Adjust each brush so it makes good contact with the wheel or blade—without bending the bristles.
5. Tighten the bolt/nuts to secure each brush in place.

Adjusting Tension Lever

The quick release tension lever is setup correctly for use with the preinstalled 143" blade. However, if you install a different length blade, you will need to adjust the tension lever adjustment screw so the quick release tension lever works correctly.

Tools Needed:	Qty
Hex Wrench 5mm.....	1
Wrench 10mm	1

To adjust the tension lever:

1. DISCONNECT BANDSAW FROM POWER!
2. Open the wheel covers, remove the bandsaw blade, then install the new one (refer to **Blade Changes** on **Page 49**).
3. Loosen the jam nut on the tension adjustment screw 7-10 turns.
4. Put the quick release tension lever in the down (engaged) position, then turn the blade tension handwheel until the blade tension matches the mark on the blade tension scale for the appropriate blade thickness.
5. Thread the tension adjustment screw (**Figure 101**) down until it contacts the wheel block plate, then back it off 1-2 turns.

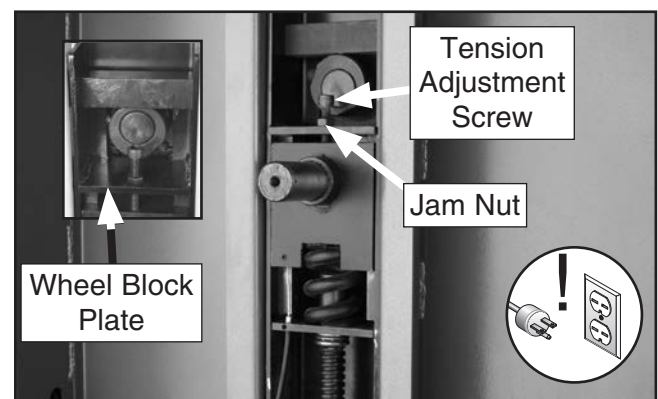

Figure 101. Example of quick release tension lever adjustment screw.

6. Tighten the jam nut.



Adjusting Guide Post Travel

The guide post assembly should remain parallel with the blade front-to-back and side-to-side along its length of travel. If it does not, follow these instructions to correctly adjust the guide post.

Tools Needed:

Machinist's Square	1
Small Ruler	1
Hex Wrench 4mm.....	1
Hex Wrench 5mm.....	1
Metal Shims.....	(As Needed)

Checking/Adjusting Guide Post Parallel with Blade Side-to-Side

1. DISCONNECT BANDSAW FROM POWER!
2. Tighten the blade to the tension that will be used during operation.
3. Loosen the guide post lock knob, raise the guide post and lock it in place, then place a machinist's square on the table next to the side of the blade as illustrated in **Figure 102**.

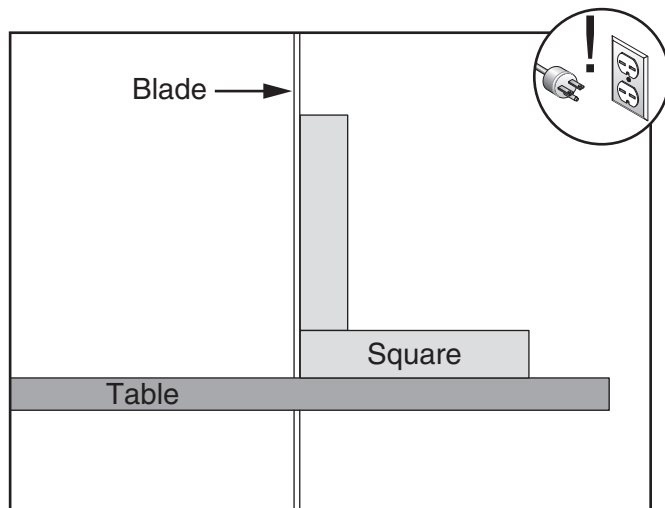

Figure 102. Squaring table to blade.

4. Adjust the table square with the blade using the table tilt knob, then secure it with the table tilt lock lever.

5. Loosen the guide post lock knob, lower the guide post to within 1" of the table top, then tighten the knob.
6. Place a machinist's square on the table next to the right hand side of the guide post, as shown in **Figure 103**.

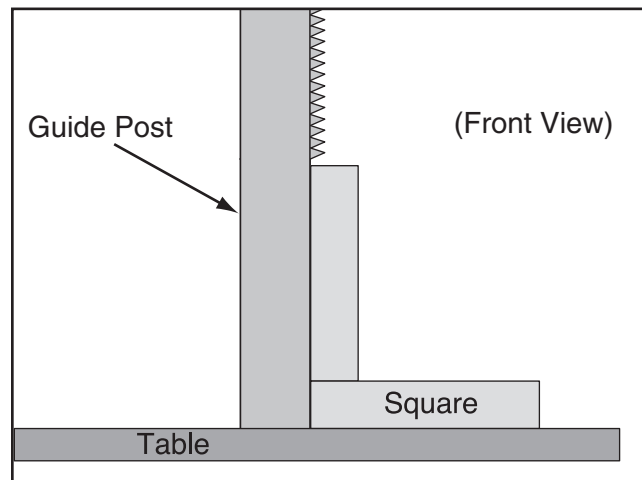

Figure 103. Example of checking guide post squareness.

—If there is no gap between the square and the guide post along its full length, no adjustments need to be made. Proceed to "To check/adjust if the guide post is parallel with the blade front-to-back."

—If there is a gap between the square and the guide post, the guide post is not parallel to the blade. Go to **Step 7**.

7. Loosen each of the four screws shown in **Figure 104** ¼ turn.

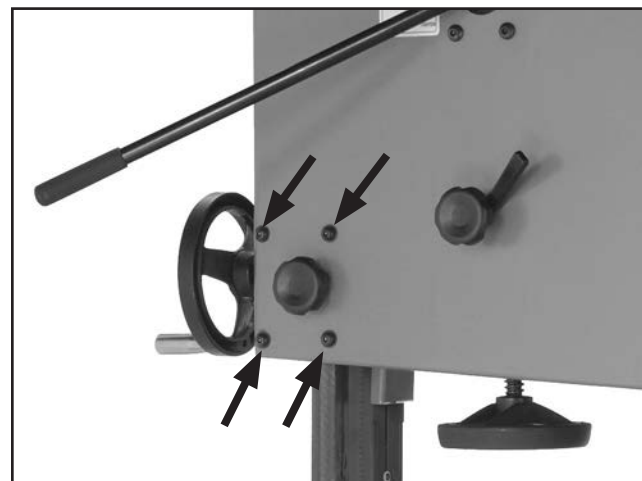

Figure 104. Guide post adjustment screws.



8. Gently tap the lower part of the guide post in the appropriate direction until there is no gap between the square and the guide post.
9. Tighten the screws shown in **Figure 104**.

Checking/Adjusting Guide Post Parallel with Blade Front-to-Back

1. DISCONNECT BANDSAW FROM POWER!
2. Loosen the guide post lock knob, lower the blade guide assembly to within 1" of the table top, then tighten the lock knob.
3. Remove the screws that secure the guide post guard and move it up and out of the way.
4. Measure the distance "A" between the top front face of the guide post rack and the back of the blade (see **Figure 105**).

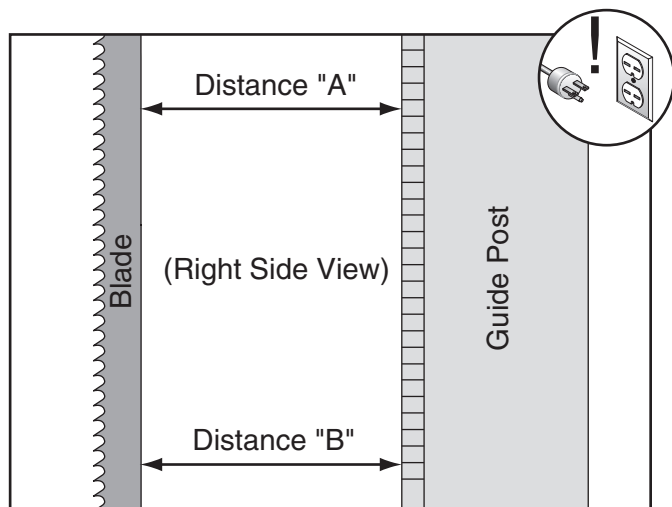

Figure 105. Example of measuring distance between rack and blade at top of guide post.

5. Measure the distance "B" between the bottom front face of the guide post rack and the back of the blade (see **Figure 105**).

—If the measurements taken in **Steps 4–5** are equal, no adjustments need to be made. Go to **Step 9**.

—If the measurements taken in **Steps 4–5** are not equal, go to **Step 6**.

6. Place the guide post guard on top of the guide post assembly so you can access the guide post bracket.
7. Loosen the four screws shown in **Figure 104** enough to fit metal shims between the frame and the guide post bracket (see **Figure 106**).

—If the guide post to blade distance is greater at the bottom than at the top, place a shim between the bottom of the bracket and the frame (Shim "A"). This will tilt the bottom of the guide post toward the blade.

—If the guide post to blade distance is less at the bottom than at the top, place a shim between the top of the bracket and the frame (Shim "B"). This will tilt the bottom of the guide post away from the blade.

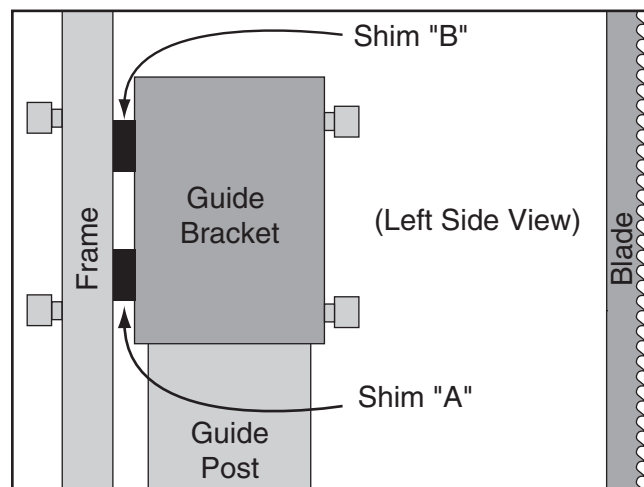

Figure 106. Location for placing shims.

8. Tighten the four screws shown in **Figure 104**, then repeat **Steps 4–5**.

—If the measurements are equal, go to **Step 9**.

—If the measurements are not equal, continue adding shims as needed until guide post rack to blade distance is the same at the top and bottom.

9. Reinstall the guide post guard with the screws removed in **Step 3**.



Aligning Wheels

Components and Hardware Needed: Qty
 60" Long 2x4 1

Tools Needed:

Hex Wrenches 4 & 6 mm 1 Ea
 Wrench 13mm 1
 Tape Measure 1
 Coplanarity Gauge (see **Figure 107**) 1
 Straightedge 1
 Fine Ruler 1

Wheel alignment is one of the most critical factors for optimal performance from your bandsaw.

Heat, vibration, wandering, blade wear, tire wear and overall bandsaw wear are considerably decreased when the wheels are properly aligned or "coplanar."

Coplanar wheels automatically track the blade by balancing it on the crown of the wheel. This is known as coplanar tracking.

Checking Coplanarity

1. Make the "Coplanarity Gauge" shown in **Figure 107**.

Note: For best results, straighten the 2x4 with a jointer before cutting.

2. DISCONNECT BANDSAW FROM POWER!
3. Remove the fence and open both wheel covers.
4. Adjust the blade guides away from the blade, loosen blade tension, remove the table insert and pin, then remove the blade.
5. Remove the table.
6. Reinstall the blade (**Page 49**), making sure the guide bearings and support bearings are away from the blade, then tighten your blade to the tension that it will be used during operation.
7. Place your coplanarity gauge up against both wheels in the positions shown in **Figure 108**.

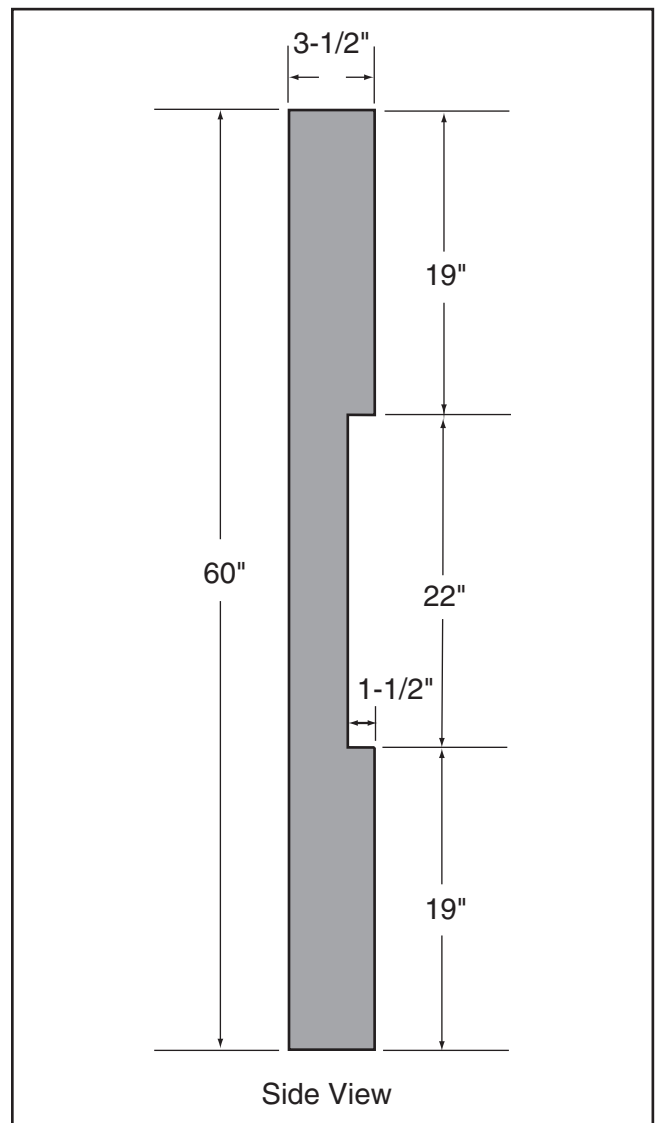

Figure 107. Dimensions of coplanarity gauge.

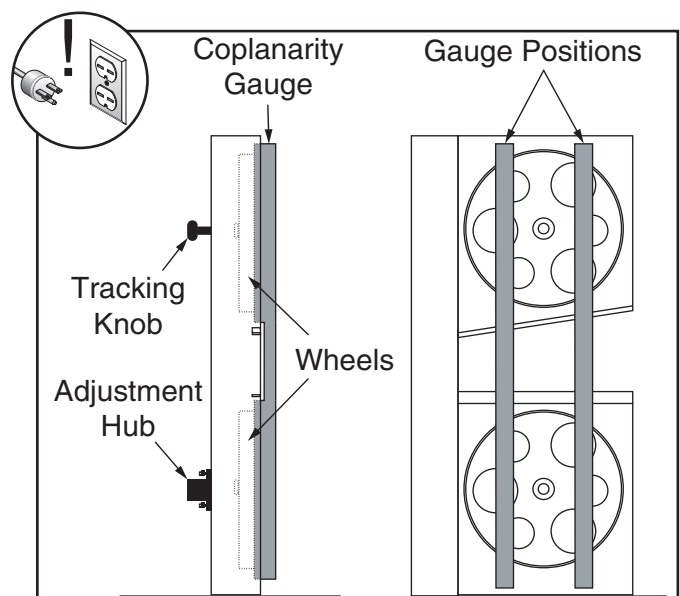

Figure 108. Checking for coplanarity.



—If the wheels are coplanar (**Figure 109, A**), the straightedge will evenly touch the top and bottom of both wheels.

—If the wheels are not coplanar (**Figure 109, B**), place the straightedge on the lower wheel first (ensuring that it touches both the top and bottom rim), then adjust the upper wheel tracking knob to make the upper wheel coplanar and parallel with the lower wheel.

—If the straightedge does not touch both wheels evenly, the lower wheel needs to be adjusted (**Figure 109, C**) or the upper wheel needs to be shimmed (**Figure 109, D**).

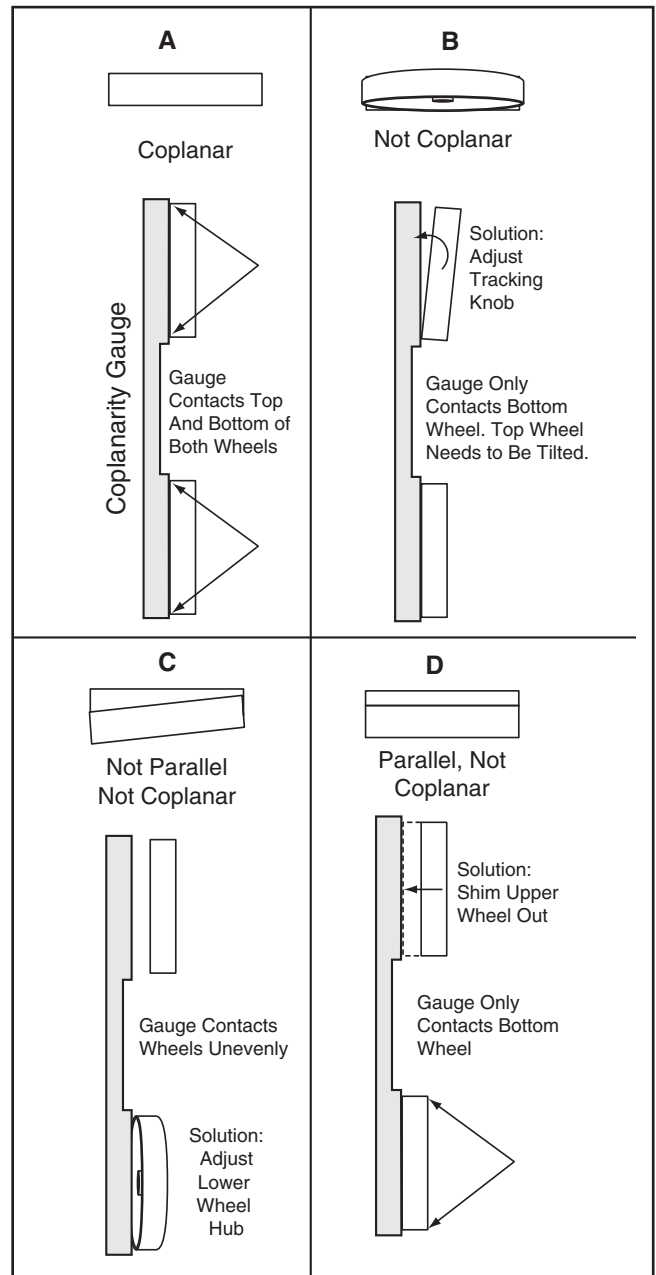

Figure 109. Coplanar diagram.

Shimming Upper Wheel

1. DISCONNECT BANDSAW FROM POWER!
2. Make sure the top wheel is adjusted parallel with the bottom wheel.
3. With a straightedge touching both points of the wheel that does not need to be adjusted, measure the distance away from the wheel that is out of adjustment (see **Figure 110**).
4. Remove the blade from the saw, then remove the wheel that needs to be shimmed.
5. Determine how many shim washers you need to compensate for the distance measured in **Step 3** and place them on the wheel shaft.
6. Replace the wheel, the original washers, the securing screw, and the blade.
7. Tighten the blade, then check the wheels with the coplanarity gauge. (Wheel coplanarity changes as the blade is tightened, so it is best to check the wheel alignment when the blade is tensioned as it would be for normal operations.)
8. When the wheels are coplanar, place a mark on each wheel where you held the straightedge. This assures repeated accuracy every time you adjust your wheels.

Note: When wheels are properly coplanar, the blade may not be centered on the crown of the wheel, but it will be balanced.

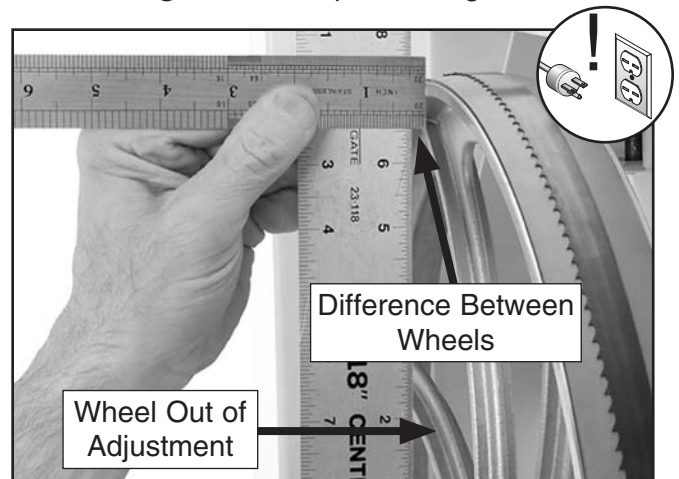

Figure 110. Determining distance needed to shim upper wheel.



Adjusting Lower Wheel

Only do this procedure if you cannot make the wheels coplanar with the tracking knob or by shimming the upper wheel. Make sure the upper wheel is adjusted as close as possible to being coplanar with the lower wheel before beginning. Do this procedure with the blade fully tensioned.

To adjust the lower wheel:

1. DISCONNECT BANDSAW FROM POWER!
2. Loosen the jam nuts on the lower wheel adjustment hub (see **Figure 111**).

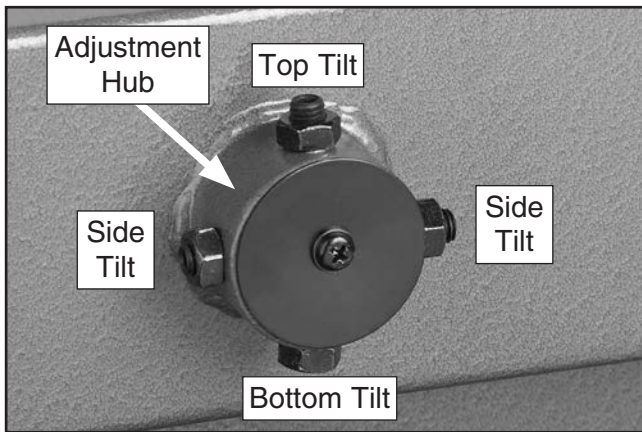

Figure 111. Lower wheel adjustment control.

3. Loosen one tilt adjustment set screw, then tighten the opposing set screw approximately an equal amount.
4. Check the wheels with the coplanarity gauge, then adjust the lower wheel at the hub as needed until it is parallel and coplanar with the top wheel.
5. Tighten the jam nuts to lock the tilt adjustment set screws in position.



SECTION 8: WIRING

These pages are current at the time of printing. However, in the spirit of improvement, we may make changes to the electrical systems of future machines. Compare the manufacture date of your machine to the one stated in this manual, and study this section carefully.

If there are differences between your machine and what is shown in this section, call Technical Support at (570) 546-9663 for assistance BEFORE making any changes to the wiring on your machine. An updated wiring diagram may be available. **Note:** *Please gather the serial number and manufacture date of your machine before calling. This information can be found on the main machine label.*

WARNING

Wiring Safety Instructions

SHOCK HAZARD. Working on wiring that is connected to a power source is extremely dangerous. Touching electrified parts will result in personal injury including but not limited to severe burns, electrocution, or death. Disconnect the power from the machine before servicing electrical components!

MODIFICATIONS. Modifying the wiring beyond what is shown in the diagram may lead to unpredictable results, including serious injury or fire. This includes the installation of unapproved after-market parts.

WIRE CONNECTIONS. All connections must be tight to prevent wires from loosening during machine operation. Double-check all wires disconnected or connected during any wiring task to ensure tight connections.

CIRCUIT REQUIREMENTS. You MUST follow the requirements at the beginning of this manual when connecting your machine to a power source.

WIRE/COMPONENT DAMAGE. Damaged wires or components increase the risk of serious personal injury, fire, or machine damage. If you notice that any wires or components are damaged while performing a wiring task, replace those wires or components.

MOTOR WIRING. The motor wiring shown in these diagrams is current at the time of printing but may not match your machine. If you find this to be the case, use the wiring diagram inside the motor junction box.















CAPACITORS/INVERTERS. Some capacitors and power inverters store an electrical charge for up to 10 minutes after being disconnected from the power source. To reduce the risk of being shocked, wait at least this long before working on capacitors.

EXPERIENCING DIFFICULTIES. If you are experiencing difficulties understanding the information included in this section, contact our Technical Support at (570) 546-9663.

NOTICE

The photos and diagrams included in this section are best viewed in color. You can view these pages in color at www.grizzly.com.

COLOR KEY

BLACK 	BLUE 	YELLOW 	LIGHT BLUE 
WHITE 	BROWN 	YELLOW GREEN 	BLUE WHITE 
GREEN 	GRAY 	PURPLE 	TURQUOISE 
RED 	ORANGE 	PINK 	



G0514X Wiring Diagram

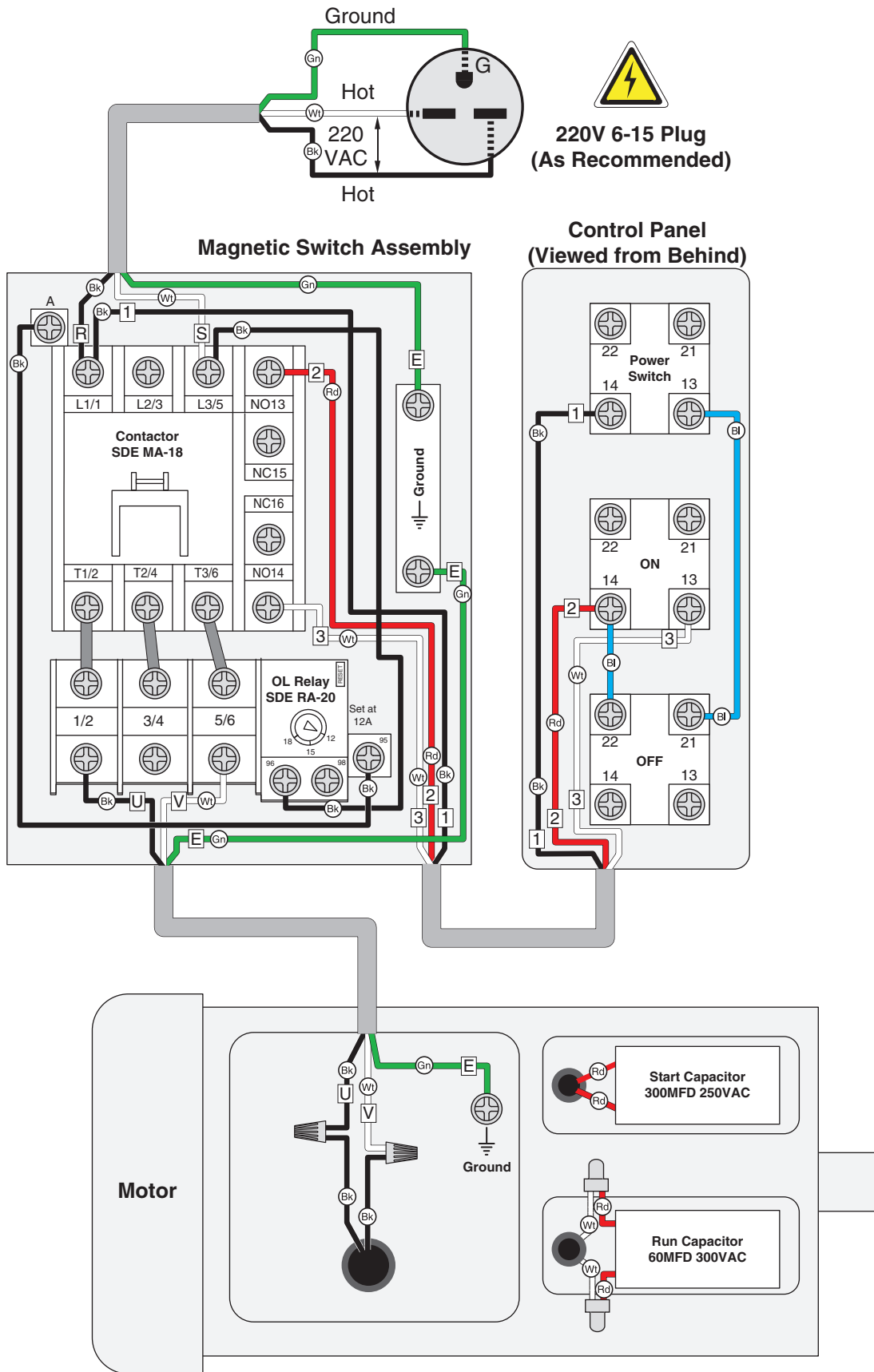

G0514X2 Wiring Diagram

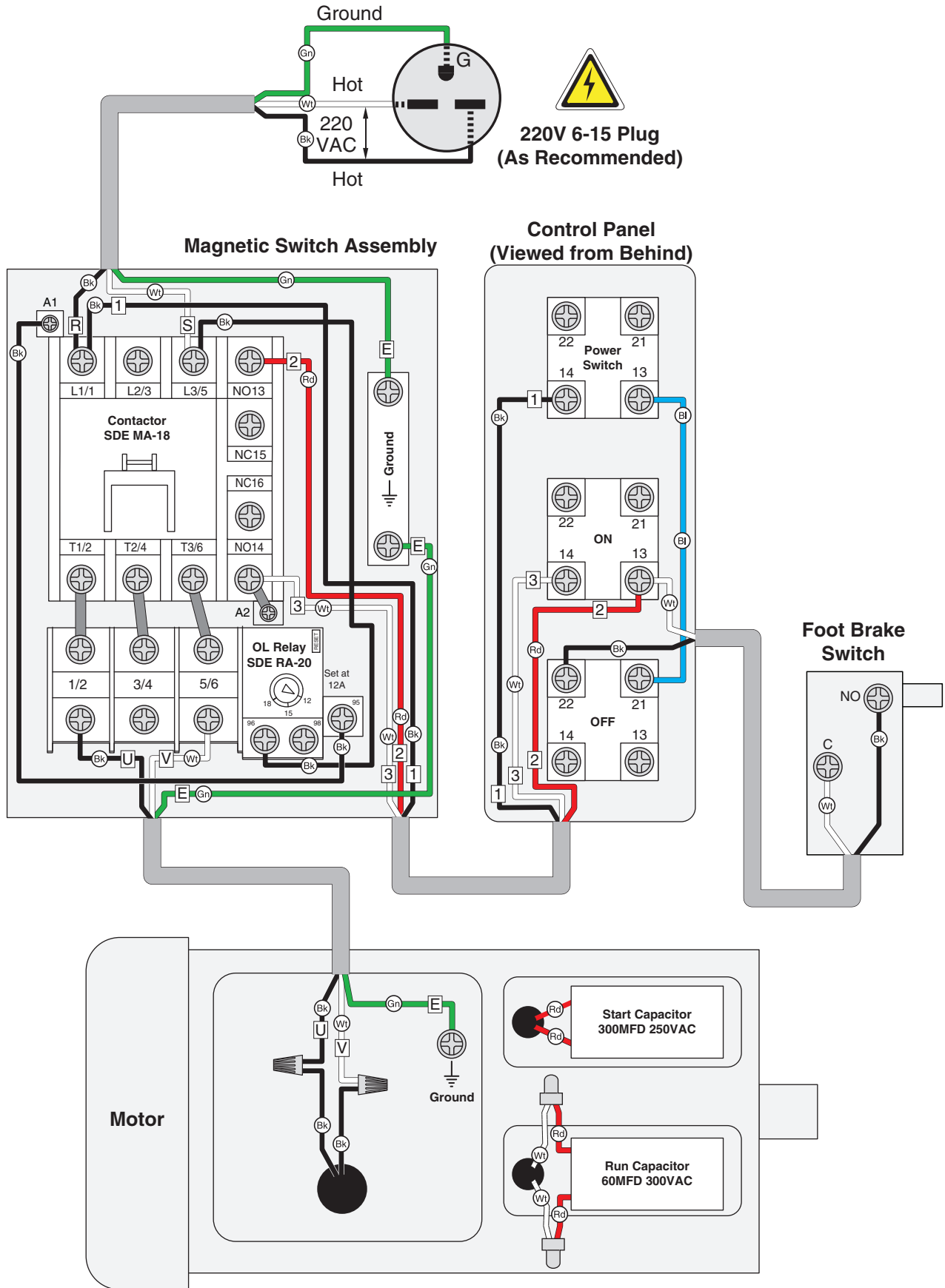

G0514X2B Wiring Diagram

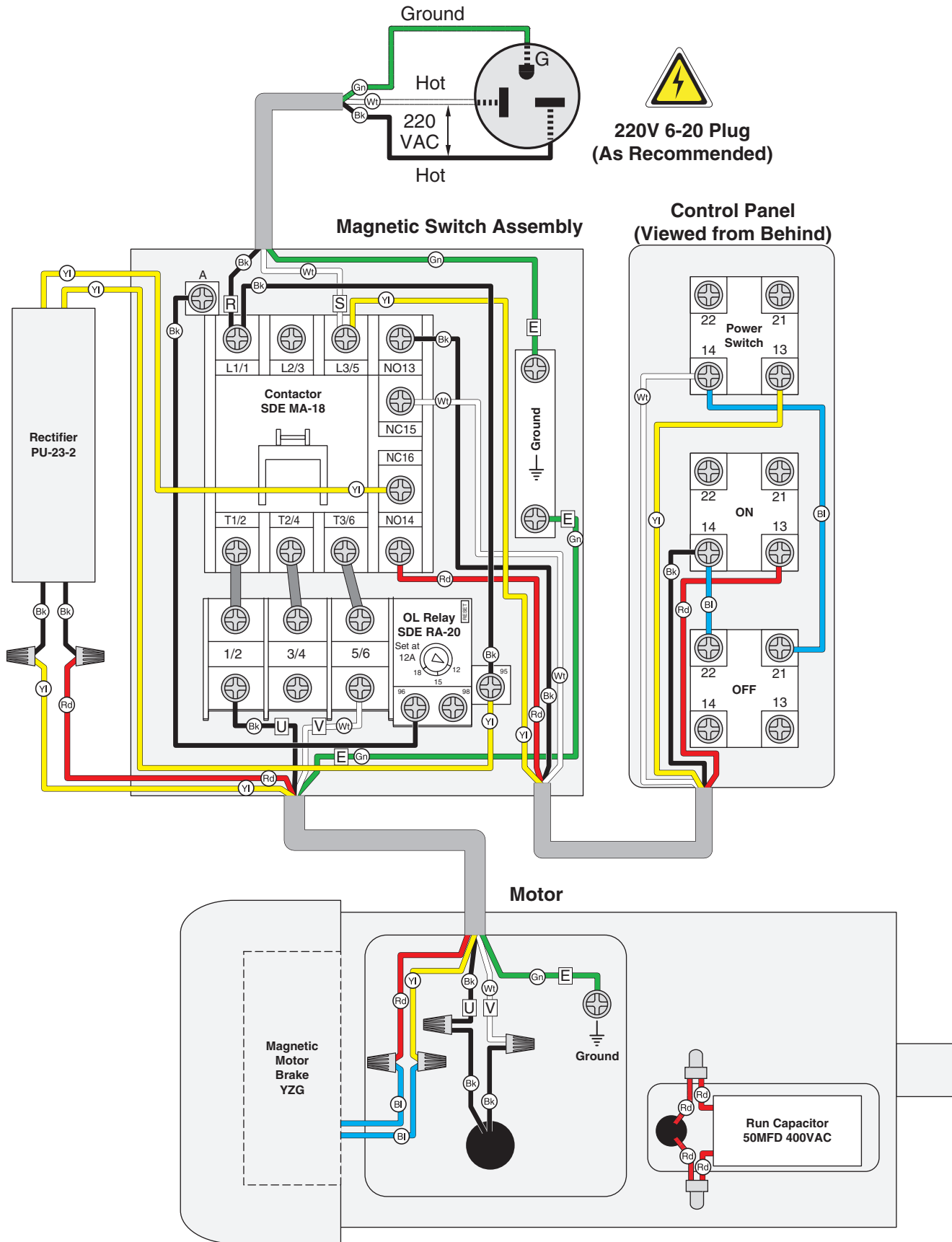

G0514X3 Wiring Diagram

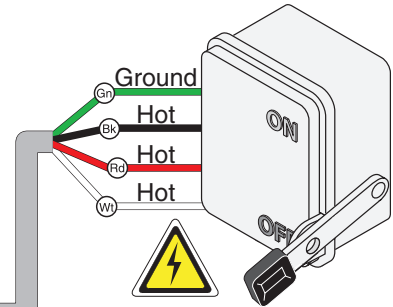
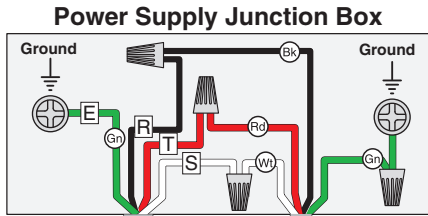

Magnetic Switch Assembly

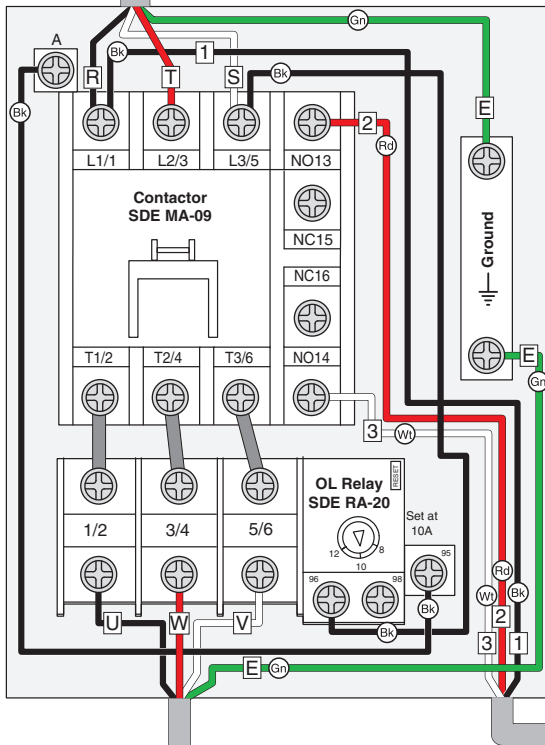

Control Panel (Viewed from Behind)

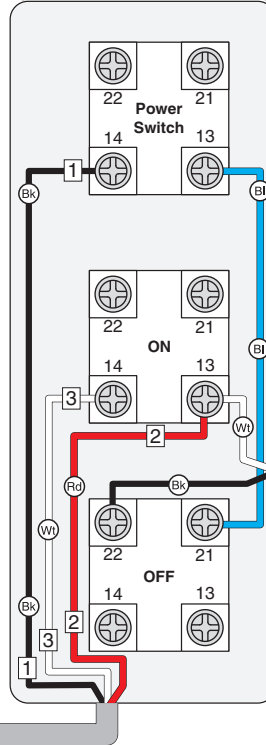

Locking Disconnect Switch (As Recommended)

Foot Brake Switch

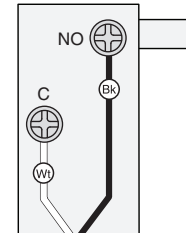

(Must also replace magnetic switch with 440V version)

220V Motor

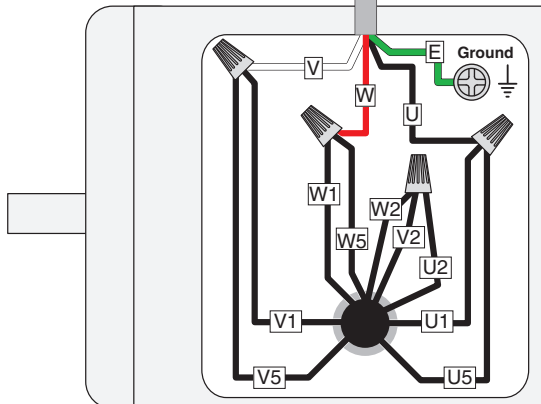

440V Motor

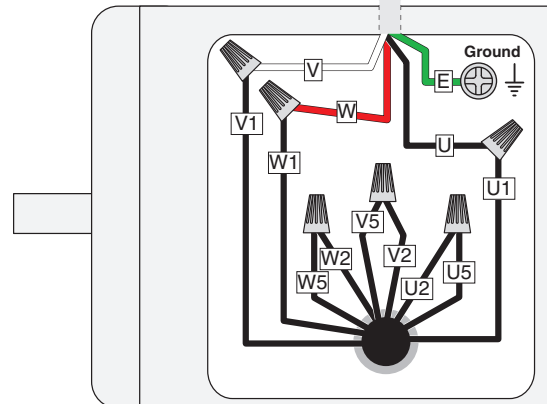

SECTION 9: PARTS

G0514X Main

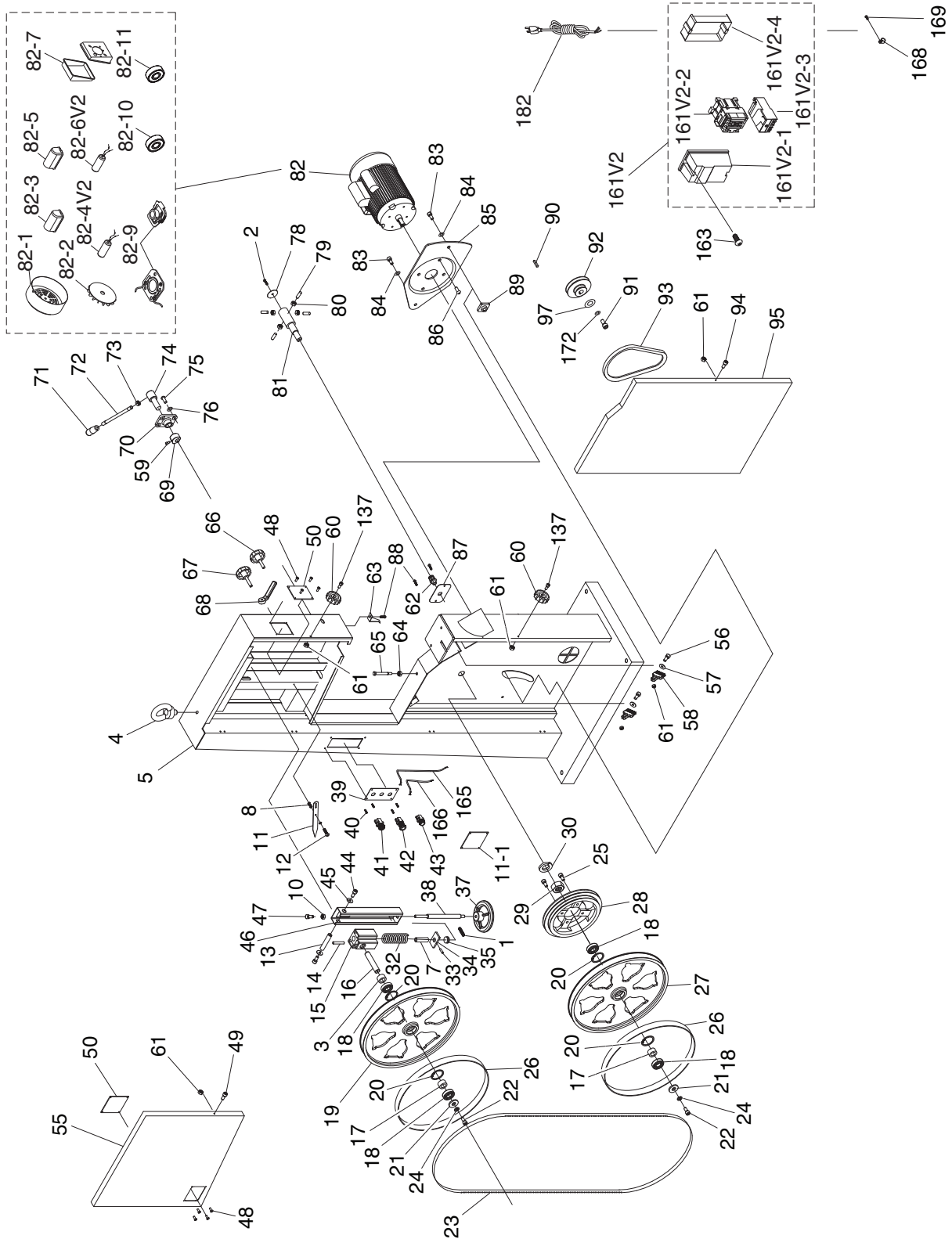

G0514X Main Parts List

REF	PART #	DESCRIPTION
1	P0514X001	SET SCREW M6-1 X 10
2	P0514X002	FLANGE SCREW M5-.8 X 10
3	P0514X003	BUSHING
4	P0514X004	LIFTING EYE BOLT M10-1.5
5	P0514X005	MACHINE BODY
7	P0514X007	BUSHING
8	P0514X008	FLAT WASHER 6MM
10	P0514X010	HEX NUT M6-1
11	P0514X011	POINTER
11-1	P0514X011-1	TENSION SCALE LABEL
12	P0514X012	SHOULDER SCREW M4-.7 X 5
13	P0514X013	UPPER SHAFT
14	P0514X014	ROLL PIN 5 X 36
15	P0514X015	UPPER WHEEL SHAFT HINGE
16	P0514X016	UPPER WHEEL SHAFT
17	P0514X017	BUSHING
18	P0514X018	BALL BEARING 6204 2RS
19	P0514X019	UPPER WHEEL 19"
20	P0514X020	INT RETAINING RING 47MM
21	P0514X021	WHEEL FLAT WASHER 8MM
22	P0514X022	CAP SCREW M8-1.25 X 16
23	P0514X023	BLADE 6TPI HOOK 143"
24	P0514X024	LOCK WASHER 8MM
25	P0514X025	CAP SCREW M8-1.25 X 20
26	P0514X026	URETHANE TIRE PAIR
27	P0514X027	LOWER WHEEL 19"
28	P0514X028	IDLER PULLEY
29	P0514X029	HEX NUT 1-14
30	P0514X030	LOCK WASHER 1"
32	P0514X032	COMPRESSION SPRING
33	P0514X033	ROLL PIN 3 X 16
34	P0514X034	LOCATE BLOCK
35	P0514X035	THRUST BEARING 51201
37	P0514X037	HANDWHEEL
38	P0514X038	ADJUSTING BOLT
39	P0514X039	CONTROL PANEL PLATE
40	P0514X040	TAP SCREW M4 X 10
41	P0514X041	KEYED POWER SWITCH
42	P0514X042	ON BUTTON
43	P0514X043	OFF BUTTON
44	P0514X044	CAP SCREW M8-1.25 X 16
45	P0514X045	FENDER WASHER 8MM
46	P0514X046	UPPER WHEEL SLIDING BRACKET
47	P0514X047	CAP SCREW M8-1.25 X 90
48	P0514X048	STEEL BLIND RIVET 3 X 10MM
49	P0514X049	CAP SCREW M6-1 X 10
50	P0514X050	CLEAR WINDOW
55	P0514X055	UPPER WHEEL COVER
56	P0514X056	CAP SCREW M6-1 X 25
57	P0514X057	FLAT WASHER 6MM
58	P0514X058	BRUSH
59	P0514X059	CAP SCREW M6-1 X 25
60	P0514X060	STAR HANDLE
61	P0514X061	LOCK NUT 6MM
62	P0514X062	STRAIN RELIEF 16MM
63	P0514X063	HEIGHT POINTER

REF	PART #	DESCRIPTION
64	P0514X064	HEX NUT M8-1.25
65	P0514X065	HEX BOLT M8-1.25 X 90
66	P0514X066	KNOB SCREW M10-1.5 X 20
67	P0514X067	KNOB SCREW M10-1.5 X 55
68	P0514X068	THREADED HANDLE 10MM
69	P0514X069	CAM
70	P0514X070	PILLOW BLOCK
71	P0514X071	HANDLE M10-1.5
72	P0514X072	LEVER ROD
73	P0514X073	HEX NUT M12-1.75
74	P0514X074	SHAFT
75	P0514X075	BUTTON HD CAP SCR M8-1.25 X 20
76	P0514X076	LOCK WASHER 8MM
78	P0514X078	COVER
79	P0514X079	SET SCREW M8-1.25 X 20
80	P0514X080	HEX NUT M8-1.25
81	P0514X081	LOWER WHEEL SHAFT
82	P0514X082	MOTOR 3HP 220V 1PH 60HZ
82-1	P0514X082-1	MOTOR FAN COVER
82-2	P0514X082-2	MOTOR FAN
82-3	P0514X082-3	CAPACITOR COVER
82-4V2	P0514X082-4V2	S CAPACITOR 300M 250V V2.05.11
82-5	P0514X082-5	CAPACITOR COVER
82-6V2	P0514X082-6V2	R CAPACITOR 60M 300V V2.02.11
82-7	P0514X082-7	MOTOR JUNCTION BOX
82-9	P0514X082-9	CENTRIFUGAL SWITCH W/ CONTACT PLATE
82-10	P0514X082-10	FRONT MOTOR BEARING
82-11	P0514X082-11	REAR MOTOR BEARING
83	P0514X083	HEX BOLT M10-1.5 X 25
84	P0514X084	LOCK WASHER 10MM
85	P0514X085	MOTOR BRACKET
86	P0514X086	BUTTON HD CAP SCR M8-1.25 X 20
87	P0514X087	PLATE
88	P0514X088	FLANGE SCREW M5-.8 X 10
89	P0514X089	PILLOW BLOCK
90	P0514X090	KEY 5 X 5 X 35
91	P0514X091	HEX BOLT M8-1.25 X 20 LH
92	P0514X092	MOTOR PULLEY
93	P0514X093	V-BELT A-42 4L420
94	P0514X094	CAP SCREW M6-1 X 10
95	P0514X095	LOWER WHEEL COVER
97	P0514X097	FENDER WASHER 8MM
137	P0514X137	CAP SCREW M6-1 X 20
161V2	P0514X161V2	MAG SWITCH ASSY 3HP 220V V2.05.11
161V2-1	P0514X161V2-1	SWITCH FRONT COVER
161V2-2	P0514X161V2-2	CONTACTOR SDE MA-18 220V
161V2-3	P0514X161V2-3	OL RELAY SDE RA-20 12-18A
161V2-4	P0514X161V2-4	SWITCH BACK COVER
163	P0514X163	FLANGE SCREW M5-.8 X 10
165	P0514X165	CONTROL CORD 16G 3W
166	P0514X166	MOTOR CORD 14G 3W
168	P0514X168	CORD CLAMP
169	P0514X169	FLANGE SCREW M5-.8 X 12
172	P0514X172	LOCK WASHER 8MM
182	P0514X182	POWER CORD 14G 3W 6-15



G0514X Fence/Guides

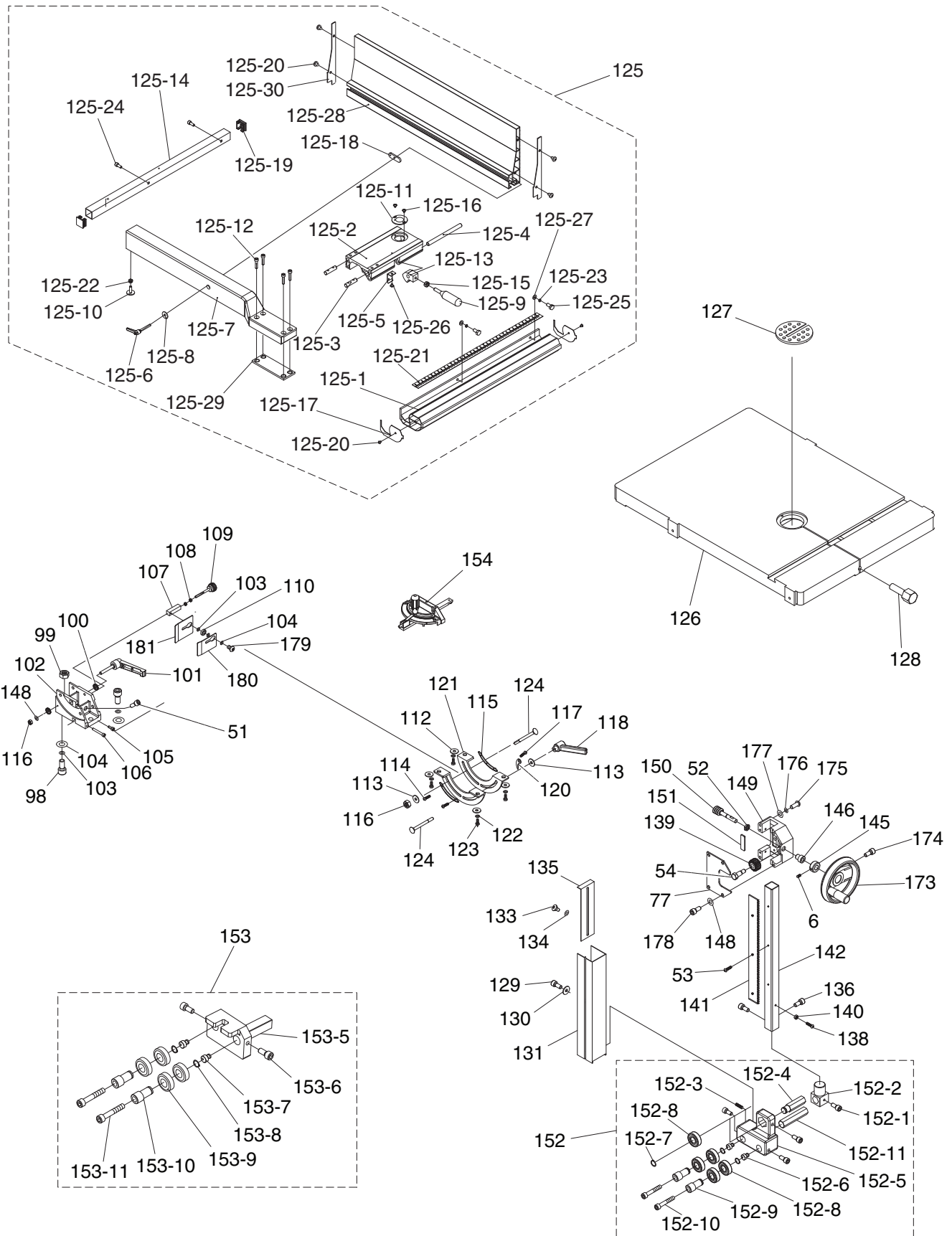

G0514X Fence/Guide Parts List

REF	PART #	DESCRIPTION
6	P0514X006	SET SCREW M5-.8 X 5
51	P0514X051	CAP SCREW M6-1 X 20
52	P0514X052	WORM SHAFT THIN NUT
53	P0514X053	FLAT HD SCR M4-.7 X 8
54	P0514X054	STEP BOLT M8-1.25 X 80
77	P0514X077	COVER
98	P0514X098	CAP SCREW M10-1.5 X 35
99	P0514X099	HEX NUT M10-1.5
100	P0514X100	SMALL GEAR
101	P0514X101	LOCK HANDLE
102	P0514X102	TRUNNION SUPPORT BRACKET
103	P0514X103	LOCK WASHER 10MM
104	P0514X104	FLAT WASHER 10MM
105	P0514X105	HEX BOLT M6-1 X 20
106	P0514X106	CAP SCREW M6-1 X 45
107	P0514X107	PILLOW BLOCK
108	P0514X108	HEX NUT M6-1
109	P0514X109	ADJUST BOLT M6
110	P0514X110	BALL BEARING 6000ZZ
112	P0514X112	FLAT WASHER 8MM
113	P0514X113	FLAT WASHER 8MM
114	P0514X114	PHLP HD SCR M4-.7 X 6
115	P0514X115	GEAR PLATE
116	P0514X116	LOCK NUT M8-1.25
117	P0514X117	PHLP HD SCR M4-.7 X 6
118	P0514X118	LOCK HANDLE
120	P0514X120	POINTER
121	P0514X121	TRUNNION
122	P0514X122	LOCK WASHER 8MM
123	P0514X123	HEX BOLT M8-1.25 X 16
124	P0514X124	CARRIAGE BOLT M8-1.25 X 80
125	P0514X125	FENCE ASSEMBLY
125-1	P0514X125-1	FIXED BASE 710MM
125-2	P0514X125-2	ADJUST BASE
125-3	P0514X125-3	FIXED SHAFT
125-4	P0514X125-4	SHAFT
125-5	P0514X125-5	SPRING PIECE
125-6	P0514X125-6	ADJUSTMENT HANDLE M8 X 44
125-7	P0514X125-7	SUPPORT TUBE 640MM
125-8	P0514X125-8	FLAT WASHER 8MM
125-9	P0514X125-9	FENCE HANDLE M8-1.25 X 22
125-10	P0514X125-10	RAIL PAD ADJUSTMENT SCREW
125-11	P0514X125-11	CONVEX
125-12	P0514X125-12	CAP SCREW M6-1 X 25
125-13	P0514X125-13	FIXED LUMP
125-14	P0514X125-14	REAR RAIL 710MM
125-15	P0514X125-15	HEX NUT M8-1.25
125-16	P0514X125-16	FLANGE SCREW M4-.7 X 6
125-17	P0514X125-17	GUARD PIECE
125-18	P0514X125-18	MOVING PLATE
125-19	P0514X125-19	PLUGGED
125-20	P0514X125-20	TAP SCREW M3.5 X 8
125-21	P0514X125-21	SCALE
125-22	P0514X125-22	HEX NUT M6-1
125-23	P0514X125-23	LOCK WASHER 6MM
125-24	P0514X125-24	CAP SCREW M6-1 X 16
125-25	P0514X125-25	HEX BOLT M6-1 X 20

REF	PART #	DESCRIPTION
125-26	P0514X125-26	FLANGE BOLT M4-.7 X 8
125-27	P0514X125-27	FLAT WASHER 6MM
125-28	P0514X125-28	RESAW FENCE AL 640MM
125-29	P0514X125-29	SPACER PLATE
125-30	P0514X125-30	RESAW FENCE END PLATE
126	P0514X126	TABLE 26-3/4" X 19"
127	P0514X127	TABLE INSERT
128	P0514X128	TABLE PIN
129	P0514X129	CAP SCREW M5-.8 X 10
130	P0514X130	FLAT WASHER 5MM
131	P0514X131	GUIDE POST COVER
133	P0514X133	SHOULDER SCREW
134	P0514X134	FIBER WASHER 13MM
135	P0514X135	SLIDING PLATE
136	P0514X136	CAP SCREW M6-1 X 16
138	P0514X138	PHLP HD SCR M4-.7 X 10
139	P0514X139	GEAR
140	P0514X140	HEX NUT M4-.7
141	P0514X141	RACK
142	P0514X142	UPPER GUIDE TUBE
145	P0514X145	LOCK COLLAR
146	P0514X146	BUSHING
148	P0514X148	LOCK WASHER 8MM
149	P0514X149	GUIDE BRACKET
150	P0514X150	WORM CYLINDER
151	P0514X151	FIXED PLATE
152	P0514X152	UPPER BLADE GUIDE ASSEMBLY
152-1	P0514X152-1	CAP SCREW M6-1 X 16
152-2	P0514X152-2	UPPER GUIDE SUPPORT BLOCK
152-3	P0514X152-3	SET SCREW M6-1 X 10
152-4	P0514X152-4	ADJUST BAR
152-5	P0514X152-5	UPPER BLADE GUIDE SUPPORT
152-6	P0514X152-6	BIAS SHAFT
152-7	P0514X152-7	EXT RETAINING RING 15MM
152-8	P0514X152-8	BALL BEARING 6202 ZZ
152-9	P0514X152-9	HANDLE BUSHING
152-10	P0514X152-10	CAP SCREW M6-1 X 35
152-11	P0514X152-11	UPPER SPACING SLEEVE
153	P0514X153	LOWER BLADE GUIDE ASSEMBLY
153-5	P0514X153-5	LOWER BLADE GUIDE SUPPORT
153-6	P0514X153-6	CAP SCREW M6-1 X 16
153-7	P0514X153-7	BIAS SHAFT
153-8	P0514X153-8	EXT RETAINING RING 15MM
153-9	P0514X153-9	BALL BEARING 6202 ZZ
153-10	P0514X153-10	HANDLE BUSHING
153-11	P0514X153-11	CAP SCREW M6-1 X 35
154	P0514X154	MITER GAUGE ASSEMBLY
173	P0514X173	GUIDE POST HANDWHEEL
174	P0514X174	CAP SCREW M6-1 X 20
175	P0514X175	BUTTON HD CAP SCR M8-1.25 X 20
176	P0514X176	LOCK WASHER 8MM
177	P0514X177	FLAT WASHER 8MM
178	P0514X178	CAP SCREW M8-1.25 X 16
179	P0514X179	BUTTON HD CAP SCR M10-1.5 X 20
180	P0514X180	RIGHT CLAMP PLATE
181	P0514X181	LEFT CLAMP PLATE



G0514X Labels & Parts List

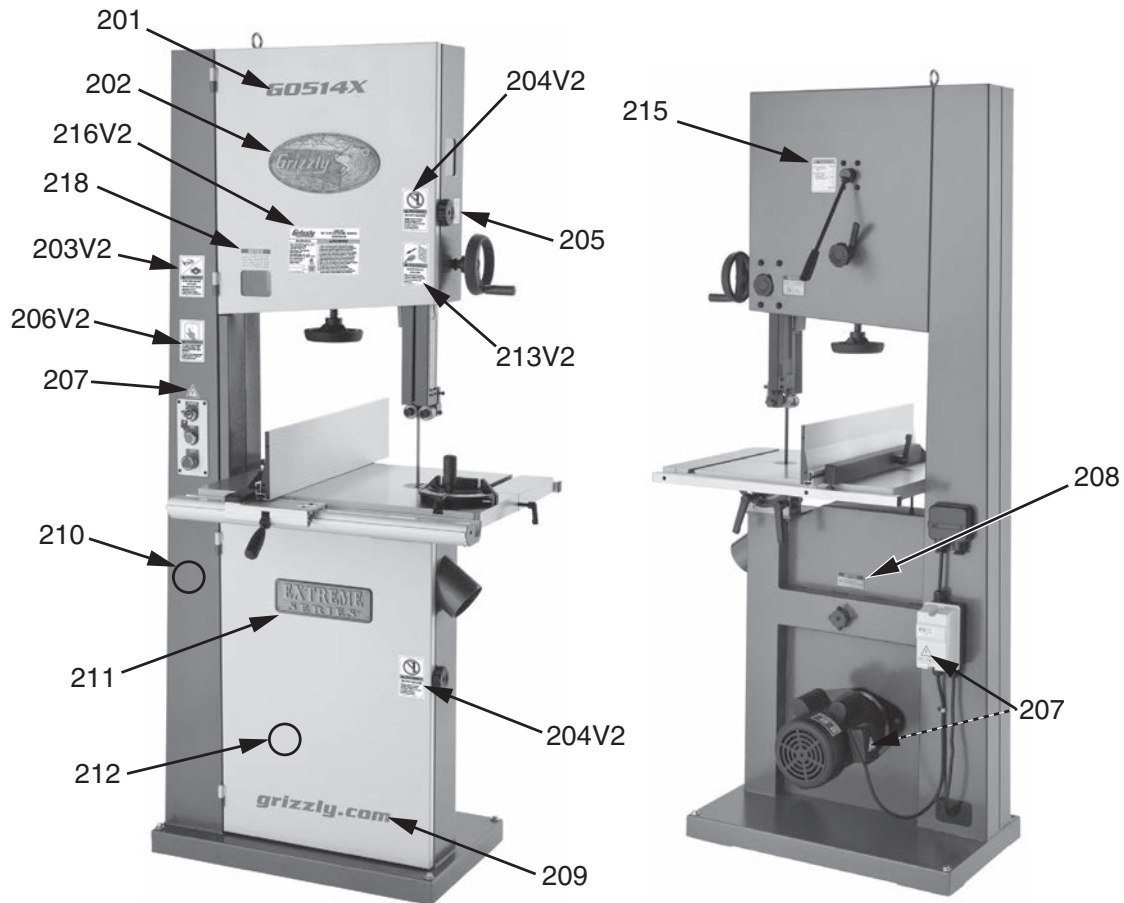

REF	PART #	DESCRIPTION
201	P0514X201	MODEL NUMBER LABEL
202	P0514X202	GRIZZLY LOGO PLATE
203V2	P0514X203V2	GLASSES/RESPIRATOR LABEL V2.08.13
204V2	P0514X204V2	OPEN DOOR LABEL V2.08.13
205	P0514X205	GUARD ADJ LABEL
206V2	P0514X206V2	READ MANUAL LABEL V2.08.13
207	P0514X207	ELECTRICITY LABEL
208	P0514X208	TABLE LOCK LEVER LABEL

REF	PART #	DESCRIPTION
209	P0514X209	GRIZZLY.COM LABEL
210	P0514X210	TOUCH-UP PAINT, GRIZZLY GREEN
211	P0514X211	EXTREME SERIES NAMEPLATE
212	P0514X212	TOUCH-UP PAINT, PUTTY
213V2	P0514X213V2	DISCONNECT POWER LABEL V2.08.13
215	P0514X215	TENSION ADJ LABEL
216V2	P0514X216V2	MACHINE ID LABEL V2.02.12
218	P0514X218	BLADE TENSION LABEL

WARNING

Safety labels warn about machine hazards and ways to prevent injury. The owner of this machine **MUST** maintain the original location and readability of the labels on the machine. If any label is removed or becomes unreadable, **REPLACE** that label before using the machine again. Contact Grizzly at (800) 523-4777 or www.grizzly.com to order new labels.



G0514X2 & G0514X3 Main Parts List

REF	PART #	DESCRIPTION
1	P0514X2001	SET SCREW M6-1 X 10
2	P0514X2002	FLANGE SCREW M5-.8 X 10
3	P0514X2003	BUSHING
4	P0514X2004	LIFTING EYE BOLT M10-1.5
5	P0514X2005	MACHINE BODY
7	P0514X2007	BUSHING
8	P0514X2008	FLAT WASHER 6MM
10	P0514X2010	HEX NUT M6-1
11	P0514X2011	TENSION POINTER
12	P0514X2012	STEP SCREW M4-.7 X 5
13	P0514X2013	SLEEVE
14	P0514X2014	ROLL PIN 5 X 35
15	P0514X2015	UPPER WHEEL SHAFT HINGE
16	P0514X2016	UPPER WHEEL SHAFT
17	P0514X2017	BUSHING
18	P0514X2018	BALL BEARING 6204 2RS
19	P0514X2019	UPPER WHEEL 19"
20	P0514X2020	INT RETAINING RING 47MM
21	P0514X2021	WHEEL FLAT WASHER 8MM
22	P0514X2022	CAP SCREW M8-1.25 X 16
23	P0514X2023	BLADE 6TPI HOOK 143"
24	P0514X2024	LOCK WASHER 8MM
25	P0514X2025	CAP SCREW M8-1.25 X 20
26	P0514X2026	URETHANE TIRE (PAIR)
27	P0514X2027	LOWER WHEEL 19"
28	P0514X2028	IDLER PULLEY
29	P0514X2029	HEX NUT 1-14
30	P0514X2030	LOCK WASHER 1"
32	P0514X2032	COMPRESSION SPRING 7 X 8 X 90
33	P0514X2033	ROLL PIN 3 X 16
34	P0514X2034	SPRING BASE PLATE
35	P0514X2035	THRUST BEARING 51201
37	P0514X2037	TENSION HANDWHEEL
38	P0514X2038	ADJUSTMENT SHAFT
39	P0514X2039	CONTROL PANEL
40	P0514X2040	TAP SCREW M4 X 10
41	P0514X2041	KEYED POWER SWITCH
42	P0514X2042	ON BUTTON
43	P0514X2043	OFF BUTTON
44	P0514X2044	CAP SCREW M8-1.25 X 16
45	P0514X2045	FENDER WASHER 8MM
46	P0514X2046	UPPER WHEEL SLIDING BRACKET
47	P0514X2047	CAP SCREW M6-1 X 90
48	P0514X2048	STEEL BLIND RIVET 3 X 10MM
49	P0514X2049	CAP SCREW M6-1 X 12
50	P0514X2050	CLEAR WINDOW
55	P0514X2055	WHEEL COVER UPPER
56	P0514X2056	CAP SCREW M6-1 X 25
57	P0514X2057	FLAT WASHER 6MM
58	P0514X2058	WHEEL BRUSH
59	P0514X2059	CAP SCREW M6-1 X 25
60	P0514X2060	STAR HANDLE

REF	PART #	DESCRIPTION
61	P0514X2061	LOCK NUT M6-1
62	P0514X2062	STRAIN RELIEF 16MM
63	P0514X2063	HEIGHT POINTER
64	P0514X2064	HEX NUT M8-1.25
65	P0514X2065	HEX BOLT M8-1.25 X 90
66	P0514X2066	KNOB BOLT M10-1.5 X 20
67	P0514X2067	KNOB BOLT M10-1.5 X 53
68	P0514X2068	THREADED HANDLE 10MM
69	P0514X2069	CAM
70	P0514X2070	HUB BRACKET
71	P0514X2071	KNOB
72	P0514X2072	LEVER
73	P0514X2073	HEX NUT M12-1.75
74	P0514X2074	LEVER HUB
75	P0514X2075	BUTTON HD CAP SCR M8-1.25 X 20
76	P0514X2076	LOCK WASHER 8MM
78	P0514X2078	SHAFT END CAP
79	P0514X2079	SET SCREW M8-1.25 X 20
80	P0514X2080	HEX NUT M8-1.25
81	P0514X2081	LOWER WHEEL SHAFT
83	P0514X2083	HEX BOLT M10-1.5 X 25
84	P0514X2084	LOCK WASHER 10MM
85	P0514X2085	MOTOR MOUNT PLATE
86	P0514X2086	BUTTON HD CAP SCR M8-1.25 X 20
87	P0514X2087	PLATE
88	P0514X2088	FLANGE SCREW M5-.8 X 10
89	P0514X2089	GUIDE KEY
90	P0514X2090	KEY 5 X 5 X 35
91	P0514X2091	HEX BOLT M8-1.25 X 20 LH
92	P0514X2092	MOTOR PULLEY
93	P0514X2093	V-BELT A42
94	P0514X2094	CAP SCREW M6-1 X 10
95	P0514X2095	LOWER WHEEL COVER
96	P0514X2096	CAP SCREW M6-1 X 16
97	P0514X2097	FENDER WASHER 8MM
98	P0514X2098	BRAKE LEVER
99	P0514X2099	BRAKE PAD
100	P0514X2100	BUSHING
101	P0514X2101	CAP SCREW M8-1.25 X 25
102	P0514X2102	CAP SCREW M6-1 X 25
103	P0514X2103	LOCK WASHER 6MM
104	P0514X2104	BUSHING
105	P0514X2105	BRAKE PEDAL PAD
106	P0514X2106	EXTENSION SPRING
107	P0514X2107	HEX NUT M4-.7
108	P0514X2108	TAP SCREW M4 X 8
109	P0514X2109	CORD CLAMP 5/8"
110V2	P0514X2110V2	BRAKE SWITCH CORD V2.05.11
112	P0514X2112	PHLP HD SCR M4-.7 X 30
113	P0514X2113	BRAKE SWITCH KL7141
114	P0514X2114	CORD CONDUIT 1/2" X 43-5/16"
115	P0514X2115	STRAIN RELIEF



G0514X2 & G0514X3 Main Parts List

REF	PART #	DESCRIPTION
119	P0514X2119	LOCK WASHER 8MM
137	P0514X2137	CAP SCREW M6-1 X 20
163	P0514X2163	FLANGE SCREW M5-.8 X 10
165	P0514X2165	CONTROL CORD 16G 3W
166	P0514X2166	MOTOR CORD 14G 3W
166	P0514X2166	MOTOR CORD 14G 4W

REF	PART #	DESCRIPTION
168	P0514X2168	CORD CLAMP
169	P0514X2169	FLANGE SCREW M5-.8 X 12
173	P0514X2173	STRAIN RELIEF 9 X 10MM
174	P0514X2174	SET BOLT M7-1 X 10 NYLON
175	P0514X2175	SPACER NYLON
182	P0514X2182	POWER CORD 14AWG 3C 6-15 (G0514X2)

G0514X3 Power Connection Junction Box

REF	PART #	DESCRIPTION
155	P0514X2155	FLANGE SCREW M5-.8 X 50
156	P0514X2156	TERMINAL BOX
162	P0514X2162	PHLP HD SCR M4-.7 X 10

REF	PART #	DESCRIPTION
167V2	P0514X2167V2	GROUNDING WIRE 90MM V2.05.11
170	P0514X2170	EXT TOOTH WASHER 5MM
171	P0514X2171	WIRE NUT P3

G0514X2 220V Motor

REF	PART #	DESCRIPTION
82	P0514X2082	MOTOR 3HP 220V 1PH 60HZ
82-1	P0514X2082-1	MOTOR FAN COVER
82-2	P0514X2082-2	MOTOR FAN
82-3	P0514X2082-3	START CAPACITOR COVER
82-4V2	P0514X2082-4V2	S CAPACITOR 300M 250V V2.05.11
82-5	P0514X2082-5	R CAPACITOR COVER

REF	PART #	DESCRIPTION
82-6V2	P0514X2082-6V2	R CAPACITOR 60M 300V V2.05.11
82-7	P0514X2082-7	MOTOR JUNCTION BOX
82-9	P0514X2082-9	CENTRIFUGAL SWITCH W/ CONTACT PLATE
82-10	P0514X2082-10	FRONT MOTOR BEARING
82-11	P0514X2082-11	REAR MOTOR BEARING

G0514X3 220V Motor

REF	PART #	DESCRIPTION
82V2	P0514X3082V2	MOTOR 3HP 220/440V 3PH V2.05.11
82V2-1	P0514X3082V2-1	MOTOR FAN COVER
82V2-2	P0514X3082V2-2	MOTOR FAN

REF	PART #	DESCRIPTION
82V2-7	P0514X3082V2-7	MOTOR JUNCTION BOX
82V2-10	P0514X3082V2-10	FRONT MOTOR BEARING
82V2-11	P0514X3082V2-11	REAR MOTOR BEARING

G0514X2 220V Magnetic Switch

REF	PART #	DESCRIPTION
161	P0514X161	MAG SWITCH ASSY 3HP 1PH 220V
161-1	P0514X2161-1	MAG SWITCH BACK COVER
161-2	P0514X2161-2	CONTACTOR SDE MA-18

REF	PART #	DESCRIPTION
161-3	P0514X2161-3	OL RELAY SDE RA-20 12-18A
161-4	P0514X2161-4	MAG SWITCH FRONT COVER

G0514X3 220V Magnetic Switch

REF	PART #	DESCRIPTION
161	P0514X3161	MAG SWITCH ASSY 220V
161-1	P0514X3161-1	SWITCH BACK COVER 220V
161-2	P0514X3161-2	CONTACTOR SDE MA-09 220V

REF	PART #	DESCRIPTION
161-3	P0514X3161-3	OL RELAY SDE RA-20 8-12A
161-4	P0514X3161-4	SWITCH FRONT COVER 220V

G0514X3 440V Magnetic Switch

REF	PART #	DESCRIPTION
161AV2	P0514X3161AV2	MAG SWITCH ASSY 440V V2.05.11
161AV2-1	P0514X3161AV2-1	MAG SWITCH BACK COVER
161AV2-2	P0514X3161AV2-2	CONTACTOR SDE MA-09 440V

REF	PART #	DESCRIPTION
161AV2-3	P0514X3161AV2-3	OL RELAY SDE RA-20 5-8A
161AV2-4	P0514X3161AV2-4	MAG SWITCH FRONT COVER



G0514X2 & G0514X3 Fence & Guides Parts List

REF	PART #	DESCRIPTION
6	P0514X2006	TRUNNION ASSEMBLY
6-1	P0514X2006-1	FENDER WASHER 8MM
6-2	P0514X2006-2	LOCK NUT M8-1.25
6-3	P0514X2006-3	CARRIAGE BOLT M8-1.25 X 85
6-4	P0514X2006-4	TRUNNION
6-5	P0514X2006-5	CARRIAGE BOLT M8-1.25 X 80
6-6	P0514X2006-6	LOCK HANDLE
6-7	P0514X2006-7	ANGLE SCALE
6-8	P0514X2006-8	FLAT WASHER 8MM
6-9	P0514X2006-9	HEX BOLT M8-1.25 X 25
6-10	P0514X2006-10	FLAT WASHER 4MM
6-11	P0514X2006-11	TILT POINTER
6-12	P0514X2006-12	PHLP HD SCR M4-.7 X 6
6-13	P0514X2006-13	ADJUSTMENT KNOB BOLT M6-1
6-14	P0514X2006-14	HEX NUT M6-1
6-15	P0514X2006-15	L-BRACKET
6-16	P0514X2006-16	FLAT HD SCR M5-.8 X 16
6-17	P0514X2006-17	CAP SCREW M6-1 X 16
6-18	P0514X2006-18	CAP SCREW M6-1 X 50
6-19	P0514X2006-19	TRUNNION SUPPORT BRACKET
6-20	P0514X2006-20	BUTTON HD CAP SCR M10-1.5 X 30
6-21	P0514X2006-21	RIGHT CLAMP PLATE
6-22	P0514X2006-22	BALL BEARING 6000ZZ
6-23	P0514X2006-23	FLAT WASHER 10MM
6-24	P0514X2006-24	LEFT CLAMP PLATE
6-25	P0514X2006-25	ADJUSTMENT BLOCK
6-26	P0514X2006-26	LOCK WASHER 8MM
6-27	P0514X2006-27	CAP SCREW M5-.8 X 6
6-28	P0514X2006-28	LOCK WASHER 8MM
6-29	P0514X2006-29	LOCK WASHER 10MM
9	P0514X2009	UPPER GUIDE POST ASSEMBLY
9-1	P0514X2009-1	SET SCREW M5-.8 X 5
9-2	P0514X2009-2	CAP SCREW M6-1 X 16
9-3	P0514X2009-3	PHLP HD SCR M4-.7 X 10
9-4	P0514X2009-4	HEX NUT M4-.7
9-5	P0514X2009-5	RACK
9-6	P0514X2009-6	GUIDE POST
9-7	P0514X2009-7	LOCK COLLAR
9-8	P0514X2009-8	BUSHING
9-9	P0514X2009-9	LOCK WASHER 8MM
9-10	P0514X2009-10	GUIDE POST BRACKET
9-11	P0514X2009-11	WORM SHAFT
9-12	P0514X2009-12	FIXED PLATE
9-13	P0514X2009-13	GEAR 15T
9-14	P0514X2009-14	GEAR STEP BOLT
9-15	P0514X2009-15	COVER PLATE
9-16	P0514X2009-16	CAP SCREW M8-1.25 X 16
9-17	P0514X2009-17	FLAT HD SCR M4-.7 X 8

REF	PART #	DESCRIPTION
9-18	P0514X2009-18	HEX NUT M16-1.5
9-19	P0514X2009-19	GUIDE BRACKET PLASTIC SET SCREW
24	P0514X2024	LOCK WASHER 8MM
25	P0514X2025	CAP SCREW M8-1.25 X 20
31	P0514X2031	TABLE TILT HANDWHEEL
36	P0514X2036	CAP SCREW M6-1 X 25
45	P0514X2045	FENDER WASHER 8MM
49	P0514X2049	CAP SCREW M6-1 X 12
51	P0514X2051	TABLE TILT BRACKET ASSEMBLY
51-1	P0514X2051-1	SQUARE TUBE
51-2	P0514X2051-2	GUIDE BRACKET
51-3	P0514X2051-3	WORM SHAFT
51-4	P0514X2051-4	HEX NUT M16-1.5
51-5	P0514X2051-5	BUSHING
51-6	P0514X2051-6	LOCK COLLAR 22 X 10 X 10MM
51-7	P0514X2051-7	SET SCREW M5-.8 X 5
51-8	P0514X2051-8	HEX NUT M5-.8
51-9	P0514X2051-9	LOCK WASHER 8MM
51-10	P0514X2051-10	CAP SCREW M8-1.25 X 16
51-11	P0514X2051-11	FLANGE SCREW M5-.8 X 10
51-12	P0514X2051-12	PINION GEAR COVER
51-13	P0514X2051-13	BRACKET COVER
51-14	P0514X2051-14	PINION GEAR STEP BOLT
51-15	P0514X2051-15	FLAT HD SCR M4-.7 X 8
51-16	P0514X2051-16	RACK
51-17	P0514X2051-17	PINION GEAR 15T
51-18	P0514X2051-18	PHLP HD SCR M4-.7 X 10
51-19	P0514X2051-19	HEX NUT M4-.7
51-20	P0514X2051-20	FIXED PLATE
103	P0514X2103	LOCK WASHER 6MM
116	P0514X2116	FLAT WASHER 6MM
117	P0514X2117	LOCK NUT M8-1.25
118	P0514X2118	SLIDING PLATE
120	P0514X2120	HEX BOLT M8-1.25 X 20
121	P0514X2121	TRUNNION PLATE
122	P0514X2122	CAP SCREW M8-1.25 X 55
125	P0514X2125	FENCE SET ASSEMBLY
125-1	P0514X2125-1	FRONT RAIL 720MM
125-2	P0514X2125-2	FENCE BASE
125-3	P0514X2125-3	ALIGNMENT ROD
125-4	P0514X2125-4	LOCK ROD
125-5	P0514X2125-5	LOCK PLATE
125-6	P0514X2125-6	LOCK HANDLE M8-1.25 X 44
125-7	P0514X2125-7	FENCE 640MM
125-8	P0514X2125-8	FLAT WASHER 8MM
125-9	P0514X2125-9	LOCK LEVER
125-10	P0514X2125-10	REAR FENCE STANDOFF
125-11	P0514X2125-11	SCALE WINDOW



G0514X2 & G0514X3 Fence & Guides Parts List

REF	PART #	DESCRIPTION
125-12	P0514X2125-12	CAP SCREW M6-1 X 25
125-13	P0514X2125-13	LOCK WEDGE
125-14	P0514X2125-14	REAR RAIL 710MM
125-15	P0514X2125-15	HEX NUT M8-1.25
125-16	P0514X2125-16	FLANGE SCREW M4-.7 X 6
125-17	P0514X2125-17	FRONT RAIL END PLATE
125-18	P0514X2125-18	GUIDE PLATE
125-19	P0514X2125-19	REAR RAIL END PLUG
125-20	P0514X2125-20	TAP SCREW M3.5 X 8
125-21	P0514X2125-21	SCALE 21-1/2"
125-22	P0514X2125-22	HEX NUT M6-1
125-23	P0514X2125-23	LOCK WASHER 6MM
125-24	P0514X2125-24	CAP SCREW M6-1 X 16
125-25	P0514X2125-25	HEX BOLT M6-1 X 20
125-26	P0514X2125-26	FLANGE BOLT M4-.7 X 8
125-27	P0514X2125-27	FLAT WASHER 6MM
125-28	P0514X2125-28	RESAW FENCE 640MM ALUMINUM
125-29	P0514X2125-29	FENCE BASE PLATE
125-30	P0514X2125-30	RESAW FENCE END PLATE
126	P0514X2126	TABLE 27 X 19"
127	P0514X2127	TABLE INSERT
128	P0514X2128	TABLE PIN
129	P0514X2129	CAP SCREW M5-.8 X 10
130	P0514X2130	FLAT WASHER 5MM
131	P0514X2131	GUIDE POST COVER
132	P0514X2132	STEP SCREW
133	P0514X2133	SLIDING COVER
134	P0514X2134	FIBER FLAT WASHER
143	P0514X2143	GUIDE POST HANDWHEEL

REF	PART #	DESCRIPTION
144	P0514X2144	CAP SCREW M6-1 X 20
152	P0514X2152	UPPER BLADE GUIDE ASSEMBLY
152-1	P0514X2152-1	CAP SCREW M6-1 X 16
152-2	P0514X2152-2	GUIDE POST CONNECTOR
152-3	P0514X2152-3	SET SCREW M6-1 X 10
152-4	P0514X2152-4	BRACKET ROD
152-5	P0514X2152-5	UPPER BLADE GUIDE BRACKET
152-6	P0514X2152-6	BIAS SHAFT
152-7	P0514X2152-7	EXT RETAINING RING 15MM
152-8	P0514X2152-8	BALL BEARING 6202ZZ
152-9	P0514X2152-9	BEARING BUSHING
152-10	P0514X2152-10	CAP SCREW M6-1 X 35
152-11	P0514X2152-11	ADJUSTMENT ROD
153	P0514X2153	LOWER BLADE GUIDE ASSEMBLY
153-5	P0514X2153-5	GUIDE BRACKET CONNECTOR
153-6	P0514X2153-6	CAP SCREW M6-1 X 16
153-7	P0514X2153-7	BIAS SHAFT
153-8	P0514X2153-8	EXT RETAINING RING 15MM
153-9	P0514X2153-9	BALL BEARING 6202ZZ
153-10	P0514X2153-10	BEARING BUSHING
153-11	P0514X2153-11	CAP SCREW M6-1 X 35
154	P0514X2154	MITER GAUGE ASSEMBLY
176	P0514X2176	CAP SCREW M10-1.5 X 35
177	P0514X2177	LOCK WASHER 10MM
178	P0514X2178	FLAT WASHER 10MM
179	P0514X2179	BUTTON HD CAP SCR M8-1.25 X 30
180	P0514X2180	LOCK WASHER 8MM
181	P0514X2181	FLAT WASHER 8MM



G0514X2 & G0514X3 Labels

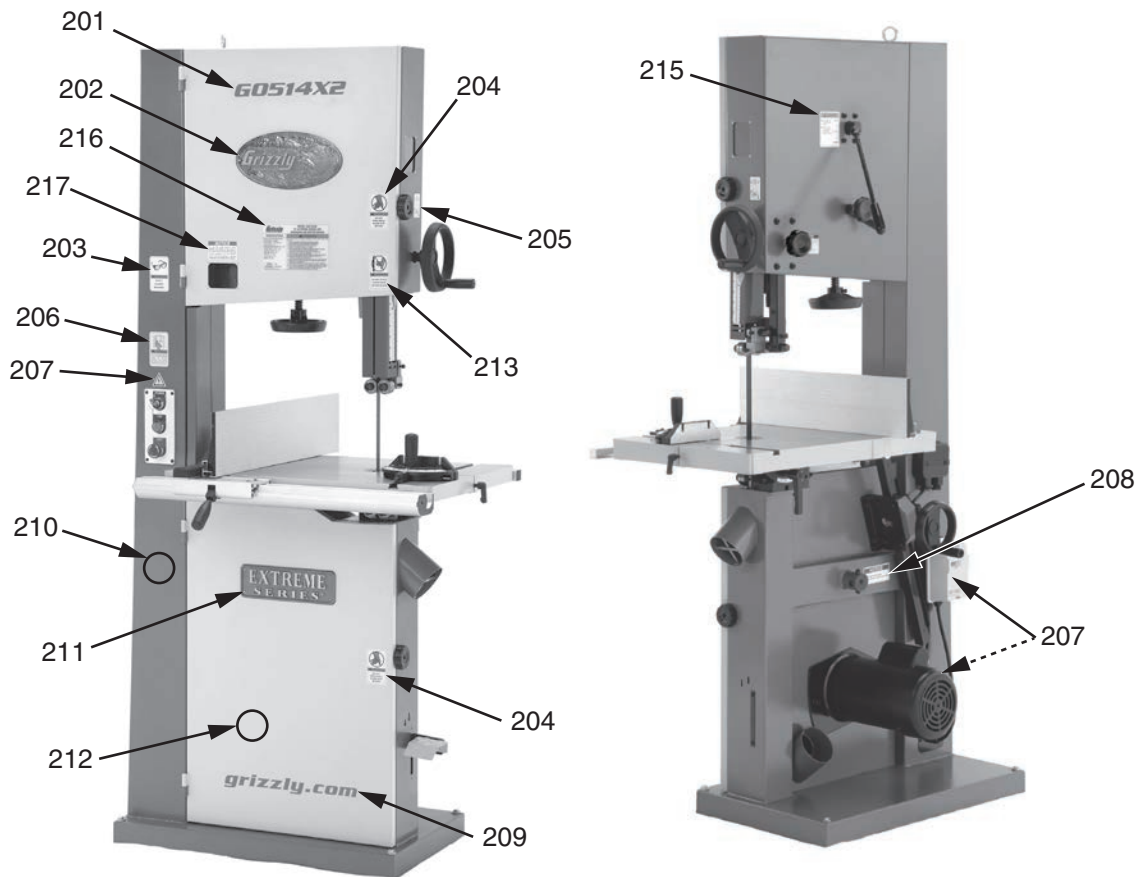

REF	PART #	DESCRIPTION
201	P0514X2201	MODEL NUMBER LABEL
202	P0514X2202	GRIZZLY LOGO PLATE
203	P0514X2203	GLASSES/RESPIRATOR LABEL
204	P0514X2204	OPEN DOOR LABEL
205	P0514X2205	GUARD ADJ LABEL
206	P0514X2206	READ MANUAL LABEL
207	P0514X2207	ELECTRICITY LABEL
208	P0514X2208	TABLE LOCK LEVER LABEL

REF	PART #	DESCRIPTION
209	P0514X2209	GRIZZLY.COM LABEL
210	P0514X2210	TOUCH-UP PAINT, GRIZZLY GREEN
211	P0514X2211	EXTREME SERIES NAMEPLATE
212	P0514X2212	TOUCH-UP PAINT, PUTTY
213	P0514X2213	DISCONNECT POWER LABEL
215	P0514X2215	TENSION ADJ LABEL
216	P0514X2216	MACHINE ID LABEL
217	P0514X2217	GUIDE POST LOCK KNOB LABEL

WARNING

Safety labels warn about machine hazards and ways to prevent injury. The owner of this machine **MUST** maintain the original location and readability of the labels on the machine. If any label is removed or becomes unreadable, **REPLACE** that label before using the machine again. Contact Grizzly at (800) 523-4777 or www.grizzly.com to order new labels.



G0514X2B Main

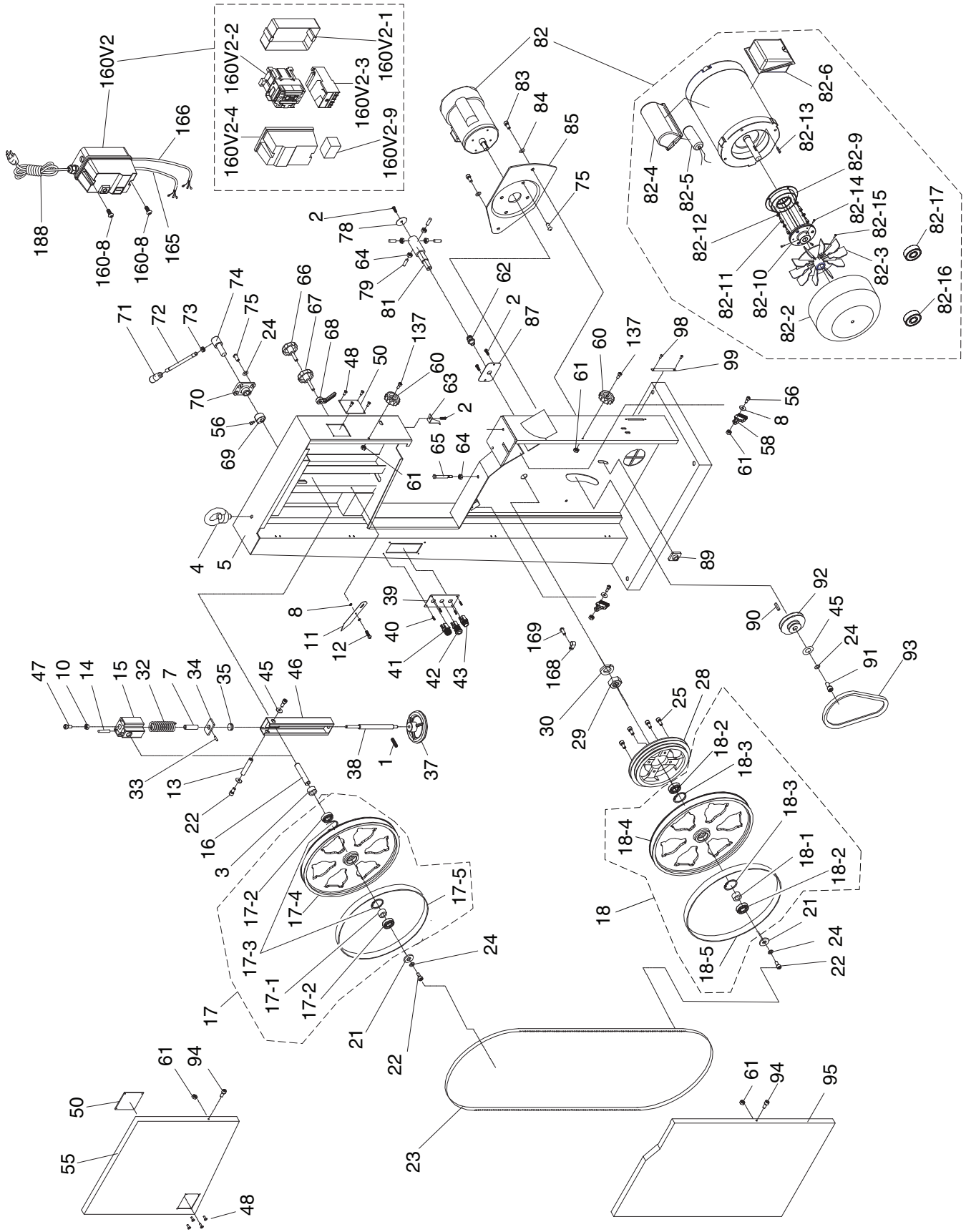

G0514X2B Main Parts List

REF	PART #	DESCRIPTION
1	P0514X2B001	SET SCREW M6-1 X 10
2	P0514X2B002	FLANGE SCREW M5-.8 X 10
3	P0514X2B003	BUSHING
4	P0514X2B004	LIFTING EYE BOLT M10-1.5
5	P0514X2B005	MACHINE BODY
7	P0514X2B007	BUSHING
8	P0514X2B008	FLAT WASHER 6MM
10	P0514X2B010	HEX NUT M6-1
11	P0514X2B011	TENSION POINTER
12	P0514X2B012	STEP SCREW M4-.7 X 5
13	P0514X2B013	SLEEVE
14	P0514X2B014	ROLL PIN 5 X 35
15	P0514X2B015	UPPER WHEEL SHAFT HINGE
16	P0514X2B016	UPPER WHEEL SHAFT
17	P0514X2B017	UPPER WHEEL ASSEMBLY
17-1	P0514X2B017-1	BUSHING
17-2	P0514X2B017-2	BALL BEARING 6204 2RS
17-3	P0514X2B017-3	INT RETAINING RING 47MM
17-4	P0514X2B017-4	UPPER WHEEL 19"
17-5	P0514X2B017-5	URETHANE TIRE (PAIR)
18	P0514X2B018	LOWER WHEEL ASSEMBLY
18-1	P0514X2B018-1	BUSHING
18-2	P0514X2B018-2	BALL BEARING 6204 2RS
18-3	P0514X2B018-3	INT RETAINING RING 47MM
18-4	P0514X2B018-4	WHEEL LOWER 19"
18-5	P0514X2B018-5	URETHANE TIRE (PAIR)
21	P0514X2B021	FLAT WASHER 8MM
22	P0514X2B022	CAP SCREW M8-1.25 X 16
23	P0514X2B023	BLADE 6TPI HOOK 143"
24	P0514X2B024	LOCK WASHER 8MM
25	P0514X2B025	CAP SCREW M8-1.25 X 20
28	P0514X2B028	IDLER PULLEY
29	P0514X2B029	HEX NUT 1-14
30	P0514X2B030	LOCK WASHER 1"
32	P0514X2B032	COMPRESSION SPRING 7 X 8 X 90
33	P0514X2B033	ROLL PIN 3 X 16
34	P0514X2B034	SPRING BASE PLATE
35	P0514X2B035	THRUST BEARING 51201
37	P0514X2B037	TENSION HANDWHEEL
38	P0514X2B038	ADJUSTING SHAFT
39	P0514X2B039	CONTROL PANEL
40	P0514X2B040	TAP SCREW M4 X 10
41	P0514X2B041	KEYED POWER SWITCH
42	P0514X2B042	ON BUTTON
43	P0514X2B043	OFF BUTTON
45	P0514X2B045	FENDER WASHER 8MM
46	P0514X2B046	UPPER WHEEL SLIDING BRACKET
47	P0514X2B047	CAP SCREW M6-1 X 90
48	P0514X2B048	STEEL BLIND RIVET 3 X 10MM
50	P0514X2B050	CLEAR WINDOW
55	P0514X2B055	UPPER WHEEL COVER
56	P0514X2B056	CAP SCREW M6-1 X 25
58	P0514X2B058	WHEEL BRUSH
60	P0514X2B060	STAR HANDLE
61	P0514X2B061	LOCK NUT M6-1
62	P0514X2B062	STRAIN RELIEF 16MM
63	P0514X2B063	HEIGHT POINTER

REF	PART #	DESCRIPTION
64	P0514X2B064	HEX NUT M8-1.25
65	P0514X2B065	HEX BOLT M8-1.25 X 90
66	P0514X2B066	KNOB BOLT M10-1.5 X 20
67	P0514X2B067	KNOB BOLT M10-1.5 X 53
68	P0514X2B068	THREADED HANDLE 10MM
69	P0514X2B069	CAM
70	P0514X2B070	HUB BRACKET
71	P0514X2B071	KNOB
72	P0514X2B072	LEVER
73	P0514X2B073	HEX NUT M12-1.75
74	P0514X2B074	LEVER HUB
75	P0514X2B075	BUTTON HD CAP SCR M8-1.25 X 20
78	P0514X2B078	SHAFT END CAP
79	P0514X2B079	SET SCREW M8-1.25 X 20
81	P0514X2B081	LOWER WHEEL SHAFT
82	P0514X2B082	MOTOR 3HP 220V 1PH W/BRAKE
82-2	P0514X2B082-2	MOTOR FAN COVER
82-3	P0514X2B082-3	MOTOR FAN
82-4	P0514X2B082-4	R CAPACITOR COVER
82-5	P0514X2B082-5	R CAPACITOR 50M 400V RUI JUN
82-6	P0514X2B082-6	MOTOR JUNCTION BOX
82-9	P0514X2B082-9	MOTOR MAGNETIC BRAKE
82-10	P0514X2B082-10	BRAKE SHOE
82-11	P0514X2B082-11	CAP SCREW M6-1 X 12
82-12	P0514X2B082-12	LOCK WASHER 6MM
82-13	P0514X2B082-13	KEY 5 X 5 X 25
82-14	P0514X2B082-14	CAP SCREW M5-.8 X 16
82-15	P0514X2B082-15	PHLP HD SCR M5-.8 X 20
82-16	P0514X2B082-16	FRONT MOTOR BEARING
82-17	P0514X2B082-17	REAR MOTOR BEARING
83	P0514X2B083	HEX BOLT M10-1.5 X 25
84	P0514X2B084	LOCK WASHER 10MM
85	P0514X2B085	MOTOR MOUNT PLATE
87	P0514X2B087	PLATE
89	P0514X2B089	GUIDE KEY
90	P0514X2B090	KEY 5 X 5 X 35
91	P0514X2B091	HEX BOLT M8-1.25 X 20 LH
92	P0514X2B092	MOTOR PULLEY
93	P0514X2B093	V-BELT A42
94	P0514X2B094	CAP SCREW M6-1 X 10
95	P0514X2B095	LOWER WHEEL COVER
98	P0514X2B098	FLANGE BOLT M5-.8 X 10
99	P0514X2B099	COVER
137	P0514X2B137	CAP SCREW M6-1 X 20
160V2	P0514X2B160V2	MAG SWITCH ASSEMBLY V2.05.11
160V2-1	P0514X2B160V2-1	SWITCH BACK COVER
160V2-2	P0514X2B160V2-2	CONTACTOR SDE MA-18 220V
160V2-3	P0514X2B160V2-3	OL RELAY SDE RA-20 12-18A
160V2-4	P0514X2B160V2-4	SWITCH FRONT COVER
160-8	P0514X2B160-8	FLANGE SCREW M5-.8 X 10
160V2-9	P0514X2B160V2-9	RECTIFIER PU-23-2
165	P0514X2B165	CONTROL CORD 16G 4W
166	P0514X2B166	MOTOR CORD 14G 5W
168	P0514X2B168	CORD CLAMP
169	P0514X2B169	FLANGE SCREW M5-.8 X 12
188	P0514X2B188	POWER CORD 14G 3W 6-15



G0514X2B Fence & Guides

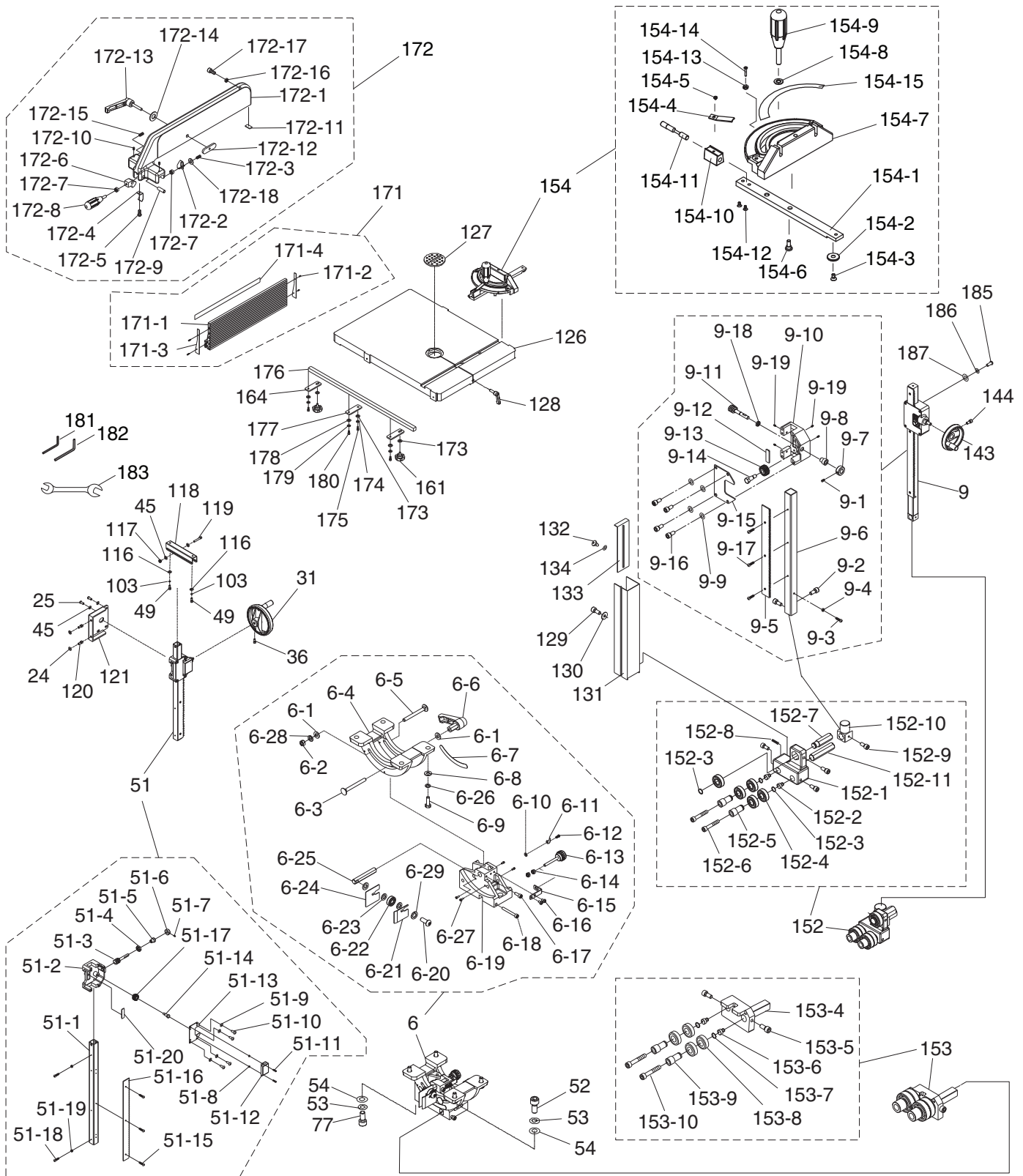

G0514X2B Fence & Guides Parts List

REF	PART #	DESCRIPTION
6	P0514X2B006	TRUNNION ASSEMBLY
6-1	P0514X2B006-1	FENDER WASHER 8MM
6-2	P0514X2B006-2	LOCK NUT M8-1.25
6-3	P0514X2B006-3	CARRIAGE BOLT M8-1.25 X 85
6-4	P0514X2B006-4	TRUNNION
6-5	P0514X2B006-5	CARRIAGE BOLT M8-1.25 X 80
6-6	P0514X2B006-6	LOCK HANDLE
6-7	P0514X2B006-7	ANGLE SCALE
6-8	P0514X2B006-8	FLAT WASHER 8MM
6-9	P0514X2B006-9	HEX BOLT M8-1.25 X 25
6-10	P0514X2B006-10	FLAT WASHER 4MM
6-11	P0514X2B006-11	TILT POINTER
6-12	P0514X2B006-12	PHLP HD SCR M4-.7 X 6
6-13	P0514X2B006-13	ADJUSTMENT KNOB BOLT M6-1
6-14	P0514X2B006-14	HEX NUT M6-1
6-15	P0514X2B006-15	L-BRACKET
6-16	P0514X2B006-16	FLAT HD SCR M5-.8 X 15
6-17	P0514X2B006-17	CAP SCREW M6-1 X 16
6-18	P0514X2B006-18	CAP SCREW M6-1 X 50
6-19	P0514X2B006-19	TRUNNION SUPPORT BRACKET
6-20	P0514X2B006-20	BUTTON HD CAP SCR M10-1.5 X 30
6-21	P0514X2B006-21	RIGHT CLAMP PLATE
6-22	P0514X2B006-22	BALL BEARING 6000ZZ
6-23	P0514X2B006-23	FLAT WASHER 10MM
6-24	P0514X2B006-24	LEFT CLAMP PLATE
6-25	P0514X2B006-25	ADJUSTMENT BLOCK
6-26	P0514X2B006-26	LOCK WASHER 8MM
6-27	P0514X2B006-27	CAP SCREW M5-.8 X 6
6-28	P0514X2B006-28	LOCK WASHER 8MM
6-29	P0514X2B006-29	LOCK WASHER 10MM
9	P0514X2B009	UPPER GUIDE POST ASSEMBLY
9-1	P0514X2B009-1	SET SCREW M5-.8 X 5
9-2	P0514X2B009-2	CAP SCREW M6-1 X 16
9-3	P0514X2B009-3	PHLP HD SCR M4-.7 X 10
9-4	P0514X2B009-4	HEX NUT M4-.7
9-5	P0514X2B009-5	RACK
9-6	P0514X2B009-6	GUIDE POST
9-7	P0514X2B009-7	LOCK COLLAR
9-8	P0514X2B009-8	BUSHING
9-9	P0514X2B009-9	LOCK WASHER 8MM
9-10	P0514X2B009-10	GUIDE POST BRACKET
9-11	P0514X2B009-11	WORM SHAFT
9-12	P0514X2B009-12	FIXED PLATE
9-13	P0514X2B009-13	GEAR 15T
9-14	P0514X2B009-14	GEAR STEP BOLT
9-15	P0514X2B009-15	BRACKET COVER
9-16	P0514X2B009-16	CAP SCREW M8-1.25 X 16
9-17	P0514X2B009-17	FLAT HD SCR M4-.7 X 8
9-18	P0514X2B009-18	BUSHING
9-19	P0514X2B009-19	BRACKET SET SCREW PLASTIC
24	P0514X2B024	LOCK WASHER 8MM
25	P0514X2B025	CAP SCREW M8-1.25 X 20
31	P0514X2B031	TABLE TILT HANDWHEEL

REF	PART #	DESCRIPTION
36	P0514X2B036	CAP SCREW M6-1 X 25
45	P0514X2B045	FENDER WASHER 8MM
49	P0514X2B049	CAP SCREW M6-1 X 10
51	P0514X2B051	TABLE TILT BRACKET ASSEMBLY
51-1	P0514X2B051-1	SQUARE TUBE
51-2	P0514X2B051-2	GUIDE BRACKET
51-3	P0514X2B051-3	WORM SHAFT
51-4	P0514X2B051-4	HEX NUT M16-1.5
51-5	P0514X2B051-5	BUSHING
51-6	P0514X2B051-6	LOCK COLLAR 22 X 10 X 10MM
51-7	P0514X2B051-7	SET SCREW M5-.8 X 5
51-8	P0514X2B051-8	HEX NUT M5-.8
51-9	P0514X2B051-9	LOCK WASHER 8MM
51-10	P0514X2B051-10	CAP SCREW M8-1.25 X 16
51-11	P0514X2B051-11	FLANGE SCREW M5-.8 X 10
51-12	P0514X2B051-12	PINION GEAR COVER
51-13	P0514X2B051-13	BRACKET COVER
51-14	P0514X2B051-14	PINION GEAR STEP BOLT
51-15	P0514X2B051-15	FLAT HD SCR M4-.7 X 10
51-16	P0514X2B051-16	RACK
51-17	P0514X2B051-17	PINION GEAR 15T
51-18	P0514X2B051-18	PHLP HD SCR M4-.7 X 10
51-19	P0514X2B051-19	HEX NUT M4-.7
51-20	P0514X2B051-20	FIXED PLATE
52	P0514X2B052	CAP SCREW M10-1.5 X 35
53	P0514X2B053	LOCK WASHER 10MM
54	P0514X2B054	FLAT WASHER 10MM
77	P0514X2B077	CAP SCREW M10-1.5 X 35
103	P0514X2B103	LOCK WASHER 6MM
116	P0514X2B116	FLAT WASHER 6MM
117	P0514X2B117	LOCK NUT M8-1.25
118	P0514X2B118	SLIDING PLATE
119	P0514X2B119	HEX BOLT M8-1.25 X 55
120	P0514X2B120	CAP SCREW M8-1.25 X 20
121	P0514X2B121	TRUNNION PLATE
126	P0514X2B126	TABLE
127	P0514X2B127	TABLE INSERT
128	P0514X2B128	TABLE PIN
129	P0514X2B129	CAP SCREW M5-.8 X 10
130	P0514X2B130	FLAT WASHER 5MM
131	P0514X2B131	GUIDE POST COVER
132	P0514X2B132	STEP SCREW
133	P0514X2B133	POST COVER SLIDING PLATE
134	P0514X2B134	FIBER FLAT WASHER
143	P0514X2B143	ELEVATION HANDWHEEL
144	P0514X2B144	CAP SCREW M6-1 X 20
152	P0514X2B152	UPPER BLADE GUIDE ASSEMBLY
152-1	P0514X2B152-1	UPPER GUIDE BRACKET
152-2	P0514X2B152-2	BIAS SHAFT
152-3	P0514X2B152-3	EXT RETAINING RING 15MM
152-4	P0514X2B152-4	BALL BEARING 6202ZZ
152-5	P0514X2B152-5	BEARING BUSING
152-6	P0514X2B152-6	CAP SCREW M6-1 X 35



G0514X2B Fence & Guides Parts List

REF	PART #	DESCRIPTION
152-7	P0514X2B152-7	ADJUSTMENT SHAFT
152-8	P0514X2B152-8	SET SCREW M6-1 X 10
152-9	P0514X2B152-9	CAP SCREW M6-1 X 16
152-10	P0514X2B152-10	GUIDE POST CONNECTOR
152-11	P0514X2B152-11	BRACKET ROD
153	P0514X2B153	LOWER BLADE GUIDE ASSEMBLY
153-4	P0514X2B153-4	LOWER GUIDE BRACKET
153-5	P0514X2B153-5	CAP SCREW M6-1 X 16
153-6	P0514X2B153-6	BIAS SHAFT
153-7	P0514X2B153-7	EXT RETAINING RING 15MM
153-8	P0514X2B153-8	BALL BEARING 6202ZZ
153-9	P0514X2B153-9	BEARING BUSHING
153-10	P0514X2B153-10	CAP SCREW M6-1 X 35
154	P0514X2B154	MITER GAUGE ASSEMBLY
154-1	P0514X2B154-1	T-SLOT BAR
154-2	P0514X2B154-2	GUIDE PIECE
154-3	P0514X2B154-3	FLAT HD SCR M6-1 X 8
154-4	P0514X2B154-4	ALIGNMENT PLATE
154-5	P0514X2B154-5	PHLP HD SCR 10-24 X 3/16
154-6	P0514X2B154-6	SHOULDER SCREW
154-7	P0514X2B154-7	MITER GAUGE BODY
154-8	P0514X2B154-8	FLAT WASHER 8MM
154-9	P0514X2B154-9	MITER GAUGE HANDLE
154-10	P0514X2B154-10	ALIGNMENT BLOCK
154-11	P0514X2B154-11	ALIGNMENT PIN
154-12	P0514X2B154-12	PHLP HD SCR 10-24 X 3/16
154-13	P0514X2B154-13	HEX NUT M4-.7
154-14	P0514X2B154-14	PHLP HD SCR M4-.7 X 16
154-15	P0514X2B154-15	MITER GAUGE SCALE
161	P0514X2B161	KNOB SCREW M8-1.25 X 20
164	P0514X2B164	OUTER RAIL PLATE
171	P0514X2B171	RESAW FENCE ASSEMBLY
171-1	P0514X2B171-1	RESAW FENCE 590MM ALUMINUM
171-2	P0514X2B171-2	TAP SCREW M3.5 X 8
171-3	P0514X2B171-3	RESAW FENCE END PLATE

REF	PART #	DESCRIPTION
171-4	P0514X2B171-4	SCALE
172	P0514X2B172	FENCE ASSEMBLY
172-1	P0514X2B172-1	FENCE
172-2	P0514X2B172-2	POINTER
172-3	P0514X2B172-3	FLANGE SCREW M5-.8 X 25
172-4	P0514X2B172-4	LOCK PLATE
172-5	P0514X2B172-5	FLANGE SCREW M4-.7 X 8
172-6	P0514X2B172-6	PIVOT BLOCK
172-7	P0514X2B172-7	HEX NUT M8-1.25
172-8	P0514X2B172-8	HANDLE
172-9	P0514X2B172-9	LOCK ROD
172-10	P0514X2B172-10	STANDOFF SET SCREW PLASTIC
172-11	P0514X2B172-11	NYLON PAD
172-12	P0514X2B172-12	GUIDE KEY
172-13	P0514X2B172-13	LOCK HANDLE M8-1.25 X 45
172-14	P0514X2B172-14	FLAT WASHER 8MM
172-15	P0514X2B172-15	SET SCREW M8-1.25 X 12
172-16	P0514X2B172-16	HEX NUT M8-1.25
172-17	P0514X2B172-17	CAP SCREW M8-1.25 X 20
172-18	P0514X2B172-18	FLAT WASHER 8MM
173	P0514X2B173	FLAT WASHER 8MM
174	P0514X2B174	LOCK WASHER 8MM
175	P0514X2B175	CAP SCREW M8-1.25 X 20
176	P0514X2B176	FENCE RAIL
177	P0514X2B177	INNER RAIL PLATE
178	P0514X2B178	FLAT WASHER 6MM
179	P0514X2B179	LOCK WASHER 6MM
180	P0514X2B180	CAP SCREW M6-1 X 20
181	P0514X2B181	WRENCH HEX 5MM
182	P0514X2B182	WRENCH HEX 8MM
183	P0514X2B183	WRENCH 10 X 13
185	P0514X2B185	BUTTON HD CAP SCR M8-1.25 X 30
186	P0514X2B186	LOCK WASHER 8MM
187	P0514X2B187	FENDER WASHER 8MM



G0514X2B Labels

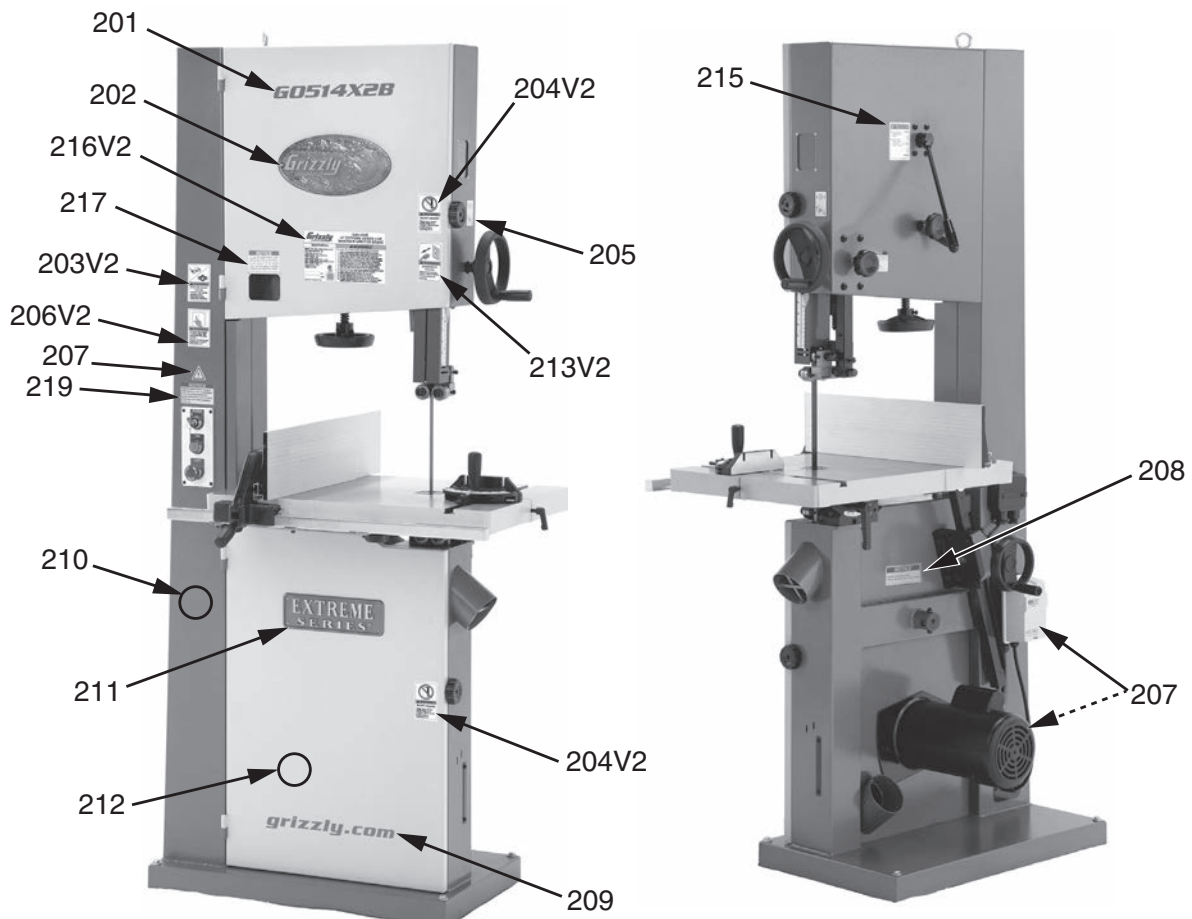

REF	PART #	DESCRIPTION
201	P0514X2B201	MODEL NUMBER LABEL
202	P0514X2B202	GRIZZLY LOGO PLATE
203V2	P0514X2B203V2	GLASSES/RESPIRATOR LABEL V2.08.13
204V2	P0514X2B204V2	OPEN DOOR LABEL V2.08.13
205	P0514X2B205	GUARD ADJ LABEL
206V2	P0514X2B206V2	READ MANUAL LABEL V2.08.13
207	P0514X2B207	ELECTRICITY LABEL
208	P0514X2B208	TABLE LOCK LEVER LABEL

REF	PART #	DESCRIPTION
210	P0514X2B210	TOUCH-UP PAINT, GRIZZLY GREEN
211	P0514X2B211	EXTREME SERIES NAMEPLATE
212	P0514X2B212	TOUCH-UP PAINT, PUTTY
213V2	P0514X2B213V2	DISCONNECT POWER LABEL V2.08.13
215	P0514X2B215	TENSION ADJ LABEL
216V2	P0514X2B216V2	MACHINE ID LABEL V2.02.12
217	P0514X2B217	BLADE TENSION LABEL
219	P0514X2B219	MAGNETIC BRAKE NOTICE

WARNING

Safety labels warn about machine hazards and ways to prevent injury. The owner of this machine **MUST** maintain the original location and readability of the labels on the machine. If any label is removed or becomes unreadable, **REPLACE** that label before using the machine again. Contact Grizzly at (800) 523-4777 or www.grizzly.com to order new labels.



WARRANTY & RETURNS

Grizzly Industrial, Inc. warrants every product it sells for a period of **1 year** to the original purchaser from the date of purchase. This warranty does not apply to defects due directly or indirectly to misuse, abuse, negligence, accidents, repairs or alterations or lack of maintenance. This is Grizzly's sole written warranty and any and all warranties that may be implied by law, including any merchantability or fitness, for any particular purpose, are hereby limited to the duration of this written warranty. We do not warrant or represent that the merchandise complies with the provisions of any law or acts unless the manufacturer so warrants. In no event shall Grizzly's liability under this warranty exceed the purchase price paid for the product and any legal actions brought against Grizzly shall be tried in the State of Washington, County of Whatcom.

We shall in no event be liable for death, injuries to persons or property or for incidental, contingent, special, or consequential damages arising from the use of our products.

The manufacturers reserve the right to change specifications at any time because they constantly strive to achieve better quality equipment. We make every effort to ensure that our products meet high quality and durability standards and we hope you never need to use this warranty.

In the event you need to use this warranty, contact us by mail or phone and give us all the details. We will then issue you a "Return Number," which must be clearly posted on the outside as well as the inside of the carton. We will not accept any item back without this number. Proof of purchase must accompany the merchandise.

Please feel free to write or call us if you have any questions about the machine or the manual.

Thank you again for your business and continued support. We hope to serve you again soon.

To take advantage of this warranty, you must register it at <https://www.grizzly.com/forms/warranty>, or you can scan the QR code below to be automatically directed to our warranty registration page. Enter all applicable information for the product.



grizzly.com[®]
TOOL WEBSITE

Buy Direct and Save with Grizzly[®] – Trusted, Proven and a Great Value!
~Since 1983~

*Visit Our Website Today For
Current Specials!*

**ORDER
24 HOURS A DAY!
1-800-523-4777**

